

ROUGHNESS

3.2

Rev.No.: 1 Alteration: Designation was changed

Date: 23/06/09 Name:cm_kwak

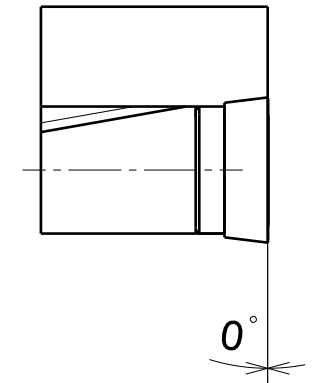
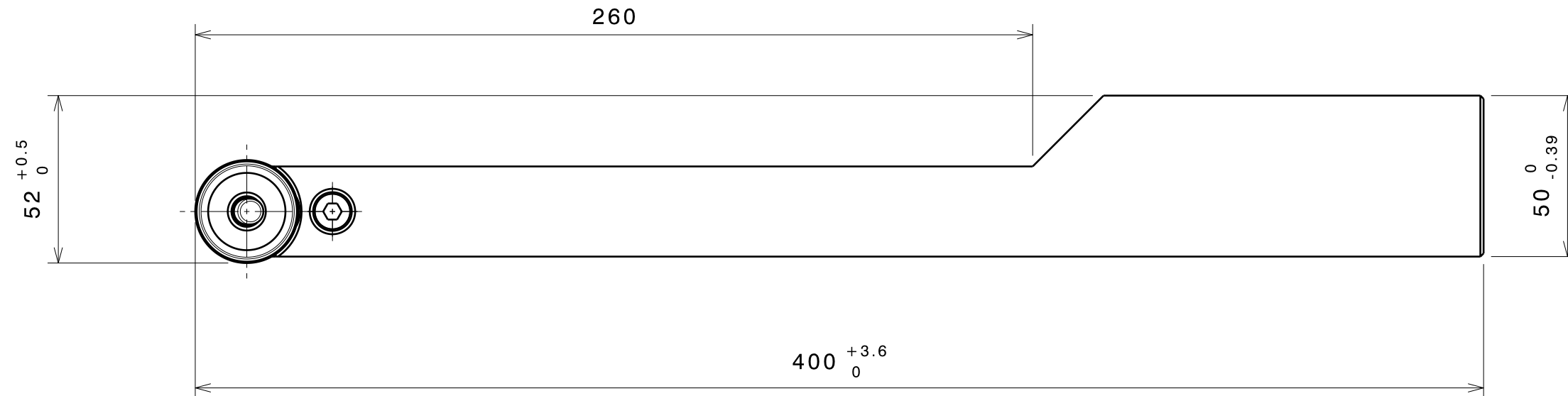
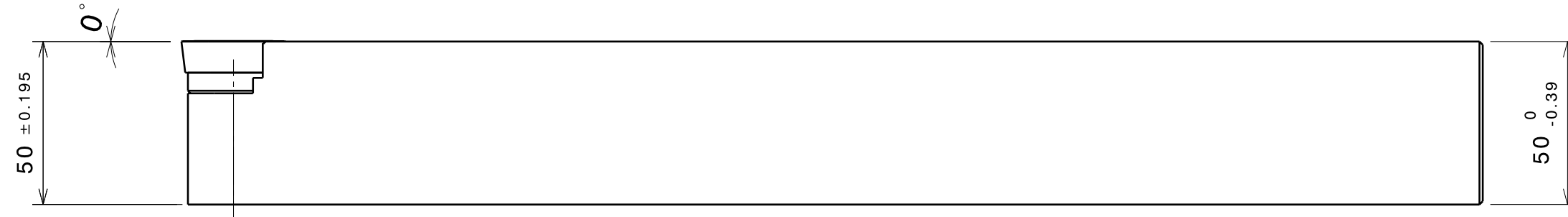

REMARK

1.V.J:0° F.A:0°

APPROVAL

PLEASE APPROVE THIS DRAWING.
PRODUCTION WILL BEGIN UPON RECEIPT.

SIGNED BY :
DATE :

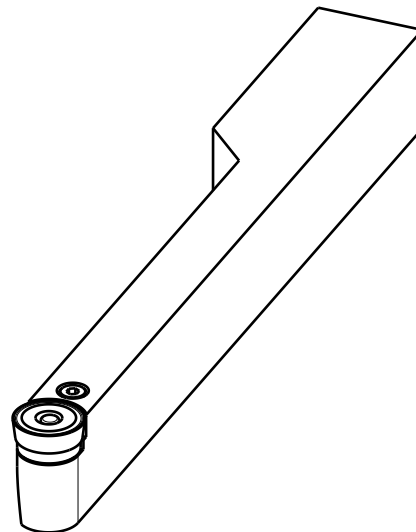

Isometric view
Scale: 3:10

7	WRENCH	1	L-W5
6	SHIM PINE	1	LSP 8
5	SHIM	1	LSR 3206
4	SCREW	1	LCS 8
3	LEVER	1	LCL 32C
2	INSERT	1	RCMX 320900
1	BODY

No.	Item / Designation	Qty.	Dwg/Cat.no.	Material	Dimensions	Notes
Unspecified Tolerances	Draw	Name	Date	Customer: TAEGUTEC LTD. Russia		
Dim.s:	Design	cm_kwak	22/06/09	Designation: PRDCR 5050 V32-RU		
Angles:	Check	dw_bae	22/06/09	Description: Turning Tool		Quotation
	Appr.	sh_lee	22/06/09			Page 1 Of 1
	Scale:	3:5		75247641		Rev. No. 1 Reg.No. 8901087

Copyright © this Drawing & Design is Confidential Property of TaeguTec Ltd. Taegu Korea and no part of it may be reproduced or conveyed otherwise without documented consent of TaeguTec Ltd.