

ОБРАБОТКА ОТВЕРСТИЙ



ОБРАБОТКА ОТВЕРСТИЙ

INDUSTRY 4.0



содержание

Руководство по выбору инструмента	D4
Сплавы	D14
Серии свёрл	
TOP-DRILL	D16
T-DRILL	D32
DRILL-SFEED	D49
DRILL-RUSH	D51
Инструмент для обработки фасок	D61
MODU-R-DRILL	D62
SPADE-RUSH	D66
Инструмент для обработки фасок	D69
Монолитные свёрла H-DRILL	D71
T-CHAMFER	D87
TOP-CAP	D89
T-DEEP	D94
Сменные пластины и головки для свёрл	D145
Рекомендуемые условия резания (Сверление)	D180

Указатель изображений



➤ Наружная подача СОЖ



➤ Внутренняя подача СОЖ



➤ Сквозное отверстие



➤ Глухое отверстие



➤ Трубы

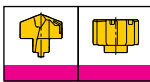

➤ Сменные головки



➤ Направляющие пластины



➤ Картриджи

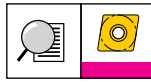

➤ Режущие пластины

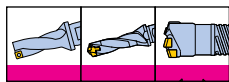

➤ Корпуса сверл и головки для глубокого сверления



➤ Комплектующие



➤ Техническое руководство



➤ Условия резания



Инструмент для развёртывания

TS-REAM

D213

TM-REAM

D215

TB-REAM

D217

Сменные головки и лезвия для развёртывания

D220

Рекомендуемые условия резания (Развёртывание)

D223

Технические данные

D230

Бланк заказа специального инструмента

D238

Руководство по выбору инструмента

Сверление

Серия		Сверло со сменными пластинами				
		TOPDRILL		TDRILL		TDEEP
		TOP 2/3/4/5	TOP-CA	TDR 2/3/4/5	TDR-CA	TRGD
						
Страницы		D16 - D27	D28 - D31	D32 - D44	D45 - D47	D139 - D144
Дс(мм)		Ø12.0 - Ø50.0	Ø51.0 - Ø80.0	Ø12.5 - Ø50.0	Ø51.0 - Ø80.0	Ø14.0 - Ø36.0
Глубина сверления (L/D)		2, 3, 4, 5 x Dc	2, 3, 4 x Dc	2, 3, 4, 5 x Dc	2.5, 3.5 x Dc	10-25 x Dc
Допуск отверстия		IT 11-13	IT 12-13	IT 12-13	IT 12-13	IT 10-11
Применение	Общее сверление		●	●	●	●
	Сверление пересеченных отверстий		●	●	●	○
	Сверление на наклонных поверхностях		○	○	○	○
	Прерывистое сверление		○	○	○	○
	Обработка фаски					
Подача СОЖ		Внутренняя	Внутренняя	Внутренняя	Внутренняя	Внутренняя

Руководство по выбору инструмента











Сверление

Сверло со сменными головками					Монолитное твердосплавное сверло
<i>DRILLSPEED</i>	<i>DRILLRUSH</i>		<i>MODURDRILL</i>	<i>SPADE RUSH</i>	<i>SOLID3DRILL</i>
3ED	TCD	TCD-M	TNDH-TP/MDB	LCD	3HD
					
D49 - D50	D51 - D59	D60	D62 - D65	D66 - D68	D69 - D70
Ø16.0 - Ø20.9	Ø6.0 - Ø25.9	M8 - M24 (ISO)	Ø26.0 - Ø50.0	Ø20.0 - Ø41.0	Ø4.0 - Ø12.0
3, 5 x Dc	1.5, 3, 5, 8, 12 x Dc		3, 5 x Dc	3, 5, 8 x Dc	3, 5 x Dc
IT 9-10	IT 9-10	IT 9-10	IT 10-12	IT 9-10	IT 8-10
●	●	●	●	●	●
○	●		●	●	●
		●			
Внутренняя	Внутренняя	Внутренняя	Внутренняя	Внутренняя	Внутренняя

● Рекомендуется, ○ Подходит

Руководство по выбору инструмента

Сверление

Серия		Монолитное твердосплавное сверло				Многофункциональный инструмент
		<i>HDRILL</i>				<i>TOPCAP</i>
		NHD-PE/PI	SHO 10/15/20	SHO-M	CDF	TCAP
						
Страницы		D71 - D82	D84	D85	D86	D89 - D93
Дс(мм)		Ø3.0 - Ø12.0	Ø4.0 - Ø10.0	M4 - M10 (ISO)	Ø3.0 - Ø12.7	Ø8.0 - Ø32.0
Глубина сверления (L/D)		3, 5 x Dc	10, 15, 20 x Dc			2.25, 3 x Dc
Допуск отверстия		IT 8-10	IT 8-10	IT 8-10	IT 8-10	IT 10-12
Применение	Общее сверление		●	●	●	●
	Сверление пересеченных отверстий		●	○		
	Сверление на наклонных поверхностях					●
	Прерывистое сверление					
	Обработка фаски				●	
Подача СОЖ		Наружная / Внутренняя	Внутренняя	Внутренняя	Наружная	Внутренняя

● Рекомендуется, ○ Подходит

Руководство по выбору инструмента

Глубокое сверление

Серия		Головка со сменными пластинами для глубокого сверления				
		TDEEP				
		TBTA3	TBTA5	TBTA7	TBTA9	TBTA-FB
Страницы		D95 - D100	D101 - D104	D105 - D107	D108 - D110	D111 - D115
Дс(мм)		Ø38.00 - Ø106.99	Ø107.00 - Ø168.99	Ø169.00 - Ø232.99	Ø233.00 - Ø291.99	Ø25.00 - Ø65.00
Глубина сверления (L/D)		100 x Dc	100 x Dc	100 x Dc	100 x Dc	100 x Dc
Допуск отверстия		IT 10	IT 10	IT 10	IT 10	IT 10
Шероховатость поверхности		3µm	3µm	3µm	3µm	3µm
Однотрубная система	Наружная четырехзаходная резьба	●	●	●	●	●
	Внутренняя однозаходная резьба	●	●	●★	●	●
Двухтрубная система	Наружная четырехзаходная резьба	●	●			●

★ В случае внутренней однозаходной резьбы серия TBTA7 охватывает диапазон до 245,99мм











Серия		Головка со сменными пластинами для глубокого сверления		Напайная головка для глубокого сверления	
		TDEEP			
		TBTA-TR	TBTA-R	BTA-SE/DE	BTS-SE
Страницы		D122 - D125	D116 - D121	D126 - D128	D129
Дс(мм)		Ø16.00 - Ø28.00	Ø25.00 - Ø110.99	Ø12.60 - Ø65.00	Ø8.00 - Ø20.00
Глубина сверления (L/D)		100 x Dc	100 x Dc	100 x Dc	100 x Dc
Допуск отверстия		IT 10	IT 7 - IT 9	IT 9	IT 9
Шероховатость поверхности		3µm	1-2µm	2µm	2µm
Однотрубная система	Наружная четырехзаходная резьба	●	●	●	●★
	Внутренняя однозаходная резьба	●	●		
Двухтрубная система	Наружная четырехзаходная резьба	●		●	

★ Двухзаходная резьба: Диаметр от 12,60 до 15,99мм

● Рекомендуется

Руководство по выбору инструмента

Развёртывание

Серия			Монолитная развёртка	Развёртка с механическим креплением		
			<i>TSREAM</i>	<i>TMREAM</i>	<i>TBREAM</i>	
			TS	TM	TB	
						
Страницы			D213 - D214	D215 - D216	D217 - D219	
Дс(мм)			Ø3.000 - Ø12.000	Ø11.501 - Ø32.000	Ø8.000 - Ø32.000	
Глубина сверления (L/D)			7.5-10 x Dc	3, 5, 8 x Dc	5-9 x Dc	
Допуск отверстия			IT 7	IT 7 ★	IT 6 ★★	
Применение		Сквозные отверстия	Глухие отверстия			
	Общее развёртывание			●	●	●
	Развёртывание пересеченных отверстий			●		●
	Развёртывание на наклонных поверхностях			●		●
	Прерывистое развёртывание			●	●	●
Подача СОЖ			Внутренняя	Внутренняя	Внутренняя	







★ Допуск до IT 6

★★ Допуск до IT 5

● Рекомендуется

Руководство по выбору инструмента











Пластины для свёрл

		TOPDRILL	TDRILL	DRILLSPEED	DRILLRUSH	
		SOMT	SPMG	3ED-P+	TCD-P/M/K/N	TCD-P+
Серия						
Страницы		D146 - D147	D148 - D149	D149	D150 - D156	D157 - D158
Размер		04/05/06/07/08 09/11/13/15	05/06/07/09 11/12/14	Ø16.0 - Ø20.5	Ø6.0 - Ø25.9	Ø6.0 - Ø25.9
Стружколом		DP, DK, DL, DA	DG, DK, DA	P+	P/M/K/N	P+
Сплавы		TT9080, TT9300 TT8020, TT6080 K10	TT9030, TT8020 TT7400, TT6030 K10	TT5130	TT9080 UF10	TT9080
Применение	Общее сверление		●	●	●	●
	Сверление пересеченных отверстий		●	●	●	●
	Сверление на наклонных поверхностях		○	○	○	○
	Прерывистое сверление		○	○		
	Обработка фаски					

● Рекомендуется, ○ Подходит

Руководство по выбору инструмента

Пластины для свёрл

			DRILLRUSH			MODURDRILL	
			TCD-F	TCD-P2	AOMT	TCD-P-CO+	SPGX...DW
Серия							
Страницы			D159 - D160	D161	D162	D163	D163
Размер			Ø8.0 - Ø25.5	Ø8.0 - Ø19.5	06 - C45	Ø15.9 - Ø25.9	06/07/09/11/14
Стружкойлом			F	P2	-	P-CO+	DW
Сплавы			TT9080	TT9080	TT9080	TT9080	TT9080
Применение	Общее сверление		●	●		●	●
	Сверление пересеченных отверстий		●	●		●	●
	Сверление на наклонных поверхностях		○	○		○	○
	Прерывистое сверление						
	Обработка фаски				●		

Руководство по выбору инструмента









Пластины для свёрл

<i>SPADE</i> RUSH		<i>DRILL</i> RUSH	<i>T</i> CHAMFER	<i>TOP</i> CAP
LCD-P	LCD-F	CRNG	XCGT	XCGT XCMT
				
D164 - D165	D165 - D166	D162	D167	D168 - D169
Ø20.0 - Ø41.0	Ø20.0 - Ø41.0	08 - 45CD	06/09	04/05/06/07/08 10/13/17
P	F		C30/C45/C60	TA/GV/TC
TT9080	TT9080	TT9080	TT9050	TT9080, TT8020, TT9030, K10
●				●
●				
○				
	●		●	

● Рекомендуется, ○ Подходит











Руководство по выбору инструмента

Пластины для свёрл

			<i>TDEEP</i>			
			NPHT NPMT	NPMX TPMX	TOGT	TPMX XPMT
Серия						
Страницы			D170 - D171	D172	D173	D174
Размер			05/06/07/08/09 /11/12/13	08/14/17/24/28	07/08/09/10/11/12	14/16/17/24
Стружколом			RG/LG	RB/RG	RS/GF	LG/-45
Сплавы			TT9030, TT6020, TT8125	TT9030, TT8125, TT7400, TT9300, TT7100, TT3500	TT9030	TT9030
Применение	Общее сверление		●	●	●	●
	Сверление пересеченных отверстий		○	○		○
	Сверление на наклонных поверхностях					
	Прерывистое сверление					
	Обработка фаски					

Руководство по выбору инструмента

Сменные головки и лезвия для развёрток

			<i>TM</i> REAM	<i>TB</i> REAM	
Серия			TM 	TB 	
Страницы			D220 - D221	D222	
Размер			Ø11.501 - Ø32.000	1/2/3/4	
Стружколом			BL/AS	A06/B06/B12	
Сплавы			TT9030	TT5030, TT5050	
Применение		Сквозные отверстия	Глухие отверстия		
	Общее развёртывание			●	●
	Развёртывание пересеченных отверстий				
	Развёртывание на наклонных поверхностях				
	Прерывистое развёртывание				

● Рекомендуется, ○ Подходит

Сплавы

Сверление

Сплавы	ISO	Характеристики и применение
TT6080 Покрытие PVD	K05 – K25 H05 – H25	<ul style="list-style-type: none"> Общая обработка серого и высокопрочного чугуна Чистовая и получистовая обработка закалённых сталей
TT9300 Покрытие CVD	P10 – P25	<ul style="list-style-type: none"> Высокоскоростная обработка углеродистых и легированных сталей
TT5130 Покрытие PVD	P20 – P40 K20 – K40	<ul style="list-style-type: none"> Сверление углеродистых и легированных сталей на высоких скоростях
TT9080 Покрытие PVD	P20 – P40 M20 – M40 S20 – S40	<ul style="list-style-type: none"> Общая обработка стали Общая обработка нержавеющей стали Общая обработка жаропрочных сплавов
TT9030 Покрытие PVD	P20 – P40 M20 – M40 S20 – S40	<ul style="list-style-type: none"> Общая обработка стали Общая обработка нержавеющей стали Общая обработка жаропрочных сплавов
TT8020 Покрытие PVD	P30 – P50 M30 – M50 S30 – S50	<ul style="list-style-type: none"> Прерывистая и черновая обработка стали Прерывистая и черновая обработка нержавеющей стали Обработка на низких скоростях и прерывистая обработка жаропрочных сплавов
K10 Твёрдый сплав без покрытия	K05 – K15 N05 – N15 S05 – S15	<ul style="list-style-type: none"> Общая обработка чугуна Общая обработка алюминиевых сплавов и цветных металлов Общая обработка жаропрочных сплавов
UF1A/UF10 Твёрдый сплав без покрытия	N10 – N25 S10 – S30	<ul style="list-style-type: none"> Общая обработка алюминиевых сплавов и цветных металлов Общая обработка жаропрочных сплавов

Руководство по выбору сплавов для обработки отверстий

Для стали

Скорость резания

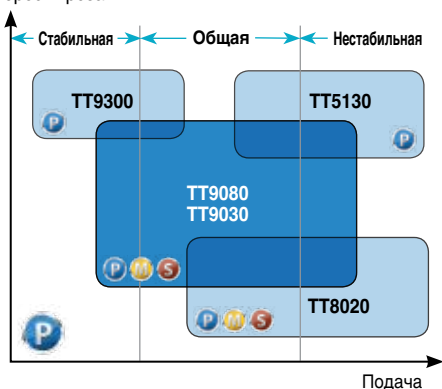

Для чугуна

Скорость резания

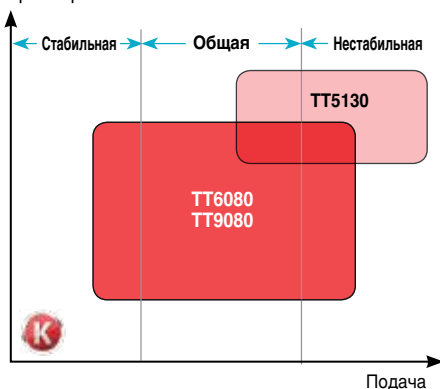

Корпуса свёрл



Сверло со сменными пластинами



• Глубина сверления: 2xD

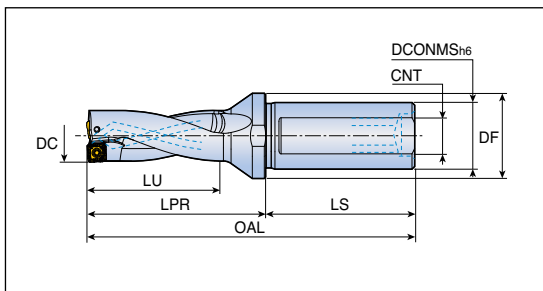

Обозначение	Размеры (мм)							Пластина
	DC	DCONMS	DF	LU	LPR	LS	CNT	
TOP 2120-20T2-04	12.0	20	25	24	44	50	M13X1.0	SOMT 04...DP
2125-20T2-04	12.5	20	25	26	46	50	M13X1.0	D146
2130-20T2-04	13.0	20	25	26	46	50	M13X1.0	
2135-20T2-04	13.5	20	25	28	46	50	M13X1.0	
2140-20T2-05	14.0	20	25	28	46	50	M13X1.0	SOMT 05...DP/DL/DK/DA
2145-20T2-05	14.5	20	25	30	49	50	M13X1.0	D146-147
2150-20T2-05	15.0	20	25	30	49	50	M13X1.0	
2155-20T2-05	15.5	20	25	32	52	50	M13X1.0	
2160-20T2-05	16.0	20	25	32	52	50	M13X1.0	
2165-25T2-06	16.5	25	32	34	54	56	M16X1.5	SOMT 06...DP/DL/DK/DA
2170-25T2-06	17.0	25	32	34	54	56	M16X1.5	D146-147
2175-25T2-06	17.5	25	32	36	57	56	M16X1.5	
2180-25T2-06	18.0	25	32	36	57	56	M16X1.5	
2185-25T2-06	18.5	25	32	38	59	56	M16X1.5	
2190-25T2-06	19.0	25	32	38	59	56	M16X1.5	
2195-25T2-07	19.5	25	32	40	63	56	M16X1.5	SOMT 07...DP/DL/DK/DA
2200-25T2-07	20.0	25	32	40	63	56	M16X1.5	D146-147
2205-25T2-07	20.5	25	32	42	65	56	M16X1.5	
2210-25T2-07	21.0	25	32	42	65	56	M16X1.5	
2215-25T2-07	21.5	25	32	44	67	56	M16X1.5	
2220-25T2-07	22.0	25	32	44	67	56	M16X1.5	
2225-25T2-08	22.5	25	32	46	68	56	M16X1.5	SOMT 08...DP/DL/DK/DA
2230-25T2-08	23.0	25	32	46	68	56	M16X1.5	D146-147
2230-32T2-08	23.0	32	40	46	68	60	M22X2.0	
2235-25T2-08	23.5	25	32	48	70	56	M16X1.5	
2235-32T2-08	23.5	32	40	48	70	60	M22X2.0	
2240-25T2-08	24.0	25	32	48	70	56	M16X1.5	
2240-32T2-08	24.0	32	40	48	70	60	M22X2.0	
2245-25T2-08	24.5	25	32	50	72	56	M16X1.5	
2245-32T2-08	24.5	32	40	50	72	60	M22X2.0	
2250-25T2-08	25.0	25	32	50	72	56	M16X1.5	
2250-32T2-08	25.0	32	40	50	72	60	M22X2.0	
2255-25T2-08	25.5	25	32	52	73	56	M16X1.5	
2255-32T2-08	25.5	32	40	52	73	60	M22X2.0	
2260-25T2-08	26.0	25	32	52	73	56	M16X1.5	
2260-32T2-08	26.0	32	40	52	73	60	M22X2.0	

• OAL = LPR + LS



Сверло со сменными пластинами

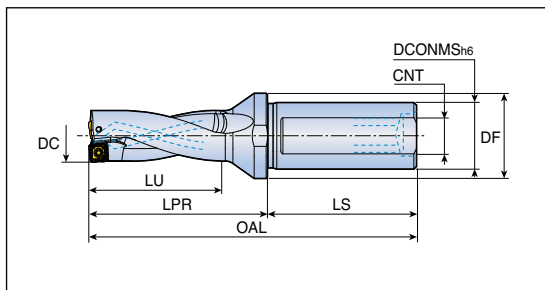

• Глубина сверления: 2xD



Обозначение	Размеры (мм)							Пластина
	DC	DCONMS	DF	LU	LPR	LS	CNT	
TOP 2265-32T2-09	26.5	32	40	54	77	60	M22X2.0	SOMT 09...DP/DL/DK/DA D146-147
2270-25T2-09	27.0	25	40	54	77	56	M16X1.5	
2270-32T2-09	27.0	32	40	54	77	60	M22X2.0	
2275-32T2-09	27.5	32	40	56	79	60	M22X2.0	
2280-25T2-09	28.0	25	40	56	79	56	M16X1.5	
2280-32T2-09	28.0	32	40	56	79	60	M22X2.0	
2285-32T2-09	28.5	32	40	58	81	60	M22X2.0	
2290-25T2-09	29.0	25	40	58	81	56	M16X1.5	
2290-32T2-09	29.0	32	40	58	81	60	M22X2.0	
2295-32T2-09	29.5	32	40	60	83	60	M22X2.0	
2300-32T2-09	30.0	32	40	60	83	60	M22X2.0	
2305-32T2-09	30.5	32	40	62	85	60	M22X2.0	
2310-32T2-09	31.0	32	40	62	85	60	M22X2.0	SOMT 11...DP/DL/DK/DA D146-147
2320-32T2-11	32.0	32	40	64	87	60	M22X2.0	
2320-40T2-11	32.0	40	50	64	87	70	M30X2.0	
2330-32T2-11	33.0	32	40	66	89	60	M22X2.0	
2330-40T2-11	33.0	40	50	66	89	70	M30X2.0	
2340-32T2-11	34.0	32	40	68	91	60	M22X2.0	
2340-40T2-11	34.0	40	50	68	91	70	M30X2.0	
2350-32T2-11	35.0	32	40	70	93	60	M22X2.0	
2350-40T2-11	35.0	40	50	70	93	70	M30X2.0	
2360-32T2-11	36.0	32	40	72	95	60	M22X2.0	
2360-40T2-11	36.0	40	50	72	95	70	M30X2.0	
2370-32T2-13	37.0	32	50	74	102	60	M22X2.0	
2370-40T2-13	37.0	40	50	74	102	70	M30X2.0	
2380-32T2-13	38.0	32	50	76	104	60	M22X2.0	
2380-40T2-13	38.0	40	50	76	104	70	M30X2.0	
2390-32T2-13	39.0	32	50	78	106	60	M22X2.0	
2390-40T2-13	39.0	40	50	78	106	70	M30X2.0	
2400-32T2-13	40.0	32	50	80	108	60	M22X2.0	
2400-40T2-13	40.0	40	50	80	108	70	M30X2.0	
2410-40T2-13	41.0	40	50	82	110	70	M30X2.0	
2420-40T2-13	42.0	40	50	84	112	70	M30X2.0	
2430-40T2-13	43.0	40	50	86	114	70	M30X2.0	

• OAL = LPR+LS



TOP 2...-T2

TOPDRILL

Сверло со сменными пластинами



• Глубина сверления: 2xD

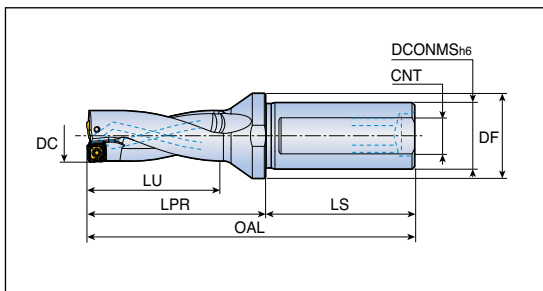

Обозначение	Размеры (мм)							Пластина
	DC	DCONMS	DF	LU	LPR	LS	CNT	
TOP 2440-40T2-15	44.0	40	60	88	123	70	M30X2.0	SOMT 15...DP/DL/DK/DA D146-147
2450-40T2-15	45.0	40	60	90	125	70	M30X2.0	
2460-40T2-15	46.0	40	60	92	127	70	M30X2.0	
2470-40T2-15	47.0	40	60	94	129	70	M30X2.0	
2480-40T2-15	48.0	40	60	96	131	70	M30X2.0	
2490-40T2-15	49.0	40	60	98	133	70	M30X2.0	
2500-40T2-15	50.0	40	60	100	135	70	M30X2.0	

• OAL = LPR+LS

Комплектующие

Обозначение	Винт	Ключ	Заглушка*	
TOP 2120 - 2135	TS 180411/HG	TD 6P	SL 20M	
TOP 2140 - 2160	TS 200431/HG-P	TD 6P	SL 20M	
TOP 2165 - 2220	TS 220521/HG-P	TD 7P	SL 25M	
TOP 2225 - 2260	SO 250651	TD 7	SL 25M / SL 32M	
TOP 2265 - 2360	TS 350881	TD 10	SL 25M / SL 32M / SL 40M	
TOP 2370 - 2430	TS 400931	TD 15	SL 32M / SL 40M	
TOP 2440 - 2550	TS 501151	TD 20	SL 40M	



• *Примечание: Заглушка для отверстия под СОЖ для токарного станка заказывается отдельно
 Пример заказа) Заглушка для хвостовика диаметром 25,0 мм: SL 25M

Сверло со сменными пластинами

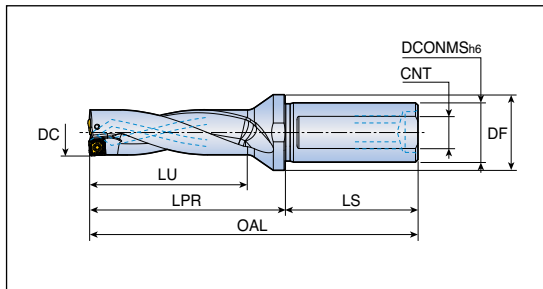

• Глубина сверления: 3xD



Обозначение	Размеры (мм)							Пластина
	DC	DCONMS	DF	LU	LPR	LS	CNT	
TOP 3120-20T2-04	12.0	20	25	36	56	50	M13X1.0	SOMT 04...DP
3125-20T2-04	12.5	20	25	39	59	50	M13X1.0	D146
3130-20T2-04	13.0	20	25	39	59	50	M13X1.0	
3135-20T2-04	13.5	20	25	42	60	50	M13X1.0	
3140-20T2-05	14.0	20	25	42	60	50	M13X1.0	SOMT 05...DP/DL/DK/DA
3145-20T2-05	14.5	20	25	45	64	50	M13X1.0	D146-147
3150-20T2-05	15.0	20	25	45	64	50	M13X1.0	
3155-20T2-05	15.5	20	25	48	68	50	M13X1.0	
3160-20T2-05	16.0	20	25	48	68	50	M13X1.0	
3165-25T2-06	16.5	25	32	51	71	56	M16X1.5	SOMT 06...DP/DL/DK/DA
3167-25T2-06 *	16.7	25	32	51	71	56	M16X1.5	D146-147
3170-25T2-06	17.0	25	32	51	71	56	M16X1.5	
3175-25T2-06	17.5	25	32	54	75	56	M16X1.5	
3180-25T2-06	18.0	25	32	54	75	56	M16X1.5	
3185-25T2-06	18.5	25	32	57	78	56	M16X1.5	
3190-25T2-06	19.0	25	32	57	78	56	M16X1.5	
3195-25T2-07	19.5	25	32	60	83	56	M16X1.5	SOMT 07...DP/DL/DK/DA
3200-25T2-07	20.0	25	32	60	83	56	M16X1.5	D146-147
3205-25T2-07	20.5	25	32	63	86	56	M16X1.5	
3210-25T2-07	21.0	25	32	63	86	56	M16X1.5	
3215-25T2-07	21.5	25	32	66	89	56	M16X1.5	
3220-25T2-07	22.0	25	32	66	89	56	M16X1.5	
3222-25T2-07 *	22.2	25	32	66	89	56	M16X1.5	
3225-25T2-08	22.5	25	32	69	91	56	M16X1.5	SOMT 08...DP/DL/DK/DA
3230-25T2-08	23.0	25	32	69	91	56	M16X1.5	D146-147
3230-32T2-08	23.0	32	40	69	91	60	M22X2.0	
3235-25T2-08	23.5	25	32	72	94	56	M16X1.5	
3235-32T2-08	23.5	32	40	72	94	60	M22X2.0	
3240-25T2-08	24.0	25	32	72	94	56	M16X1.5	
3240-32T2-08	24.0	32	40	72	94	60	M22X2.0	
3245-25T2-08	24.5	25	32	75	97	56	M16X1.5	
3245-32T2-08	24.5	32	40	75	97	60	M22X2.0	
3250-25T2-08	25.0	25	32	75	97	56	M16X1.5	
3250-32T2-08	25.0	32	40	75	97	60	M22X2.0	
3254-25T2-08 *	25.4	25	32	75	97	56	M16X1.5	



- *! Сверла предназначены для дюймовых отверстий
- OAL = LPR+LS

Сверло со сменными пластинами



• Глубина сверления: 3xD

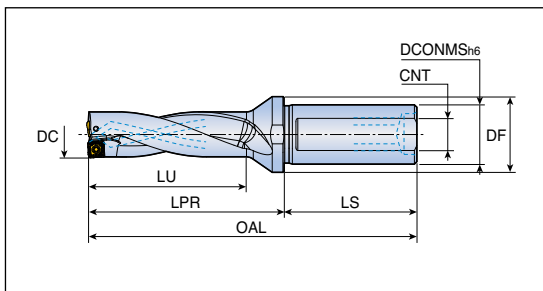

Обозначение	Размеры (мм)							Пластина
	DC	DCONMS	DF	LU	LPR	LS	CNT	
TOP 3255-25T2-08	25.5	25	32	78	99	56	M16X1.5	SOMT 08...DP/DL/DK/DA
3255-32T2-08	25.5	32	40	78	99	60	M22X2.0	D146-147
3260-25T2-08	26.0	25	32	78	99	56	M16X1.5	
3260-32T2-08	26.0	32	32	78	99	60	M22X2.0	
3265-25T2-09	26.5	25	40	81	104	56	M16X1.5	SOMT 09...DP/DL/DK/DA
3265-32T2-09	26.5	32	40	81	104	60	M22X2.0	D146-147
3270-25T2-09	27.0	25	40	81	104	56	M16X1.5	
3270-32T2-09	27.0	32	40	81	104	60	M22X2.0	
3275-25T2-09	27.5	25	40	84	107	56	M16X1.5	
3275-32T2-09	27.5	32	40	84	107	60	M22X2.0	
3280-25T2-09	28.0	25	40	84	107	56	M16X1.5	
3280-32T2-09	28.0	32	40	84	107	60	M22X2.0	
3285-25T2-09	28.5	25	40	87	110	56	M16X1.5	
3285-32T2-09	28.5	32	40	87	110	60	M22X2.0	
3290-25T2-09	29.0	25	40	87	110	56	M16X1.5	
3290-32T2-09	29.0	32	40	87	110	60	M22X2.0	
3295-32T2-09	29.5	32	40	90	113	60	M22X2.0	
3300-32T2-09	30.0	32	40	90	113	60	M22X2.0	
3305-32T2-09	30.5	32	40	93	116	60	M22X2.0	
3310-32T2-09	31.0	32	40	93	116	60	M22X2.0	
3320-32T2-11	32.0	32	40	96	119	60	M22X2.0	SOMT 11...DP/DL/DK/DA
3320-40T2-11	32.0	40	50	96	119	70	M30X2.0	D146-147
3330-32T2-11	33.0	32	40	99	122	60	M22X2.0	
3330-40T2-11	33.0	40	50	99	122	70	M30X2.0	
3340-32T2-11	34.0	32	40	102	125	60	M22X2.0	
3340-40T2-11	34.0	40	50	102	125	70	M30X2.0	
3350-32T2-11	35.0	32	40	105	128	60	M22X2.0	
3350-40T2-11	35.0	40	50	105	128	70	M30X2.0	
3360-32T2-11	36.0	32	40	108	131	60	M22X2.0	
3360-40T2-11	36.0	40	50	108	131	70	M30X2.0	
3370-32T2-13	37.0	32	50	111	139	60	M22X2.0	SOMT 13...DP/DL/DK/DA
3370-40T2-13	37.0	40	50	111	139	70	M30X2.0	D146-147
3380-32T2-13	38.0	32	50	114	142	60	M22X2.0	
3380-40T2-13	38.0	40	50	114	142	70	M30X2.0	
3390-32T2-13	39.0	32	50	117	145	60	M22X2.0	



• OAL = LPR + LS

Сверло со сменными пластинами

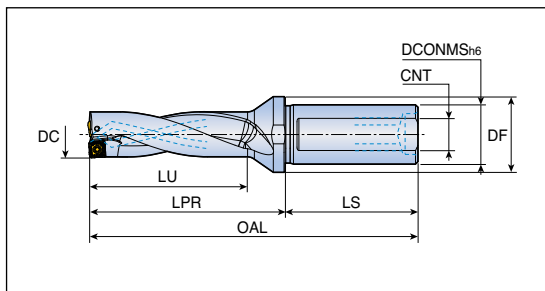

• Глубина сверления: 3xD



Обозначение	Размеры (мм)							Пластина
	DC	DCONMS	DF	LU	LPR	LS	CNT	
TOP 3390-40T2-13	39.0	40	50	117	145	70	M30X2.0	SOMT 13...DP/DL/DK/DA D146-147
3400-32T2-13	40.0	32	50	120	148	60	M22X2.0	
3400-40T2-13	40.0	40	50	120	148	70	M30X2.0	
3410-40T2-13	41.0	40	50	123	151	70	M30X2.0	
3420-40T2-13	42.0	40	50	126	154	70	M30X2.0	
3430-40T2-13	43.0	40	50	129	157	70	M30X2.0	
3440-40T2-15	44.0	40	60	132	167	70	M30X2.0	SOMT 15...DP/DL/DK/DA D146-147
3450-40T2-15	45.0	40	60	135	170	70	M30X2.0	
3460-40T2-15	46.0	40	60	138	173	70	M30X2.0	
3470-40T2-15	47.0	40	60	141	176	70	M30X2.0	
3480-40T2-15	48.0	40	60	144	179	70	M30X2.0	
3490-40T2-15	49.0	40	60	147	182	70	M30X2.0	
3500-40T2-15	50.0	40	60	150	185	70	M30X2.0	

• OAL = LPR+LS

Комплектующие

Обозначение	Винт	Ключ	Заглушка*	
TOP 3120 - 3135	TS 18041/HG	TD 6P	SL 20M	
TOP 3140 - 3160	TS 200431/HG-P	TD 6P	SL 20M	
TOP 3165 - 3220	TS 220521/HG-P	TD 7P	SL 25M	
TOP 3225 - 3260	SO 250651	TD 7	SL 25M / SL 32M	
TOP 3265 - 3360	TS 350881	TD 10	SL 25M / SL 32M / SL 40M	
TOP 3370 - 3430	TS 400931	TD 15	SL 32M / SL 40M	
TOP 3440 - 3500	TS 501151	TD 20	SL 40M	



• *Примечание: Заглушка для отверстия под СОЖ для токарного станка заказывается отдельно
 Пример заказа) Заглушка для хвостовика диаметром 25,0 мм: SL 25M

Сверло со сменными пластинами



• Глубина сверления: 4xD

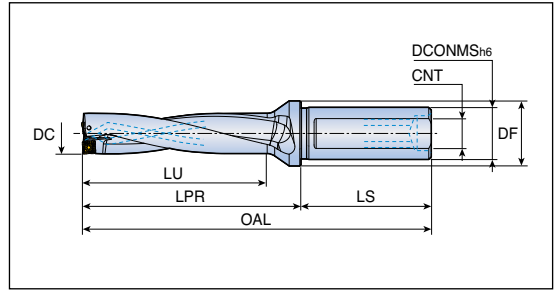

Обозначение	Размеры (мм)							Пластина
	DC	DCONMS	DF	LU	LPR	LS	CNT	
TOP 4120-20T2-04	12.0	20	25	48	68	50	M13X1.0	SOMT 04...DP
4125-20T2-04	12.5	20	25	52	72	50	M13X1.0	D146
4130-20T2-04	13.0	20	25	52	72	50	M13X1.0	
4135-20T2-04	13.5	20	25	56	74	50	M13X1.0	
4140-20T2-05	14.0	20	25	56	74	50	M13X1.0	SOMT 05...DP/DL/DK/DA
4145-20T2-05	14.5	20	25	60	79	50	M13X1.0	D146-147
4150-20T2-05	15.0	20	25	60	79	50	M13X1.0	
4155-20T2-05	15.5	20	25	64	84	50	M13X1.0	
4160-20T2-05	16.0	20	25	64	84	50	M13X1.0	
4165-25T2-06	16.5	25	32	68	88	56	M16X1.5	SOMT 06...DP/DL/DK/DA
4170-25T2-06	17.0	25	32	68	88	56	M16X1.5	D146-147
4175-25T2-06	17.5	25	32	72	93	56	M16X1.5	
4180-25T2-06	18.0	25	32	72	93	56	M16X1.5	
4185-25T2-06	18.5	25	32	76	97	56	M16X1.5	
4190-25T2-06	19.0	25	32	76	97	56	M16X1.5	
4195-25T2-07	19.5	25	32	80	103	56	M16X1.5	SOMT 07...DP/DL/DK/DA
4200-25T2-07	20.0	25	32	80	103	56	M16X1.5	D146-147
4205-25T2-07	20.5	25	32	84	107	56	M16X1.5	
4210-25T2-07	21.0	25	32	84	107	56	M16X1.5	
4215-25T2-07	21.5	25	32	88	111	56	M16X1.5	
4220-25T2-07	22.0	25	32	88	111	56	M16X1.5	
4225-25T2-08	22.5	25	32	92	114	56	M16X1.5	SOMT 08...DP/DL/DK/DA
4230-25T2-08	23.0	25	32	92	114	56	M16X1.5	D146-147
4230-32T2-08	23.0	32	40	92	114	60	M22X2.0	
4235-25T2-08	23.5	25	32	96	118	56	M16X1.5	
4235-32T2-08	23.5	32	40	96	118	60	M22X2.0	
4240-25T2-08	24.0	25	32	96	118	56	M16X1.5	
4240-32T2-08	24.0	32	40	96	118	60	M22X2.0	
4245-25T2-08	24.5	25	32	100	122	56	M16X1.5	
4245-32T2-08	24.5	32	40	100	122	60	M22X2.0	
4250-25T2-08	25.0	25	32	100	122	56	M16X1.5	
4250-32T2-08	25.0	32	40	100	122	60	M22X2.0	
4254-25T2-08 *	25.4	25	32	100	122	56	M16X1.5	
4255-25T2-08	25.5	25	32	104	125	56	M16X1.5	
4255-32T2-08	25.5	32	40	104	125	60	M22X2.0	



- *'1' Сверла предназначены для дюймовых отверстий
- OAL = LPR + LS

Сверло со сменными пластинами



• Глубина сверления: 4xD

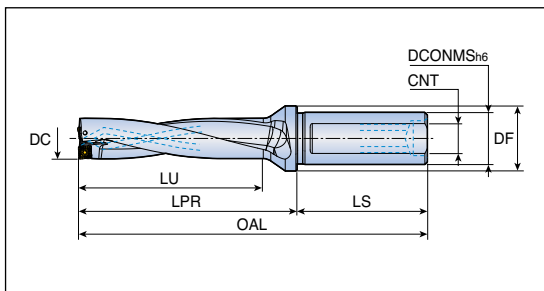

Обозначение	Размеры (мм)							Пластина
	DC	DCONMS	DF	LU	LPR	LS	CNT	
TOP 4260-25T2-08	26.0	25	32	104	125	56	M16X1.5	SOMT 08...DP/DL/DK/DA D146-147
4260-32T2-08	26.0	32	40	104	125	60	M22X2.0	
4265-25T2-09	26.5	25	40	108	131	56	M16X1.5	SOMT 09...DP/DL/DK/DA D146-147
4265-32T2-09	26.5	32	40	108	131	60	M22X2.0	
4270-25T2-09	27.0	25	40	108	131	56	M16X1.5	SOMT 11...DP/DL/DK/DA D146-147
4270-32T2-09	27.0	32	40	108	131	60	M22X2.0	
4275-25T2-09	27.5	25	40	112	135	56	M16X1.5	SOMT 13...DP/DL/DK/DA D146-147
4275-32T2-09	27.5	32	40	112	135	60	M22X2.0	
4280-25T2-09	28.0	25	40	112	135	56	M16X1.5	SOMT 13...DP/DL/DK/DA D146-147
4280-32T2-09	28.0	32	40	112	135	60	M22X2.0	
4285-25T2-09	28.5	25	40	116	139	56	M16X1.5	SOMT 13...DP/DL/DK/DA D146-147
4285-32T2-09	28.5	32	40	116	139	60	M22X2.0	
4286-32T2-09 *	28.6	32	40	116	139	60	M22X2.0	SOMT 13...DP/DL/DK/DA D146-147
4290-25T2-09	29.0	25	40	116	139	56	M16X1.5	
4290-32T2-09	29.0	32	40	116	139	60	M22X2.0	SOMT 13...DP/DL/DK/DA D146-147
4295-32T2-09	29.5	32	40	120	143	60	M22X2.0	
4300-32T2-09	30.0	32	40	120	143	60	M22X2.0	SOMT 13...DP/DL/DK/DA D146-147
4305-32T2-09	30.5	32	40	124	147	60	M22X2.0	
4310-32T2-09	31.0	32	40	124	147	60	M22X2.0	SOMT 13...DP/DL/DK/DA D146-147
4318-32T2-11 *	31.8	32	40	128	151	60	M22X2.0	
4320-32T2-11	32.0	32	40	128	151	60	M22X2.0	SOMT 13...DP/DL/DK/DA D146-147
4320-40T2-11	32.0	40	50	128	151	70	M30X2.0	
4330-32T2-11	33.0	32	40	132	155	60	M22X2.0	SOMT 13...DP/DL/DK/DA D146-147
4330-40T2-11	33.0	40	50	132	155	70	M30X2.0	
4340-32T2-11	34.0	32	40	136	159	60	M22X2.0	SOMT 13...DP/DL/DK/DA D146-147
4340-40T2-11	34.0	40	50	136	159	70	M30X2.0	
4349-40T2-11 *	34.9	40	50	140	163	70	M30X2.0	SOMT 13...DP/DL/DK/DA D146-147
4350-32T2-11	35.0	32	40	140	163	60	M22X2.0	
4350-40T2-11	35.0	40	50	140	163	70	M30X2.0	SOMT 13...DP/DL/DK/DA D146-147
4360-32T2-11	36.0	32	40	144	167	60	M22X2.0	
4360-40T2-11	36.0	40	50	144	167	70	M30X2.0	SOMT 13...DP/DL/DK/DA D146-147
4370-32T2-13	37.0	32	50	148	176	60	M22X2.0	
4370-40T2-13	37.0	40	50	148	176	70	M30X2.0	SOMT 13...DP/DL/DK/DA D146-147
4371-40T2-13 *	37.1	40	50	148	176	70	M30X2.0	



- *1* Сверла предназначены для дюймовых отверстий
- OAL = LPR+LS

Сверло со сменными пластинами



• Глубина сверления: 4xD

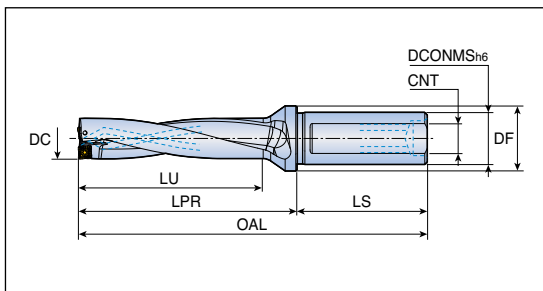

Обозначение	Размеры (мм)							Пластина	
	DC	DCONMS	DF	LU	LPR	LS	CNT		
TOP 4380-32T2-13	38.0	32	50	152	180	60	M22X2.0	SOMT 13...DP/DL/DK/DA D146-147	
4380-40T2-13	38.0	40	50	152	180	70	M30X2.0		
4381-40T2-13 *	38.1	40	50	152	180	70	M30X2.0		
4390-32T2-13	39.0	32	50	156	184	60	M22X2.0		
4390-40T2-13	39.0	40	50	156	184	70	M30X2.0		
4400-32T2-13	40.0	32	50	160	188	60	M22X2.0		
4400-40T2-13	40.0	40	50	160	188	70	M30X2.0		
4410-40T2-13	41.0	40	50	164	192	70	M30X2.0		
4413-40T2-13 *	41.3	40	50	164	192	70	M30X2.0		
4420-40T2-13	42.0	40	50	168	196	70	M30X2.0		
4429-40T2-13 *	42.9	40	50	172	200	70	M30X2.0		
4430-40T2-13	43.0	40	50	172	200	70	M30X2.0		
4440-40T2-15	44.0	40	60	176	211	70	M30X2.0		SOMT 15...DP/DL/DK/DA D146-147
4445-40T2-15 *	44.5	40	60	180	215	70	M30X2.0		
4450-40T2-15	45.0	40	60	180	215	70	M30X2.0		
4460-40T2-15	46.0	40	60	184	219	70	M30X2.0		
4470-40T2-15	47.0	40	60	188	223	70	M30X2.0		
4476-40T2-15 *	47.6	40	60	192	227	70	M30X2.0		
4480-40T2-15	48.0	40	60	192	227	70	M30X2.0		
4490-40T2-15	49.0	40	60	196	231	70	M30X2.0		
4500-40T2-15	50.0	40	60	200	235	70	M30X2.0		
4508-40T2-15 *	50.8	40	60	204	239	70	M30X2.0		

- *1* Сверла предназначены для дюймовых отверстий
- OAL = LPR+LS

Комплекующие

Обозначение	Винт	Ключ	Заглушка*	
TOP 4120 - 4135	TS 18041/HG	TD 6P	SL 20M	
TOP 4140 - 4160	TS 20043I/HG-P	TD 6P	SL 20M	
TOP 4165 - 4220	TS 22052I/HG-P	TD 7P	SL 25M	
TOP 4225 - 4260	SO 25065I	TD 7	SL 25M / SL 32M	
TOP 4265 - 4360	TS 35088I	TD 10	SL 25M / SL 32M / SL 40M	
TOP 4370 - 4430	TS 40093I	TD 15	SL 32M / SL 40M	
TOP 4440 - 4508	TS 50115I	TD 20	SL 40M	



- *Примечание: Заглушка для отверстия под СОЖ для токарного станка заказывается отдельно
(Пример заказа) Заглушка для хвостовика диаметром 25,0 мм: SL 25M

Сверло со сменными пластинами

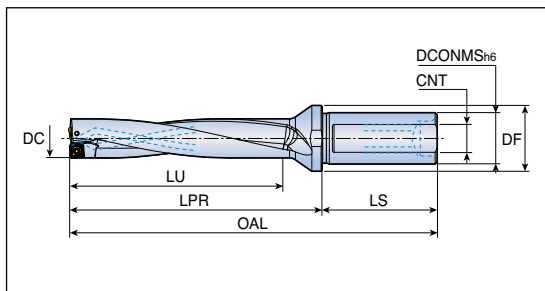

• Глубина сверления: 5xD



Обозначение	Размеры (мм)							Пластина
	DC	DCONMS	DF	LU	LPR	LS	CNT	
TOP 5120-20T2-04	12.0	20	25	60	80	50	M13X1.0	SOMT 04...DP
5125-20T2-04	12.5	20	25	65	85	50	M13X1.0	D146
5130-20T2-04	13.0	20	25	65	85	50	M13X1.0	
5135-20T2-04	13.5	20	25	70	88	50	M13X1.0	
5140-20T2-05	14.0	20	25	70	88	50	M13X1.0	SOMT 05...DP/DL/DK/DA
5145-20T2-05	14.5	20	25	75	94	50	M13X1.0	D146-147
5150-20T2-05	15.0	20	25	75	94	50	M13X1.0	
5155-20T2-05	15.5	20	25	80	100	50	M13X1.0	
5160-20T2-05	16.0	20	25	80	100	50	M13X1.0	
5165-25T2-06	16.5	25	32	85	105	56	M16X1.5	SOMT 06...DP/DL/DK/DA
5170-25T2-06	17.0	25	32	85	105	56	M16X1.5	D146-147
5175-25T2-06	17.5	25	32	90	111	56	M16X1.5	
5180-25T2-06	18.0	25	32	90	111	56	M16X1.5	
5185-25T2-06	18.5	25	32	95	116	56	M16X1.5	
5190-25T2-06	19.0	25	32	95	116	56	M16X1.5	
5195-25T2-07	19.5	25	32	100	123	56	M16X1.5	SOMT 07...DP/DL/DK/DA
5200-25T2-07	20.0	25	32	100	123	56	M16X1.5	D146-147
5205-25T2-07	20.5	25	32	105	128	56	M16X1.5	
5210-25T2-07	21.0	25	32	105	128	56	M16X1.5	
5215-25T2-07	21.5	25	32	110	133	56	M16X1.5	
5220-25T2-07	22.0	25	32	110	133	56	M16X1.5	
5222-25T2-07 *	22.2	25	32	110	133	56	M16X1.5	
5225-25T2-08	22.5	25	32	115	137	56	M16X1.5	SOMT 08...DP/DL/DK/DA
5230-25T2-08	23.0	25	32	115	137	56	M16X1.5	D146-147
5230-32T2-08	23.0	32	40	115	137	60	M22X2.0	
5235-25T2-08	23.5	25	32	120	142	56	M16X1.5	
5235-32T2-08	23.5	32	40	120	142	60	M22X2.0	
5240-25T2-08	24.0	25	32	120	142	56	M16X1.5	
5240-32T2-08	24.0	32	40	120	142	60	M22X2.0	
5245-25T2-08	24.5	25	32	125	147	56	M16X1.5	
5245-32T2-08	24.5	32	40	125	147	60	M22X2.0	
5250-25T2-08	25.0	25	32	125	147	56	M16X1.5	
5250-32T2-08	25.0	32	40	125	147	60	M22X2.0	
5255-25T2-08	25.5	25	32	130	151	56	M16X1.5	
5255-32T2-08	25.5	32	40	130	151	60	M22X2.0	



- *1* Сверла предназначены для дюймовых отверстий
- OAL = LPR+LS

Сверло со сменными пластинами



• Глубина сверления: 5xD

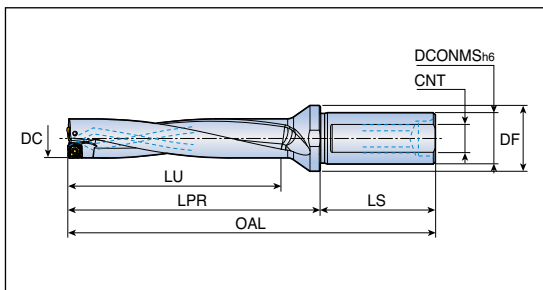

Обозначение	Размеры (мм)							Пластина
	DC	DCONMS	DF	LU	LPR	LS	CNT	
TOP 5260-25T2-08	26.0	25	32	130	151	56	M16X1.5	SOMT 08...DP/DL/DK/DA D146-147
5260-32T2-08	26.0	32	40	130	151	60	M22X2.0	
5265-32T2-09	26.5	32	40	135	158	60	M22X2.0	SOMT 09...DP/DL/DK/DA D146-147
5270-25T2-09	27.0	25	40	135	158	56	M16X1.5	
5270-32T2-09	27.0	32	40	135	158	60	M22X2.0	SOMT 09...DP/DL/DK/DA D146-147
5275-32T2-09	27.5	32	40	140	163	60	M22X2.0	
5280-25T2-09	28.0	25	40	140	163	56	M16X1.5	SOMT 09...DP/DL/DK/DA D146-147
5280-32T2-09	28.0	32	40	140	163	60	M22X2.0	
5282-32T2-09 *	28.2	32	40	140	163	60	M22X2.0	SOMT 09...DP/DL/DK/DA D146-147
5285-32T2-09	28.5	32	40	145	168	60	M22X2.0	
5290-25T2-09	29.0	25	40	145	168	56	M16X1.5	SOMT 09...DP/DL/DK/DA D146-147
5290-32T2-09	29.0	32	40	145	168	60	M22X2.0	
5295-32T2-09	29.5	32	40	150	173	60	M22X2.0	SOMT 09...DP/DL/DK/DA D146-147
5300-32T2-09	30.0	32	40	150	173	60	M22X2.0	
5305-32T2-09	30.5	32	40	155	178	60	M22X2.0	SOMT 09...DP/DL/DK/DA D146-147
5310-32T2-09	31.0	32	40	155	178	60	M22X2.0	
5320-32T2-11	32.0	32	40	160	183	60	M22X2.0	SOMT 11...DP/DL/DK/DA D146-147
5320-40T2-11	32.0	40	50	160	183	70	M30X2.0	
5330-32T2-11	33.0	32	40	165	188	60	M22X2.0	SOMT 11...DP/DL/DK/DA D146-147
5330-40T2-11	33.0	40	50	165	188	70	M30X2.0	
5340-32T2-11	34.0	32	40	170	193	60	M22X2.0	SOMT 11...DP/DL/DK/DA D146-147
5340-40T2-11	34.0	40	50	170	193	70	M30X2.0	
5350-32T2-11	35.0	32	40	175	198	60	M22X2.0	SOMT 11...DP/DL/DK/DA D146-147
5350-40T2-11	35.0	40	50	175	198	70	M30X2.0	
5360-32T2-11	36.0	32	40	180	203	60	M22X2.0	SOMT 11...DP/DL/DK/DA D146-147
5360-40T2-11	36.0	40	50	180	203	70	M30X2.0	
5370-32T2-13	37.0	32	50	185	213	60	M22X2.0	SOMT 13...DP/DL/DK/DA D146-147
5370-40T2-13	37.0	40	50	185	213	70	M30X2.0	
5380-32T2-13	38.0	32	50	190	218	60	M22X2.0	SOMT 13...DP/DL/DK/DA D146-147
5380-40T2-13	38.0	40	50	190	218	70	M30X2.0	
5390-32T2-13	39.0	32	50	195	223	60	M22X2.0	SOMT 13...DP/DL/DK/DA D146-147
5390-40T2-13	39.0	40	50	195	223	70	M30X2.0	
5400-32T2-13	40.0	32	50	200	228	60	M22X2.0	SOMT 13...DP/DL/DK/DA D146-147
5400-40T2-13	40.0	40	50	200	228	70	M30X2.0	



- '*1' Сверла предназначены для дюймовых отверстий
- OAL = LPR + LS

Сверло со сменными пластинами

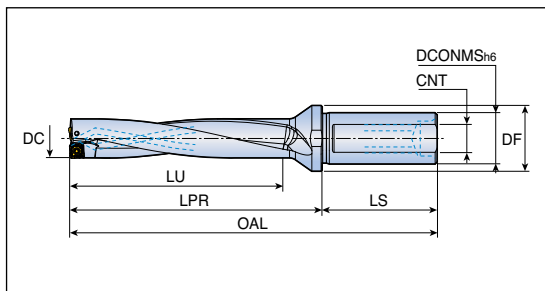

• Глубина сверления: 5xD



Обозначение	Размеры (мм)							Пластина
	DC	DCONMS	DF	LU	LPR	LS	CNT	
TOP 5410-40T2-13	41.0	40	50	205	233	70	M30X2.0	SOMT 13...DP/DL/DK/DA
5420-40T2-13	42.0	40	50	210	238	70	M30X2.0	D146-147
5430-40T2-13	43.0	40	50	215	243	70	M30X2.0	
5440-40T2-15	44.0	40	60	220	255	70	M30X2.0	SOMT 15...DP/DL/DK/DA
5450-40T2-15	45.0	40	60	225	260	70	M30X2.0	D146-147
5460-40T2-15	46.0	40	60	230	265	70	M30X2.0	
5470-40T2-15	47.0	40	60	235	270	70	M30X2.0	
5480-40T2-15	48.0	40	60	240	275	70	M30X2.0	
5490-40T2-15	49.0	40	60	245	280	70	M30X2.0	
5500-40T2-15	50.0	40	60	250	285	70	M30X2.0	

• OAL = LPR+LS

Комплектующие

Обозначение	Винт 	Ключ 	Заглушка* 	
TOP 5120 - 5135	TS 18041/HG	TD 6P	SL 20M	
TOP 5140 - 5160	TS 200431/HG-P	TD 6P	SL 20M	
TOP 5165 - 5220	TS 220521/HG-P	TD 7P	SL 25M	
TOP 5225 - 5260	SO 25065I	TD 7	SL 25M / SL 32M	
TOP 5265 - 5360	TS 35088I	TD 10	SL 25M / SL 32M / SL 40M	
TOP 5370 - 5430	TS 40093I	TD 15	SL 32M / SL 40M	
TOP 5440 - 5500	TS 50115I	TD 20	SL 40M	



• *Примечание: Заглушка для отверстия под СОЖ для токарного станка заказывается отдельно
 Пример заказа) Заглушка для хвостовика диаметром 25,0 мм: SL 25M

Сверло со сменными картриджами



• Глубина сверления: 2xD

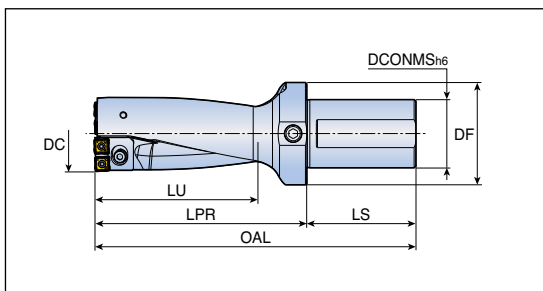

Обозначение	Размеры (мм)							Установочная пластина	Пластина
	DC	DCONMS	DF	OAL	LU	LPR	LS		
TOP 2051-55-50T2-09CA	51	50	75	223	110	143	80	-	SOMT 09... DP/DL/DK/DA
	52	50	75	223	110	143	80	TOP-0901	D146-147
	53	50	75	223	110	143	80	TOP-0902	
	54	50	75	223	110	143	80	TOP-0903	
	55	50	75	223	110	143	80	TOP-0904	
TOP 2056-60-50T2-11CA	56	50	75	236	120	156	80	-	
	57	50	75	236	120	156	80	TOP-0901	D146-147
	58	50	75	236	120	156	80	TOP-0902	
	59	50	75	236	120	156	80	TOP-0903	
	60	50	75	236	120	156	80	TOP-0904	
TOP 2061-65-50T2-11CA	61	50	75	249	130	169	80	-	
	62	50	75	249	130	169	80	TOP-0901	D146-147
	63	50	75	249	130	169	80	TOP-0902	
	64	50	75	249	130	169	80	TOP-0903	
	65	50	75	249	130	169	80	TOP-0904	
TOP 2066-70-50T2-11CA	66	50	75	262	140	182	80	-	
	67	50	75	262	140	182	80	TOP-0901	D146-147
	68	50	75	262	140	182	80	TOP-0902	
	69	50	75	262	140	182	80	TOP-0903	
	70	50	75	262	140	182	80	TOP-0904	
TOP 2071-75-50T2-13CA	71	50	75	275	150	195	80	-	
	72	50	75	275	150	195	80	TOP-0901	D146-147
	73	50	75	275	150	195	80	TOP-0902	
	74	50	75	275	150	195	80	TOP-0903	
	75	50	75	275	150	195	80	TOP-0904	
TOP 2076-80-50T2-13CA	76	50	75	288	160	208	80	-	
	77	50	75	288	160	208	80	TOP-0901	D146-147
	78	50	75	288	160	208	80	TOP-0902	
	79	50	75	288	160	208	80	TOP-0903	
	80	50	75	288	160	208	80	TOP-0904	



Сверло со сменными картриджами

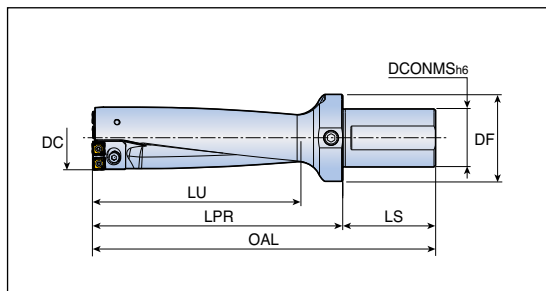

• Глубина сверления: 3xD



Обозначение	Размеры (мм)							Установочная пластина	Пластина
	DC	DCONMS	DF	OAL	LU	LPR	LS		
TOP 3051-55-50T2-09CA	51	50	75	278	165	198	80	-	SOMT 09...
	52	50	75	278	165	198	80	TOP-0901	DP/DL/DK/DA
	53	50	75	278	165	198	80	TOP-0902	D146-147
	54	50	75	278	165	198	80	TOP-0903	
	55	50	75	278	165	198	80	TOP-0904	
TOP 3056-60-50T2-11CA	56	50	75	296	180	216	80	-	SOMT 11...
	57	50	75	296	180	216	80	TOP-0901	DP/DL/DK/DA
	58	50	75	296	180	216	80	TOP-0902	D146-147
	59	50	75	296	180	216	80	TOP-0903	
	60	50	75	296	180	216	80	TOP-0904	
TOP 3061-65-50T2-11CA	61	50	75	314	195	234	80	-	SOMT 11...
	62	50	75	314	195	234	80	TOP-0901	DP/DL/DK/DA
	63	50	75	314	195	234	80	TOP-0902	D146-147
	64	50	75	314	195	234	80	TOP-0903	
	65	50	75	314	195	234	80	TOP-0904	
TOP 3066-70-50T2-11CA	66	50	75	332	210	252	80	-	SOMT 11...
	67	50	75	332	210	252	80	TOP-0901	DP/DL/DK/DA
	68	50	75	332	210	252	80	TOP-0902	D146-147
	69	50	75	332	210	252	80	TOP-0903	
	70	50	75	332	210	252	80	TOP-0904	
TOP 3071-75-50T2-13CA	71	50	75	350	225	270	80	-	SOMT 13...
	72	50	75	350	225	270	80	TOP-0901	DP/DL/DK/DA
	73	50	75	350	225	270	80	TOP-0902	D146-147
	74	50	75	350	225	270	80	TOP-0903	
	75	50	75	350	225	270	80	TOP-0904	
TOP 3076-80-50T2-13CA	76	50	75	368	240	288	80	-	SOMT 13...
	77	50	75	368	240	288	80	TOP-0901	DP/DL/DK/DA
	78	50	75	368	240	288	80	TOP-0902	D146-147
	79	50	75	368	240	288	80	TOP-0903	
	80	50	75	368	240	288	80	TOP-0904	



TOP 40...CA

TOPDRILL

Сверло со сменными картриджами



• Глубина сверления: 4xD

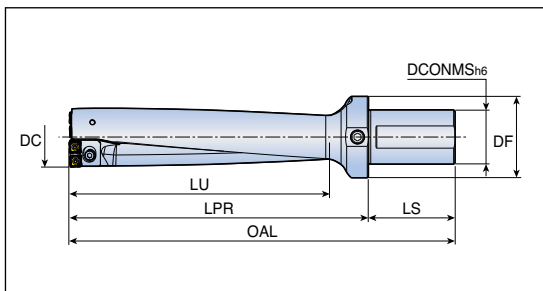

Обозначение	Размеры (мм)							Установочная пластина	Пластина
	DC	DCONMS	DF	OAL	LU	LPR	LS		
TOP 4051-55-50T2-09CA	51	50	75	333	220	253	80	-	SOMT 09... DP/DL/DK/DA
	52	50	75	333	220	253	80	TOP-0901	D146-147
	53	50	75	333	220	253	80	TOP-0902	
	54	50	75	333	220	253	80	TOP-0903	
	55	50	75	333	220	253	80	TOP-0904	
TOP 4056-60-50T2-11CA	56	50	75	356	240	276	80	-	
	57	50	75	356	240	276	80	TOP-0901	D146-147
	58	50	75	356	240	276	80	TOP-0902	
	59	50	75	356	240	276	80	TOP-0903	
	60	50	75	356	240	276	80	TOP-0904	
TOP 4061-65-50T2-11CA	61	50	75	379	260	299	80	-	
	62	50	75	379	260	299	80	TOP-0901	D146-147
	63	50	75	379	260	299	80	TOP-0902	
	64	50	75	379	260	299	80	TOP-0903	
	65	50	75	379	260	299	80	TOP-0904	
TOP 4066-70-50T2-11CA	66	50	75	402	280	322	80	-	
	67	50	75	402	280	322	80	TOP-0901	D146-147
	68	50	75	402	280	322	80	TOP-0902	
	69	50	75	402	280	322	80	TOP-0903	
	70	50	75	402	280	322	80	TOP-0904	
TOP 4071-75-50T2-13CA	71	50	75	425	300	345	80	-	
	72	50	75	425	300	345	80	TOP-0901	D146-147
	73	50	75	425	300	345	80	TOP-0902	
	74	50	75	425	300	345	80	TOP-0903	
	75	50	75	425	300	345	80	TOP-0904	
TOP 4076-80-50T2-13CA	76	50	75	448	320	368	80	-	
	77	50	75	448	320	368	80	TOP-0901	D146-147
	78	50	75	448	320	368	80	TOP-0902	
	79	50	75	448	320	368	80	TOP-0903	
	80	50	75	448	320	368	80	TOP-0904	



Сверло со сменными картриджами

Комплектующие

Обозначение	Винт	Картридж периферийный	Картридж центральный
TOP ..51-55-50T2-09CA	TS 35088I	TOP 09CA-P1	TOP 09CA-C1
TOP ..56-60-50T2-11CA	TS 35088I	TOP 11CA-P1	TOP 11CA-C1
TOP ..61-65-50T2-11CA	TS 35088I	TOP 11CA-P2	TOP 11CA-C2
TOP ..66-70-50T2-11CA	TS 35088I	TOP 11CA-P3	TOP 11CA-C3
TOP ..71-75-50T2-13CA	TS 40093I	TOP 13CA-P1	TOP 13CA-C1
TOP ..76-80-50T2-13CA	TS 40093I	TOP 13CA-P2	TOP 13CA-C2

Комплектующие для картриджей

Обозначение	Винт картриджа	Шайба	Винт установочной пластины
TOP 09CA-P1	SH M4x0.7x16	MW 4.3x8	TS 20043I/HG-P
TOP 09CA-C1	SH M4x0.7x16	MW 4.3x8	-
TOP 11CA-P1	SH M5x0.8x16	MW 5.5x10	TS 20043I/HG-P
TOP 11CA-C1	SH M5x0.8x16	MW 5.5x10	-
TOP 11CA-P2	SH M5x0.8x16	MW 5.5x10	TS 20043I/HG-P
TOP 11CA-C2	SH M5x0.8x16	MW 5.5x10	-
TOP 11CA-P3	SH M5x0.8x16	MW 5.5x10	TS 20043I/HG-P
TOP 11CA-C3	SH M5x0.8x16	MW 5.5x10	-
TOP 13CA-P1	SH M6x1.0x20	MW 6.4x12	TS 20043I/HG-P
TOP 13CA-C1	SH M6x1.0x20	MW 6.4x12	-
TOP 13CA-P2	SH M6x1.0x20	MW 6.4x12	TS 20043I/HG-P
TOP 13CA-C2	SH M6x1.0x20	MW 6.4x12	-

TDR 2...-T2



Сверло со сменными пластинами



• Глубина сверления: 2xD

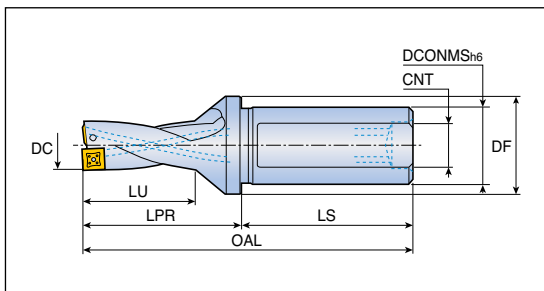

Обозначение	Размеры (мм)							Пластина
	DC	DCONMS	DF	LU	LPR	LS	CNT	
TDR 2125-20T2-05	12.5	20	25	26	44	50	M13X1.0	SPMG 05...
2130-20T2-05	13.0	20	25	26	44	50	M13X1.0	DG/DK/DA
2135-20T2-05	13.5	20	25	28	46	50	M13X1.0	D148-149
2140-20T2-05	14.0	20	25	28	46	50	M13X1.0	
2145-20T2-05	14.5	20	25	30	49	50	M13X1.0	
2150-20T2-05	15.0	20	25	30	49	50	M13X1.0	
2155-25T2-06	15.5	25	32	32	52	56	M16X1.5	SPMG 06...
2160-25T2-06	16.0	25	32	32	52	56	M16X1.5	DG/DK/DA
2165-25T2-06	16.5	25	32	34	54	56	M16X1.5	D148-149
2170-25T2-06	17.0	25	32	34	54	56	M16X1.5	
2175-25T2-06	17.5	25	32	36	57	56	M16X1.5	
2180-25T2-06	18.0	25	32	36	57	56	M16X1.5	
2185-25T2-06	18.5	25	32	38	59	56	M16X1.5	
2190-25T2-06	19.0	25	32	38	59	56	M16X1.5	
2195-25T2-06	19.5	25	32	40	63	56	M16X1.5	
2200-25T2-06	20.0	25	32	40	63	56	M16X1.5	
2205-25T2-06	20.5	25	32	42	65	56	M16X1.5	
2210-25T2-06	21.0	25	32	42	65	56	M16X1.5	
2215-25T2-06	21.5	25	32	44	67	56	M16X1.5	
2220-25T2-07	22.0	25	32	44	67	56	M16X1.5	SPMG 07...
2225-25T2-07	22.5	25	45	46	71	56	M16X1.5	DG/DK/DA
2225-32T2-07	22.5	32	45	46	71	60	M22X2.0	D148-149
2230-25T2-07	23.0	25	45	46	71	56	M16X1.5	
2230-32T2-07	23.0	32	45	46	71	60	M22X2.0	
2235-25T2-07	23.5	25	45	48	74	56	M16X1.5	
2235-32T2-07	23.5	32	45	48	74	60	M22X2.0	
2240-25T2-07	24.0	25	45	48	74	56	M16X1.5	
2240-32T2-07	24.0	32	45	48	74	60	M22X2.0	
2245-25T2-07	24.5	25	45	50	77	56	M16X1.5	
2245-32T2-07	24.5	32	45	50	77	60	M22X2.0	
2250-25T2-07	25.0	25	45	50	77	56	M16X1.5	
2250-32T2-07	25.0	32	45	50	77	60	M22X2.0	
2255-25T2-07	25.5	25	45	52	79	56	M16X1.5	
2255-32T2-07	25.5	32	45	52	79	60	M22X2.0	
2260-25T2-07	26.0	25	45	52	79	56	M16X1.5	

• OAL = LPR+LS



TDR 2...-T2

Сверло со сменными пластинами



• Глубина сверления: 2xD

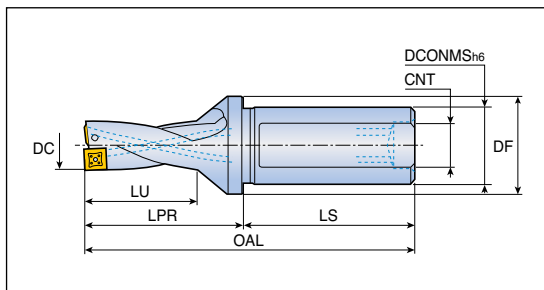

Обозначение	Размеры (мм)							Пластина
	DC	DCONMS	DF	LU	LPR	LS	CNT	
TDR 2260-32T2-07	26.0	32	45	52	79	60	M22X2.0	SPMG 07... DG/DK/DA D148-149
2265-25T2-07	26.5	25	45	54	81	56	M16X1.5	
2265-32T2-07	26.5	32	45	54	81	60	M22X2.0	
2270-25T2-07	27.0	25	45	54	81	56	M16X1.5	
2270-32T2-07	27.0	32	45	54	81	60	M22X2.0	
2275-25T2-07	27.5	25	45	56	84	56	Rc 1/8	
2275-32T2-07	27.5	32	45	56	84	60	Rc 1/4	
2280-25T2-09	28.0	25	45	56	84	56	Rc 1/8	SPMG 09... DG/DK/DA D148-149
2280-32T2-09	28.0	32	45	56	84	60	Rc 1/4	
2285-25T2-09	28.5	25	45	58	86	56	Rc 1/8	
2285-32T2-09	28.5	32	45	58	86	60	Rc 1/4	
2290-25T2-09	29.0	25	45	58	86	56	Rc 1/8	
2290-32T2-09	29.0	32	45	58	86	60	Rc 1/4	
2295-32T2-09	29.5	32	55	60	91	60	Rc 1/4	
2295-40T2-09	29.5	40	55	60	91	70	Rc 1/4	
2300-32T2-09	30.0	32	55	60	91	60	Rc 1/4	
2300-40T2-09	30.0	40	55	60	91	70	Rc 1/4	
2305-32T2-09	30.5	32	55	62	94	60	Rc 1/4	
2305-40T2-09	30.5	40	55	62	94	70	Rc 1/4	
2310-32T2-09	31.0	32	55	62	94	60	Rc 1/4	
2310-40T2-09	31.0	40	55	62	94	70	Rc 1/4	
2315-32T2-09	31.5	32	55	64	96	60	Rc 1/4	
2315-40T2-09	31.5	40	55	64	96	70	Rc 1/4	
2320-32T2-09	32.0	32	55	64	96	60	Rc 1/4	
2320-40T2-09	32.0	40	55	64	96	70	Rc 1/4	
2325-32T2-09	32.5	32	55	66	99	60	Rc 1/4	
2325-40T2-09	32.5	40	55	66	99	70	Rc 1/4	
2330-32T2-09	33.0	32	55	66	99	60	Rc 1/4	
2330-40T2-09	33.0	40	55	66	99	70	Rc 1/4	
2340-32T2-11	34.0	32	55	68	101	60	Rc 1/4	SPMG 11... DG/DA/DK D148-149
2340-40T2-11	34.0	40	55	68	101	70	Rc 1/4	
2350-32T2-11	35.0	32	55	70	104	60	Rc 1/4	
2350-40T2-11	35.0	40	55	70	104	70	Rc 1/4	
2360-32T2-11	36.0	32	55	72	107	60	Rc 1/4	
2360-40T2-11	36.0	40	55	72	107	70	Rc 1/4	

• OAL = LPR+LS



Сверло со сменными пластинами



• Глубина сверления: 2xD

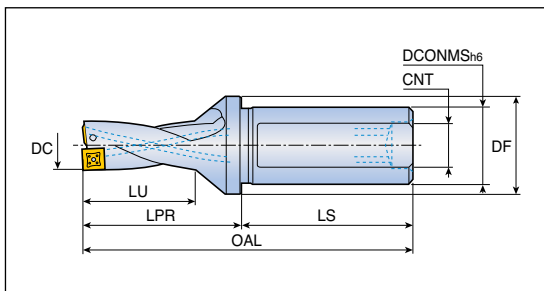

Обозначение	Размеры (мм)							Пластина	
	DC	DCONMS	DF	LU	LPR	LS	CNT		
TDR 2370-32T2-11	37.0	32	55	74	110	60	Rc 1/4	SPMG 11... DG/DK/DA D148-149	
2370-40T2-11	37.0	40	55	74	110	70	Rc 1/4		
2380-32T2-11	38.0	32	55	76	113	60	Rc 1/4		
2380-40T2-11	38.0	40	55	76	113	70	Rc 1/4		
2390-32T2-11	39.0	32	55	78	115	60	Rc 1/4		
2390-40T2-11	39.0	40	55	78	115	70	Rc 1/4		
2400-32T2-11	40.0	32	60	80	118	60	Rc 1/4		
2400-40T2-11	40.0	40	60	80	118	70	Rc 1/4		
2410-40T2-11	41.0	40	60	82	121	70	Rc 1/4		
2420-40T2-14	42.0	40	60	84	123	70	Rc 1/4		SPMG 14... DG/DK/DA D148-149
2430-40T2-14	43.0	40	60	86	126	70	Rc 1/4		
2440-40T2-14	44.0	40	60	88	128	70	Rc 1/4		
2450-40T2-14	45.0	40	60	90	132	70	Rc 1/4		
2460-40T2-14	46.0	40	60	92	135	70	Rc 1/4		
2470-40T2-14	47.0	40	60	94	137	70	Rc 1/4		
2480-40T2-14	48.0	40	60	96	140	70	Rc 1/4		
2490-40T2-14	49.0	40	60	98	142	70	Rc 1/4		
2500-40T2-14	50.0	40	60	100	145	70	Rc 1/4		

• OAL = LPR + LS

Комплектующие

Обозначение	Винт	Ключ	Заглушка	
TDR 2125 - 2150	TS 20043I/HG-P	TD 6P	SL 20 M	
TDR 2155 - 2215	TS 22052I/HG	TD 7	SL 25 M	
TDR 2220 - 2270	TS 25064I	TD 8	SL 25 M / SL 32 M	
TDR 2275	TS 25064I	TD 8	-	
TDR 2280 - 2330	TS 35088I	TD 10	-	
TDR 2340 - 2390	TS 40093I	TD 15	-	
TDR 2400 - 2410	TS 40093I	TD 15	-	
TDR 2420 - 2500	SO 50090I	TD 20	-	



TDR 3...-T2

Сверло со сменными пластинами



• Глубина сверления: 3xD

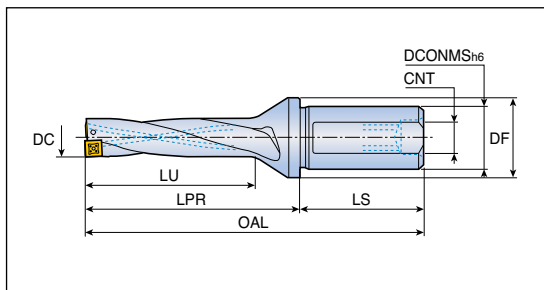

Обозначение	Размеры (мм)							Пластина
	DC	DCONMS	DF	LU	LPR	LS	CNT	
TDR 3125-20T2-05	12.5	20	25	39	57	50	M13X1.0	SPMG 05... DG/DK/DA D148-149
3130-20T2-05	13.0	20	25	39	57	50	M13X1.0	
3135-20T2-05	13.5	20	25	42	60	50	M13X1.0	
3140-20T2-05	14.0	20	25	42	60	50	M13X1.0	
3145-20T2-05	14.5	20	25	45	64	50	M13X1.0	
3150-20T2-05	15.0	20	25	45	64	50	M13X1.0	SPMG 06... DG/DK/DA D148-149
3155-25T2-06	15.5	25	32	48	68	56	M16X1.5	
3160-25T2-06	16.0	25	32	48	68	56	M16X1.5	
3165-25T2-06	16.5	25	32	51	71	56	M16X1.5	
3170-25T2-06	17.0	25	32	51	71	56	M16X1.5	
3175-25T2-06	17.5	25	32	54	75	56	M16X1.5	
3180-25T2-06	18.0	25	32	54	75	56	M16X1.5	
3185-25T2-06	18.5	25	32	57	78	56	M16X1.5	
3190-25T2-06	19.0	25	32	57	78	56	M16X1.5	
3195-25T2-06	19.5	25	32	60	83	56	M16X1.5	
3200-25T2-06 *	20.0	25	32	60	83	56	M16X1.5	
3205-25T2-06	20.5	25	32	63	86	56	M16X1.5	
3209-25T2-06 *	20.9	25	32	63	86	56	M16X1.5	
3210-25T2-06	21.0	25	32	63	86	56	M16X1.5	
3215-25T2-06	21.5	25	32	66	89	56	M16X1.5	
3220-25T2-07	22.0	25	32	66	89	56	M16X1.5	SPMG 07... DG/DK/DA D148-149
3225-25T2-07	22.5	25	45	69	94	56	M16X1.5	
3225-32T2-07	22.5	32	45	69	94	60	M22X2.0	
3230-25T2-07	23.0	25	45	69	94	56	M16X1.5	
3230-32T2-07	23.0	32	45	69	94	60	M22X2.0	
3235-25T2-07	23.5	25	45	72	98	56	M16X1.5	
3235-32T2-07	23.5	32	45	72	98	60	M22X2.0	
3239-25T2-07 *	23.9	25	32	72	98	56	M16X1.5	
3239-32T2-07 *	23.9	32	45	72	98	60	M22X2.0	
3240-25T2-07	24.0	25	45	72	98	56	M16X1.5	
3240-32T2-07	24.0	32	45	72	98	60	M22X2.0	
3245-25T2-07	24.5	25	45	75	102	56	M16X1.5	
3245-32T2-07	24.5	32	45	75	102	60	M22X2.0	
3250-25T2-07	25.0	25	45	75	102	56	M16X1.5	
3250-32T2-07	25.0	32	45	75	102	60	M22X2.0	



- *! Сверла для отверстий под резьбу
- OAL = LPR+LS

Сверло со сменными пластинами



• Глубина сверления: 3xD

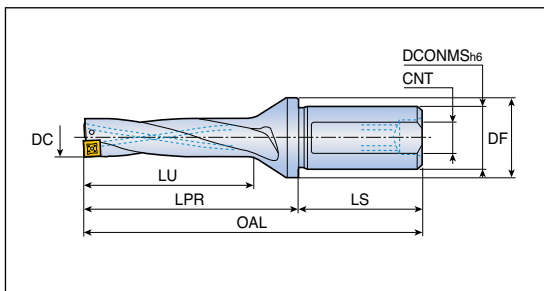

Обозначение	Размеры (мм)							Пластина
	DC	DCONMS	DF	LU	LPR	LS	CNT	
TDR 3255-25T2-07	25.5	25	45	78	105	56	M16X1.5	SPMG 07... DG/DK/DA D148-149
3255-32T2-07	25.5	32	45	78	105	60	M22X2.0	
3260-25T2-07	26.0	25	45	78	105	56	M16X1.5	
3260-32T2-07	26.0	32	45	78	105	60	M22X2.0	
3264-25T2-07 *	26.4	25	45	81	108	56	M16X1.5	
3264-32T2-07 *	26.4	32	45	81	108	60	M22X2.0	
3265-25T2-07	26.5	25	45	81	108	56	M16X1.5	
3265-32T2-07	26.5	32	45	81	108	60	M22X2.0	
3270-25T2-07	27.0	25	45	81	108	56	M16X1.5	
3270-32T2-07	27.0	32	45	81	108	60	M22X2.0	
3275-25T2-07	27.5	25	45	84	112	56	Rc 1/8	
3275-32T2-07	27.5	32	45	84	112	60	Rc 1/4	
3280-25T2-09	28.0	25	45	84	112	56	Rc 1/8	SPMG 09... DG/DK/DA D148-149
3280-32T2-09	28.0	32	45	84	112	60	Rc 1/4	
3285-25T2-09	28.5	25	45	87	115	56	Rc 1/8	
3285-32T2-09	28.5	32	45	87	115	56	Rc 1/4	
3290-25T2-09	29.0	25	45	87	115	56	Rc 1/8	
3290-32T2-09	29.0	32	45	87	115	60	Rc 1/4	
3294-32T2-09 *	29.4	32	55	90	121	60	Rc 1/4	
3294-40T2-09 *	29.4	40	55	90	121	70	Rc 1/4	
3295-32T2-09	29.5	32	55	90	121	60	Rc 1/4	
3295-40T2-09	29.5	40	55	90	121	70	Rc 1/4	
3300-32T2-09	30.0	32	55	90	121	60	Rc 1/4	
3300-40T2-09	30.0	40	55	90	121	70	Rc 1/4	
3305-32T2-09	30.5	32	55	93	125	60	Rc 1/4	
3305-40T2-09	30.5	40	55	93	125	70	Rc 1/4	
3310-32T2-09	31.0	32	55	93	125	60	Rc 1/4	
3310-40T2-09	31.0	40	55	93	125	70	Rc 1/4	
3315-32T2-09	31.5	32	55	96	128	60	Rc 1/4	
3315-40T2-09	31.5	40	55	96	128	70	Rc 1/4	
3320-32T2-09	32.0	32	55	96	128	60	Rc 1/4	
3320-40T2-09	32.0	40	55	96	128	70	Rc 1/4	



- **1* Сверла для отверстий под резьбу
- OAL = LPR+LS

TDR 3...-T2

Сверло со сменными пластинами



• Глубина сверления: 3xD

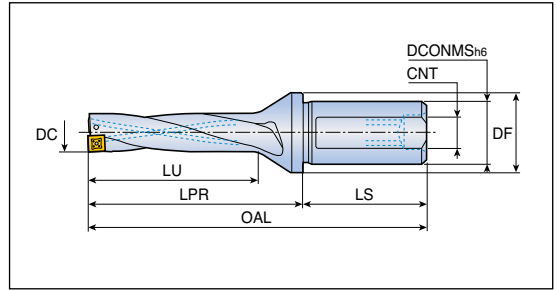

Обозначение	Размеры (мм)							Пластина
	DC	DCONMS	DF	LU	LPR	LS	CNT	
TDR 3325-32T2-09	32.5	32	55	99	132	60	Rc 1/4	SPMG 09... DG/DK/DA D148-149
3325-40T2-09	32.5	40	55	99	132	70	Rc 1/4	
3330-32T2-09	33.0	32	55	99	132	60	Rc 1/4	
3330-40T2-09	33.0	40	55	99	132	70	Rc 1/4	
3340-32T2-11	34.0	32	55	102	135	60	Rc 1/4	SPMG 11... DG/DK/DA D148-149
3340-40T2-11	34.0	40	55	102	135	70	Rc 1/4	
3350-32T2-11	35.0	32	55	105	139	60	Rc 1/4	
3350-40T2-11	35.0	40	55	105	139	70	Rc 1/4	
3360-32T2-11	36.0	32	55	108	143	60	Rc 1/4	Rc 1/4
3360-40T2-11	36.0	40	55	108	143	70	Rc 1/4	
3370-32T2-11	37.0	32	55	111	147	60	Rc 1/4	Rc 1/4
3370-40T2-11	37.0	40	55	111	147	70	Rc 1/4	
3375-32T2-11 *	37.5	32	55	114	151	60	Rc 1/4	Rc 1/4
3375-40T2-11 *	37.5	40	55	114	151	70	Rc 1/4	
3380-32T2-11	38.0	32	55	114	151	60	Rc 1/4	Rc 1/4
3380-40T2-11	38.0	40	55	114	151	70	Rc 1/4	
3390-32T2-11	39.0	32	55	117	154	60	Rc 1/4	Rc 1/4
3390-40T2-11	39.0	40	55	117	154	70	Rc 1/4	
3400-32T2-11	40.0	32	60	120	158	60	Rc 1/4	Rc 1/4
3400-40T2-11	40.0	40	60	120	158	70	Rc 1/4	
3405-40T2-11 *	40.5	40	60	123	162	70	Rc 1/4	Rc 1/4
3410-40T2-11	41.0	40	60	123	162	70	Rc 1/4	



• *! Сверла для отверстий под резьбу
• OAL = LPR+LS

TDR 3...-T2



Сверло со сменными пластинами



• Глубина сверления: 3xD

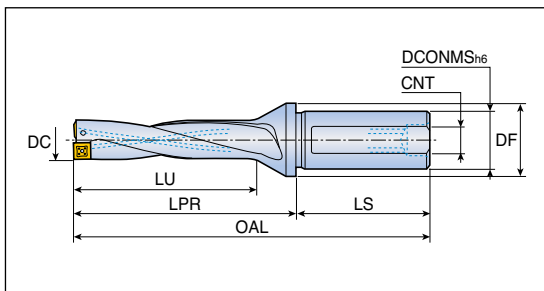

Обозначение	Размеры (мм)							Пластина
	DC	DCONMS	DF	LU	LPR	LS	CNT	
TDR 3420-40T2-14	42.0	40	60	126	165	70	Rc 1/4	SPMG 14... DG/DK/DA D148-149
3430-40T2-14	43.0	40	60	129	169	70	Rc 1/4	
3440-40T2-14	44.0	40	60	132	172	70	Rc 1/4	
3450-40T2-14	45.0	40	60	135	177	70	Rc 1/4	
3460-40T2-14	46.0	40	60	138	181	70	Rc 1/4	
3470-40T2-14	47.0	40	60	141	184	70	Rc 1/4	
3480-40T2-14	48.0	40	60	144	188	70	Rc 1/4	
3490-40T2-14	49.0	40	60	147	191	70	Rc 1/4	
3500-40T2-14	50.0	40	60	150	195	70	Rc 1/4	

• OAL = LPR+LS

Комплектующие

Обозначение	Винт	Ключ	Заглушка	
TDR 3125 - 3150	TS 20043I/HG-P	TD 6P	SL 20 M	
TDR 3155 - 3215	TS 22052I/HG	TD 7	SL 25 M	
TDR 3220 - 3270	TS 25064I	TD 8	SL 25 M / SL 32 M	
TDR 3275	TS 25064I	TD 8	-	
TDR 3280 - 3330	TS 35088I	TD 10	-	
TDR 3340 - 3390	TS 40093I	TD 15	-	
TDR 3400 - 3410	TS 40093I	TD 15	-	
TDR 3420 - 3500	SO 50090I	TD 20	-	



TDR 4...-T2



Сверло со сменными пластинами



• Глубина сверления: 4xD

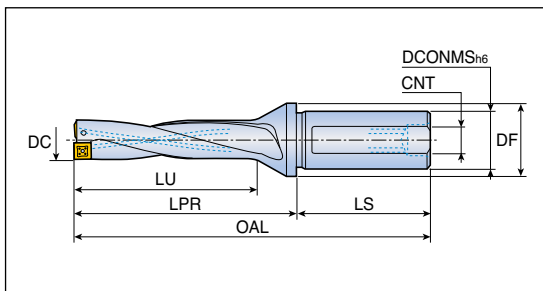

Обозначение	Размеры (мм)							Пластина
	DC	DCONMS	DF	LU	LPR	LS	CNT	
TDR 4125-20T2-05	12.5	20	25	52	70	50	M13X1.0	SPMG 05... DG/DK/DA D148-149
4130-20T2-05	13.0	20	25	52	70	50	M13X1.0	
4135-20T2-05	13.5	20	25	56	74	50	M13X1.0	
4140-20T2-05	14.0	20	25	56	74	50	M13X1.0	
4145-20T2-05	14.5	20	25	60	79	50	M13X1.0	
4150-20T2-05	15.0	20	25	60	79	50	M13X1.0	SPMG 06... DG/DK/DA D148-149
4155-25T2-06	15.5	25	32	64	84	56	M16X1.5	
4160-25T2-06	16.0	25	32	64	84	56	M16X1.5	
4165-25T2-06	16.5	25	32	68	88	56	M16X1.5	
4170-25T2-06	17.0	25	32	68	88	56	M16X1.5	
4175-25T2-06	17.5	25	32	72	93	56	M16X1.5	
4180-25T2-06	18.0	25	32	72	93	56	M16X1.5	
4185-25T2-06	18.5	25	32	76	97	56	M16X1.5	
4190-25T2-06	19.0	25	32	76	97	56	M16X1.5	
4195-25T2-06	19.5	25	32	80	103	56	M16X1.5	
4200-25T2-06	20.0	25	32	80	103	56	M16X1.5	
4205-25T2-06	20.5	25	32	84	107	56	M16X1.5	
4210-25T2-06	21.0	25	32	84	107	56	M16X1.5	
4215-25T2-06	21.5	25	32	88	111	56	M16X1.5	
4220-25T2-07	22.0	25	32	88	111	56	M16X1.5	
4225-25T2-07	22.5	25	45	92	117	56	M16X1.5	
4225-32T2-07	22.5	32	45	92	117	60	M22X2.0	
4230-25T2-07	23.0	25	45	92	117	56	M16X1.5	
4230-32T2-07	23.0	32	45	92	117	60	M22X2.0	
4235-25T2-07	23.5	25	45	96	122	56	M16X1.5	
4235-32T2-07	23.5	32	45	96	122	60	M22X2.0	
4240-25T2-07	24.0	25	45	96	122	56	M16X1.5	
4240-32T2-07	24.0	32	45	96	122	60	M22X2.0	
4245-25T2-07	24.5	25	45	100	127	56	M16X1.5	
4245-32T2-07	24.5	32	45	100	127	60	M22X2.0	
4250-25T2-07	25.0	25	45	100	127	56	M16X1.5	
4250-32T2-07	25.0	32	45	100	127	60	M22X2.0	
4255-25T2-07	25.5	25	45	104	131	56	M16X1.5	
4255-32T2-07	25.5	32	45	104	131	60	M22X2.0	
4260-25T2-07	26.0	25	45	104	131	56	M16X1.5	

• OAL = LPR+LS



TDR 4...-T2







Сверло со сменными пластинами

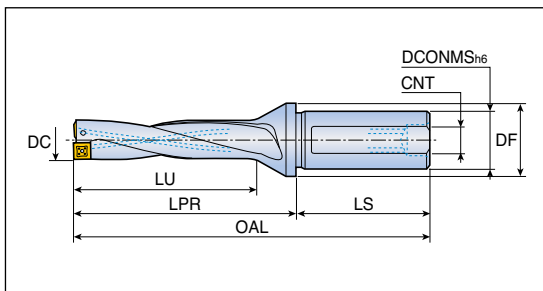

• Глубина сверления: 4xD



Обозначение	Размеры (мм)							Пластина
	DC	DCONMS	DF	LU	LPR	LS	CNT	
TDR 4260-32T2-07	26.0	32	45	104	131	60	M22X2.0	SPMG 07... DG/DK/DA  D148-149
4265-25T2-07	26.5	25	45	108	135	56	M16X1.5	
4265-32T2-07	26.5	32	45	108	135	60	M22X2.0	
4270-25T2-07	27.0	25	45	108	135	56	M16X1.5	
4270-32T2-07	27.0	32	45	108	135	60	M22X2.0	
4275-25T2-07	27.5	25	45	112	140	56	Rc 1/8	
4275-32T2-07	27.5	32	45	112	140	60	Rc 1/4	
4280-25T2-09	28.0	25	45	112	140	56	Rc 1/8	SPMG 09... DG/DK/DA  D148-149
4280-32T2-09	28.0	32	45	112	140	60	Rc 1/4	
4285-25T2-09	28.5	25	45	116	144	56	Rc 1/8	
4285-32T2-09	28.5	32	45	116	144	60	Rc 1/4	
4290-25T2-09	29.0	25	45	116	144	56	Rc 1/8	
4290-32T2-09	29.0	32	45	116	144	60	Rc 1/4	
4295-32T2-09	29.5	32	55	120	151	60	Rc 1/4	
4295-40T2-09	29.5	40	55	120	151	70	Rc 1/4	
4300-32T2-09	30.0	32	55	120	151	60	Rc 1/4	SPMG 11... DG/DK/DA  D148-149
4300-40T2-09	30.0	40	55	120	151	70	Rc 1/4	
4305-32T2-09	30.5	32	55	124	156	60	Rc 1/4	
4305-40T2-09	30.5	40	55	124	156	70	Rc 1/4	
4310-32T2-09	31.0	32	55	124	156	60	Rc 1/4	
4310-40T2-09	31.0	40	55	124	156	70	Rc 1/4	
4315-32T2-09	31.5	32	55	128	160	60	Rc 1/4	
4315-40T2-09	31.5	40	55	128	160	70	Rc 1/4	
4320-32T2-09	32.0	32	55	128	160	60	Rc 1/4	SPMG 11... DG/DK/DA  D148-149
4320-40T2-09	32.0	40	55	128	160	70	Rc 1/4	
4325-32T2-09	32.5	32	55	132	165	60	Rc 1/4	
4325-40T2-09	32.5	40	55	132	165	70	Rc 1/4	
4330-32T2-09	33.0	32	55	132	165	60	Rc 1/4	
4330-40T2-09	33.0	40	55	132	165	70	Rc 1/4	
4340-32T2-11	34.0	32	55	136	169	60	Rc 1/4	
4340-40T2-11	34.0	40	55	136	169	70	Rc 1/4	
4350-32T2-11	35.0	32	55	140	174	60	Rc 1/4	SPMG 11... DG/DK/DA  D148-149
4350-40T2-11	35.0	40	55	140	174	70	Rc 1/4	
4360-32T2-11	36.0	32	55	144	179	60	Rc 1/4	
4360-40T2-11	36.0	40	55	144	179	70	Rc 1/4	

• OAL = LPR+LS



TDR 4...-T2



Сверло со сменными пластинами



- Глубина сверления: 4xD

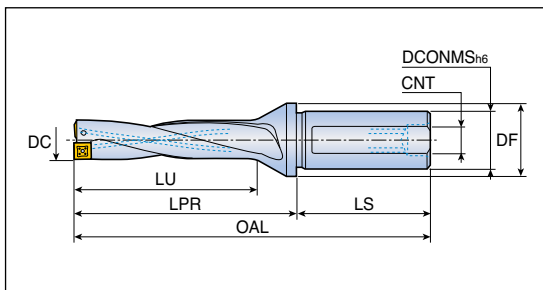

Обозначение	Размеры (мм)							Пластина
	DC	DCONMS	DF	LU	LPR	LS	CNT	
TDR 4370-32T2-11	37.0	32	55	148	184	60	Rc 1/4	SPMG 11... DG/DK/DA D148-149
4370-40T2-11	37.0	40	55	148	184	70	Rc 1/4	
4380-32T2-11	38.0	32	55	152	189	60	Rc 1/4	
4380-40T2-11	38.0	40	55	152	189	70	Rc 1/4	
4390-32T2-11	39.0	32	55	156	193	60	Rc 1/4	
4390-40T2-11	39.0	40	55	156	193	70	Rc 1/4	
4400-32T2-11	40.0	32	60	160	198	60	Rc 1/4	
4400-40T2-11	40.0	40	60	160	198	70	Rc 1/4	
4410-40T2-11	41.0	40	60	164	203	70	Rc 1/4	
4420-40T2-14	42.0	40	60	168	207	70	Rc 1/4	
4430-40T2-14	43.0	40	60	172	212	70	Rc 1/4	
4440-40T2-14	44.0	40	60	176	216	70	Rc 1/4	
4450-40T2-14	45.0	40	60	180	222	70	Rc 1/4	
4460-40T2-14	46.0	40	60	184	227	70	Rc 1/4	
4470-40T2-14	47.0	40	60	188	231	70	Rc 1/4	
4480-40T2-14	48.0	40	60	192	236	70	Rc 1/4	
4490-40T2-14	49.0	40	60	196	240	70	Rc 1/4	
4500-40T2-14	50.0	40	60	200	245	70	Rc 1/4	

- OAL = LPR+LS

Комплектующие

Обозначение	Винт 	Ключ 	Заглушка 	
TDR 4125 - 4150	TS 20043I/HG-P	TD 6P	SL 20 M	
TDR 4155 - 4215	TS 22052I/HG	TD 7	SL 25 M	
TDR 4220 - 4270	TS 25064I	TD 8	SL 25 M / SL 32 M	
TDR 4275	TS 25064I	TD 8	-	
TDR 4280 - 4330	TS 35088I	TD 10	-	
TDR 4340 - 4390	TS 40093I	TD 15	-	
TDR 4400 - 4410	TS 40093I	TD 15	-	
TDR 4420 - 4500	SO 50090I	TD 20	-	



TDR 5...-T2



Сверло со сменными пластинами



• Глубина сверления: 5xD

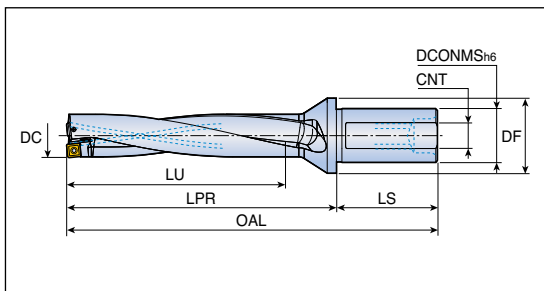

Обозначение	Размеры (мм)							Пластина	
	DC	DCONMS	DF	LU	LPR	LS	CNT		
TDR 5125-20T2-05	12.5	20	25	65	83	50	M13X1.0	SPMG 05... DG/DK/DA D148-149	
5130-20T2-05	13.0	20	25	65	83	50	M13X1.0		
5135-20T2-05	13.5	20	25	70	88	50	M13X1.0		
5140-20T2-05	14.0	20	25	70	88	50	M13X1.0		
5145-20T2-05	14.5	20	25	75	94	50	M13X1.0		
5150-20T2-05	15.0	20	25	75	94	50	M13X1.0	SPMG 06... DG/DK/DA D148-149	
5155-25T2-06	15.5	25	32	80	100	56	M16X1.5		
5160-25T2-06	16.0	25	32	80	100	56	M16X1.5		
5165-25T2-06	16.5	25	32	85	105	56	M16X1.5		
5170-25T2-06	17.0	25	32	85	105	56	M16X1.5		
5175-25T2-06	17.5	25	32	90	111	56	M16X1.5		
5180-25T2-06	18.0	25	32	90	111	56	M16X1.5		
5185-25T2-06	18.5	25	32	95	116	56	M16X1.5		
5190-25T2-06	19.0	25	32	95	116	56	M16X1.5		
5195-25T2-06	19.5	25	32	100	123	56	M16X1.5		
5200-25T2-06	20.0	25	32	100	123	56	M16X1.5		
5205-25T2-06	20.5	25	32	105	128	56	M16X1.5		
5210-25T2-06	21.0	25	32	105	128	56	M16X1.5		
5215-25T2-06	21.5	25	32	110	133	56	M16X1.5		
5220-25T2-07	22.0	25	32	110	133	56	M22X2.0		SPMG 07... DG/DK/DA D148-149
5225-32T2-07	22.5	32	45	115	140	60	M22X2.0		
5230-32T2-07	23.0	32	45	115	140	60	M22X2.0		
5235-32T2-07	23.5	32	45	120	146	60	M22X2.0		
5240-32T2-07	24.0	32	45	120	146	60	M22X2.0		
5245-32T2-07	24.5	32	45	125	152	60	M22X2.0		
5250-32T2-07	25.0	32	45	125	152	60	M22X2.0		
5255-32T2-07	25.5	32	45	130	157	60	M22X2.0		
5260-32T2-07	26.0	32	45	130	157	60	M22X2.0		
5265-32T2-07	26.5	32	45	135	162	60	M22X2.0		
5270-32T2-07	27.0	32	45	135	162	60	M22X2.0		
5275-32T2-07	27.5	32	45	140	168	60	Rc 1/4		

• OAL = LPR+LS



TDR 5...-T2



Сверло со сменными пластинами



• Глубина сверления: 5xD

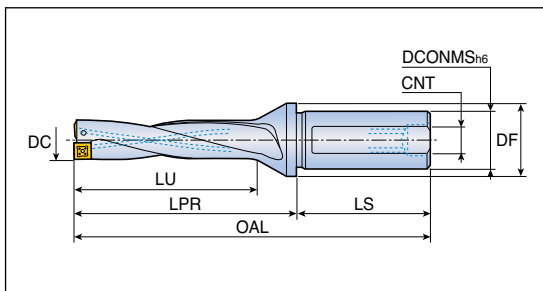

Обозначение	Размеры (мм)							Пластина
	DC	DCONMS	DF	LU	LPR	LS	CNT	
TDR 5280-32T2-09	28.0	32	45	140	168	60	Rc 1/4	SPMG 09... DG/DK/DA D148-149
5285-32T2-09	28.5	32	45	145	173	60	Rc 1/4	
5290-32T2-09	29.0	32	45	145	173	60	Rc 1/4	
5295-32T2-09	29.5	32	55	150	181	60	Rc 1/4	
5300-32T2-09	30.0	32	55	150	181	60	Rc 1/4	
5300-40T2-09	30.0	40	55	150	181	70	Rc 1/4	
5310-32T2-09	31.0	32	55	155	187	60	Rc 1/4	
5310-40T2-09	31.0	40	55	155	187	70	Rc 1/4	
5320-32T2-09	32.0	32	55	160	192	60	Rc 1/4	
5320-40T2-09	32.0	40	55	160	192	70	Rc 1/4	
5330-32T2-09	33.0	32	55	165	198	60	Rc 1/4	SPMG 11... DG/DK/DA D148-149
5330-40T2-09	33.0	40	55	165	198	70	Rc 1/4	
5340-32T2-11	34.0	32	55	170	203	60	Rc 1/4	
5340-40T2-11	34.0	40	55	170	203	70	Rc 1/4	
5350-32T2-11	35.0	32	55	175	209	60	Rc 1/4	
5350-40T2-11	35.0	40	55	175	209	70	Rc 1/4	
5360-32T2-11	36.0	32	55	180	215	60	Rc 1/4	
5360-40T2-11	36.0	40	55	180	215	70	Rc 1/4	
5370-32T2-11	37.0	32	55	185	221	60	Rc 1/4	
5370-40T2-11	37.0	40	55	185	221	70	Rc 1/4	
5380-32T2-11	38.0	32	55	190	227	60	Rc 1/4	
5380-40T2-11	38.0	40	55	190	227	70	Rc 1/4	
5390-32T2-11	39.0	32	55	195	232	60	Rc 1/4	
5390-40T2-11	39.0	40	55	195	232	70	Rc 1/4	
5400-32T2-11	40.0	32	60	200	238	60	Rc 1/4	
5400-40T2-11	40.0	40	60	200	238	70	Rc 1/4	
5410-40T2-11	41.0	40	60	205	244	70	Rc 1/4	

• OAL = LPR+LS



TDR 5...-T2



Сверло со сменными пластинами



• Глубина сверления: 5xD

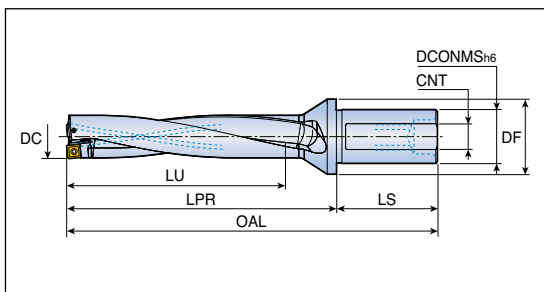

Обозначение	Размеры (мм)							Пластина
	DC	DCONMS	DF	LU	LPR	LS	CNT	
TDR 5420-40T2-14	42.0	40	60	210	249	70	Rc 1/4	SPMG 14... DG/DK/DA D148-149
5430-40T2-14	43.0	40	60	215	255	70	Rc 1/4	
5440-40T2-14	44.0	40	60	220	260	70	Rc 1/4	
5450-40T2-14	45.0	40	60	225	267	70	Rc 1/4	
5460-40T2-14	46.0	40	60	230	273	70	Rc 1/4	
5470-40T2-14	47.0	40	60	235	278	70	Rc 1/4	
5480-40T2-14	48.0	40	60	240	284	70	Rc 1/4	
5490-40T2-14	49.0	40	60	245	289	70	Rc 1/4	
5500-40T2-14	50.0	40	60	250	295	70	Rc 1/4	

• OAL = LPR+LS

Комплектующие

Обозначение	Винт	Ключ	Заглушка	
TDR 5125 - 5150	TS 20043I/HG-P	TD 6P	SL 20 M	
TDR 5155 - 5215	TS 22052I/HG	TD 7	SL 25 M	
TDR 5220 - 5270	TS 25064I	TD 8	SL 25 M / SL 32 M	
TDR 5275	TS 25064I	TD 8	-	
TDR 5280 - 5330	TS 35088I	TD 10	-	
TDR 5340 - 5390	TS 40093I	TD 15	-	
TDR 5400 - 5410	TS 40093I	TD 15	-	
TDR 5420 - 5500	SO 50090I	TD 20	-	



TDR 25...CA-T





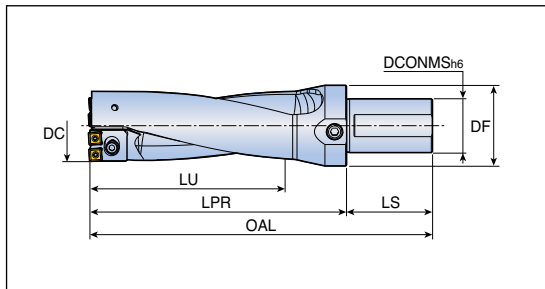



Сверло со сменными картриджами



• Глубина сверления: 2.5xD



Обозначение	Размеры (мм)						Установочная пластина	Пластина	
	DC	DCONMS	DF	LU	LPR	LS			
TDR 2551-53-50T2-07CA-T	51	50	75	133	170	80	-	SPMG 07... DG/DK/DA	
	52	50	75	133	170	80	TDP-0701	 D148-149	
	53	50	75	133	170	80	TDP-0702		
2554-56-50T2-07CA-T	54	50	75	140	180	80	-	SPMG 07... DG/DK/DA	
	55	50	75	140	180	80	TDP-0701	 D148-149	
	56	50	75	140	180	80	TDP-0702		
2557-62-50T2-09CA-T	57	50	75	155	201	80	-	SPMG 09... DG/DK/DA	
	58	50	75	155	201	80	TDP-0901	 D148-149	
	59	50	75	155	201	80	TDP-0902		
	60	50	75	155	201	80	TDP-0903		
	61	50	75	155	201	80	TDP-0904		
	62	50	75	155	201	80	TDP-0905		
2563-66-50T2-09CA-T	63	50	75	165	215	80	-		SPMG 09... DG/DK/DA
	64	50	75	165	215	80	TDP-0901	 D148-149	
	65	50	75	165	215	80	TDP-0902		
	66	50	75	165	215	80	TDP-0903		
2567-73-50T2-11CA-T	67	50	75	183	240	80	-		SPMG 11... DG/DK/DA
	68	50	75	183	240	80	TDP-1101	 D148-149	
	69	50	75	183	240	80	TDP-1102		
	70	50	75	183	240	80	TDP-1103		
	71	50	75	183	240	80	TDP-1104		
	72	50	75	183	240	80	TDP-1105		
	73	50	75	183	240	80	TDP-1106		
2574-80-50T2-12CA-T	74	50	75	200	250	80	-		SPMG 12...DG
	75	50	75	200	250	80	TDP-1101	 D148	
	76	50	75	200	250	80	TDP-1102		
	77	50	75	200	250	80	TDP-1103		
	78	50	75	200	250	80	TDP-1104		
	79	50	75	200	250	80	TDP-1105		
	80	50	75	200	250	80	TDP-1106		

• OAL = LPR+LS



TDR 35...CA-T



Сверло со сменными картриджами



• Глубина сверления: 3.5xD

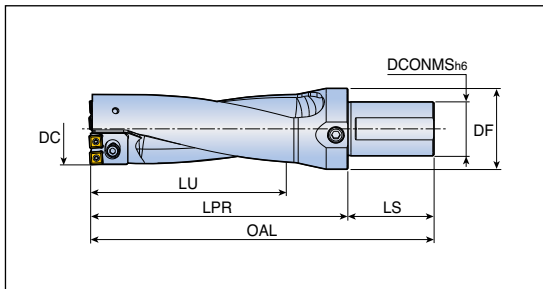

Обозначение	Размеры (мм)						Установочная пластина	Пластина	
	DC	DCONMS	DF	LU	LPR	LS			
TDR 3551-53-50T2-07CA-T	51	50	75	186	223	80	-	SPMG 07... DG/DK/DA	
	52	50	75	186	223	80	TDP-0701	D148-149	
	53	50	75	186	223	80	TDP-0702		
3554-56-50T2-07CA-T	54	50	75	196	236	80	-	SPMG 07... DG/DK/DA	
	55	50	75	196	236	80	TDP-0701	D148-149	
	56	50	75	196	236	80	TDP-0702		
3557-62-50T2-09CA-T	57	50	75	217	263	80	-	SPMG 09... DG/DK/DA	
	58	50	75	217	263	80	TDP-0901	D148-149	
	59	50	75	217	263	80	TDP-0902		
	60	50	75	217	263	80	TDP-0903		
	61	50	75	217	263	80	TDP-0904		
	62	50	75	217	263	80	TDP-0905		
3563-66-50T2-09CA-T	63	50	75	231	281	80	-		SPMG 09... DG/DK/DA
	64	50	75	231	281	80	TDP-0901	D148-149	
	65	50	75	231	281	80	TDP-0902		
	66	50	75	231	281	80	TDP-0903		
3567-73-50T2-11CA-T	67	50	75	256	313	80	-		SPMG 11... DG/DK/DA
	68	50	75	256	313	80	TDP-1101	D148-149	
	69	50	75	256	313	80	TDP-1102		
	70	50	75	256	313	80	TDP-1103		
	71	50	75	256	313	80	TDP-1104		
	72	50	75	256	313	80	TDP-1105		
	73	50	75	256	313	80	TDP-1106		



• OAL = LPR+LS

TDR 35...CA-T



Сверло со сменными картриджами



• Глубина сверления: 3.5xD

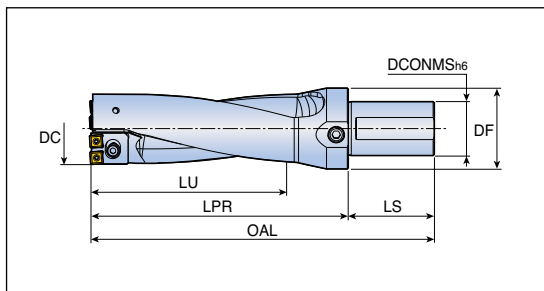

Обозначение	Размеры (мм)						Установочная пластина	Пластина
	DC	DCONMS	DF	LU	LPR	LS		
TDR 3574-80-50T2-12CA-T	74	50	75	280	330	80	-	SPMG 12...DG D148
	75	50	75	280	330	80	TDP-1101	
	76	50	75	280	330	80	TDP-1102	
	77	50	75	280	330	80	TDP-1103	
	78	50	75	280	330	80	TDP-1104	
	79	50	75	280	330	80	TDP-1105	
	80	50	75	280	330	80	TDP-1106	

• OAL = LPR+LS

Комплектующие

Обозначение	Винт	Картридж периферийный	Картридж центральный
TDR.. 51-53...	TS 25064I	TDR 07CA-P1-T	TDR 07CA-C1-T
TDR.. 54-56...	TS 25064I	TDR 07CA-P2-T	TDR 07CA-C2-T
TDR.. 57-62...	TS 35088I	TDR 09CA-P1-T	TDR 09CA-C1-T
TDR.. 63-66...	TS 35088I	TDR 09CA-P2-T	TDR 09CA-C2-T
TDR.. 67-73...	TS 40093I	TDR 11CA-P1-T	TDR 11CA-C1-T
TDR.. 74-80...	TS 40093I	TDR 12CA-P2-T	TDR 12CA-C2-T

Комплектующие для картриджей

Обозначение	Винт картриджа	Шайба	Винт установочной пластины
TDR 07CA-P1-T	SH M4x0.7x16	MW 4.3x8	TS 20043I/HG-P
TDR 07CA-C1-T	SH M4x0.7x16	MW 4.3x8	-
TDR 07CA-P2-T	SH M4x0.7x16	MW 4.3x8	TS 20043I/HG-P
TDR 07CA-C2-T	SH M4x0.7x16	MW 4.3x8	-
TDR 09CA-P1-T	SH M5x0.8x16	MW 5.5x10	SO 30055I
TDR 09CA-C1-T	SH M5x0.8x16	MW 5.5x10	-
TDR 09CA-P2-T	SH M5x0.8x16	MW 5.5x10	SO 30055I
TDR 09CA-C2-T	SH M5x0.8x16	MW 5.5x10	-
TDR 11CA-P1-T	SH M6x1.0x20	MW 6.4x12	SO 30055I
TDR 11CA-C1-T	SH M6x1.0x20	MW 6.4x12	-
TDR 12CA-P2-T	SH M6x1.0x20	MW 6.4x12	SO 30055I
TDR 12CA-C2-T	SH M6x1.0x20	MW 6.4x12	-



ЭКЦЕНТРИКОВАЯ ВТУЛКА

Втулка для центрирования сверла/ Эксцентриковая втулка

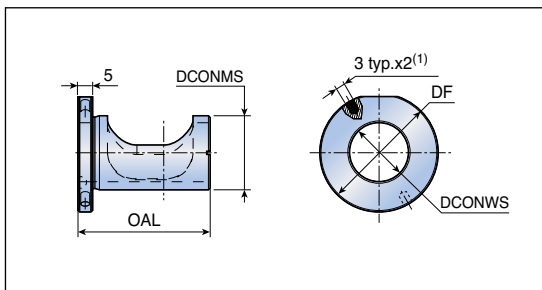

Обозначение	Размеры (мм)			
	DCONWS	DCONMS	DF	OAL
ECCENTER SLEEVE 20x25	20	25	40	44
25x32	25	32	50	46
32x40	32	40	65	55
40x50	40	50	75	62

• ⁽¹⁾ Отверстия под штифт служат для радиального регулирования втулки (штифт не входит в комплект)

3ED...T...-3D

Трехперое сверло со сменными головками с хвостовиком Weldon

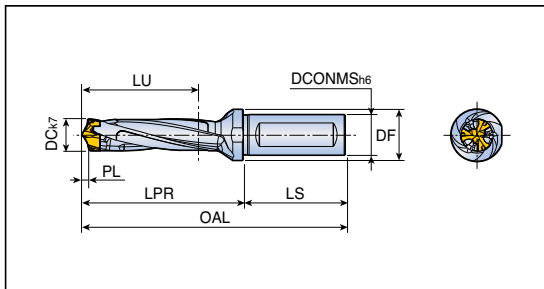

• Глубина сверления: 3xD



Обозначение	Размеры (мм)								Ключ
	DC	DCONMS	DF	LU	LPR	LS	PL	SSC	
3ED 160-169-20T3-3D	16.0-16.9	20	25	52	79.0	50	3.70	16	K 3ED D16-D17
170-179-20T3-3D	17.0-17.9	20	25	55	84.0	50	3.88	17	K 3ED D16-D17
180-189-25T2-3D	18.0-18.9	25	32	58	90.1	56	4.07	18	K 3ED D18-D19
190-199-25T2-3D	19.0-19.9	25	32	61	94.7	56	4.26	19	K 3ED D18-D19
200-209-25T2-3D	20.0-20.9	25	32	64	99.3	56	4.44	20	K 3ED D20-D21



- OAL = LPR+LS
- SSC : Размер кармана

3ED...T...-5D

Трехперое сверло со сменными головками с хвостовиком Weldon

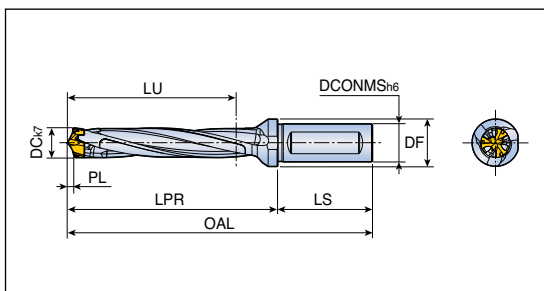

• Глубина сверления: 5xD



Обозначение	Размеры (мм)								Ключ
	DC	DCONMS	DF	LU	LPR	LS	PL	SSC	
3ED 160-169-20T3-5D	16.0-16.9	20	25	84	111.0	50	3.70	16	K 3ED D16-D17
170-179-20T3-5D	17.0-17.9	20	25	89	118.0	50	3.88	17	K 3ED D16-D17
180-189-25T2-5D	18.0-18.9	25	32	94	126.1	56	4.07	18	K 3ED D18-D19
190-199-25T2-5D	19.0-19.9	25	32	99	132.7	56	4.26	19	K 3ED D18-D19
200-209-25T2-5D	20.0-20.9	25	32	104	139.3	56	4.44	20	K 3ED D20-D21



- OAL = LPR+LS
- SSC : Размер кармана

3ED...T0...-3D

DRILLSPEED

Трехперое сверло со сменными головками с цилиндрическим хвостовиком



• Глубина сверления: 3xD

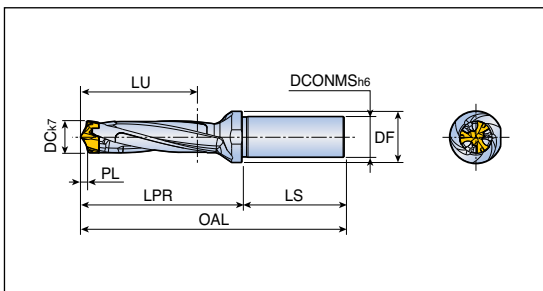

Обозначение	Размеры (мм)								Ключ
	DC	DCONMS	DF	LU	LPR	LS	PL	SSC	
3ED 160-169-20T0-3D	16.0-16.9	20	25	52	79.0	50	3.70	16	K 3ED D16-D17
170-179-20T0-3D	17.0-17.9	20	25	55	84.0	50	3.88	17	K 3ED D16-D17
180-189-25T0-3D	18.0-18.9	25	32	58	90.1	56	4.07	18	K 3ED D18-D19
190-199-25T0-3D	19.0-19.9	25	32	61	94.7	56	4.26	19	K 3ED D18-D19
200-209-25T0-3D	20.0-20.9	25	32	64	99.3	56	4.44	20	K 3ED D20-D21



- OAL = LPR+LS
- SSC : Размер кармана

3ED...T0...-5D

DRILLSPEED

Трехперое сверло со сменными головками с цилиндрическим хвостовиком



• Глубина сверления: 5xD

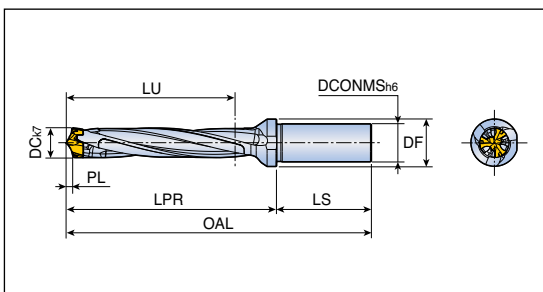

Обозначение	Размеры (мм)								Ключ
	DC	DCONMS	DF	LU	LPR	LS	PL	SSC	
3ED 160-169-20T0-5D	16.0-16.9	20	25	84	111.0	50	3.70	16	K 3ED D16-D17
170-179-20T0-5D	17.0-17.9	20	25	89	118.0	50	3.88	17	K 3ED D16-D17
180-189-25T0-5D	18.0-18.9	25	32	94	126.1	56	4.07	18	K 3ED D18-D19
190-199-25T0-5D	19.0-19.9	25	32	99	132.7	56	4.26	19	K 3ED D18-D19
200-209-25T0-5D	20.0-20.9	25	32	104	139.3	56	4.44	20	K 3ED D20-D21



- OAL = LPR+LS
- SSC : Размер кармана

TCD...T...-1.5D

Сверло со сменными головками с хвостовиком Weldon



• Глубина сверления: 1.5xD

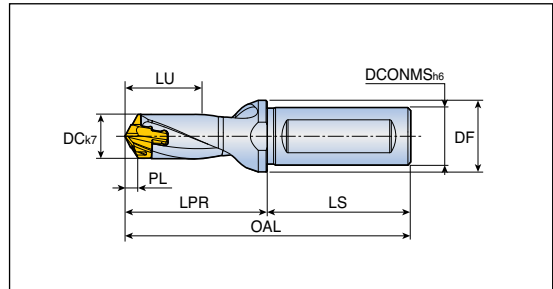

Обозначение	Размеры (мм)								Ключ	
	DC	DCONMS	DF	LU	LPR	LS	PL	SSC		
TCD 060-064-12T3-1.5D	6.0-6.4	12	16	10	23.0	45	0.96	6	K TCD D060-D099	
065-069-12T3-1.5D	6.5-6.9	12	16	11	24.1	45	1.18	6.5		
070-074-12T3-1.5D	7.0-7.4	12	16	12	25.1	45	1.01	7		
075-079-12T3-1.5D	7.5-7.9	12	16	12	25.9	45	1.10	7		
080-089-12T3-1.5D	8.0-8.9	12	16	13	27.4	45	1.20	8		
090-099-12T3-1.5D	9.0-9.9	12	16	15	29.3	45	1.35	9		
100-109-16T3-1.5D	10.0-10.9	16	20	17	31.2	48	1.50	10		K TCD D100-D199
110-119-16T3-1.5D	11.0-11.9	16	20	19	33.1	48	1.67	11		
120-129-16T3-1.5D	12.0-12.9	16	20	20	35.0	48	1.82	12		
130-139-16T3-1.5D	13.0-13.9	16	20	22	37.1	48	1.96	13		
140-149-16T3-1.5D	14.0-14.9	16	20	23	41.1	48	2.12	14		
150-159-20T3-1.5D	15.0-15.9	20	25	25	46.2	50	2.27	15		
160-169-20T3-1.5D	16.0-16.9	20	25	26	49.3	50	2.42	16		
170-179-20T3-1.5D	17.0-17.9	20	25	29	52.4	50	2.59	17		
180-189-25T2-1.5D	18.0-18.9	25	32	30	55.5	56	2.73	18		
190-199-25T2-1.5D	19.0-19.9	25	32	32	58.5	56	2.88	19	K TCD D200-D269	
200-209-25T2-1.5D	20.0-20.9	25	32	33	61.6	56	3.02	20		
210-219-25T2-1.5D	21.0-21.9	25	32	35	64.7	56	3.18	21		
220-229-25T2-1.5D	22.0-22.9	25	32	36	67.8	56	3.24	22		
230-239-32T2-1.5D	23.0-23.9	32	42	38	70.8	60	3.46	23		
240-249-32T2-1.5D	24.0-24.9	32	42	40	73.9	60	3.62	24		
250-259-32T2-1.5D	25.0-25.9	32	42	42	77.0	60	3.80	25		



- OAL = LPR+LS
- SSC : Размер кармана

TCD...S0-1.5D

Сверло со сменными головками с цилиндрическим хвостовиком



• Глубина сверления: 1.5xD

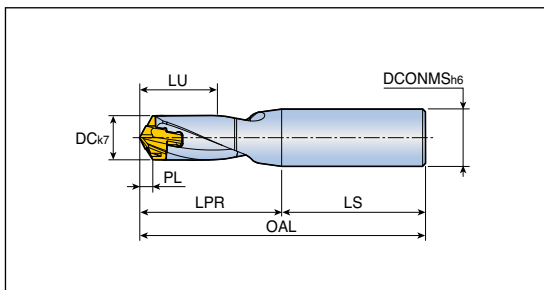

Обозначение	Размеры (мм)							Ключ
	DC	DCONMS	LU	LPR	LS	PL	SSC	
TCD 060-064-12S0-1.5D	6.0-6.4	12	10	23.0	45	0.96	6	К TCD D060-D099
065-069-12S0-1.5D	6.5-6.9	12	11	24.1	45	1.18	6.5	
070-074-12S0-1.5D	7.0-7.4	12	12	25.1	45	1.01	7	
075-079-12S0-1.5D	7.5-7.9	12	12	25.9	45	1.10	7	
080-089-12S0-1.5D	8.0-8.9	12	13	27.4	45	1.20	8	
090-099-12S0-1.5D	9.0-9.9	12	15	29.3	45	1.35	9	
100-109-16S0-1.5D	10.0-10.9	16	17	31.2	48	1.50	10	
110-119-16S0-1.5D	11.0-11.9	16	19	33.1	48	1.67	11	
120-129-16S0-1.5D	12.0-12.9	16	20	35.0	48	1.82	12	
130-139-16S0-1.5D	13.0-13.9	16	22	37.1	48	1.96	13	
140-149-16S0-1.5D	14.0-14.9	16	23	41.1	48	2.12	14	
150-159-20S0-1.5D	15.0-15.9	20	25	46.2	50	2.27	15	
160-169-20S0-1.5D	16.0-16.9	20	26	49.3	50	2.42	16	
170-179-20S0-1.5D	17.0-17.9	20	29	52.4	50	2.59	17	К TCD D200-D269
180-189-25S0-1.5D	18.0-18.9	25	30	55.5	56	2.73	18	
190-199-25S0-1.5D	19.0-19.9	25	32	58.5	56	2.88	19	
200-209-25S0-1.5D	20.0-20.9	25	33	61.6	56	3.02	20	
210-219-25S0-1.5D	21.0-21.9	25	35	64.7	56	3.18	21	
220-229-25S0-1.5D	22.0-22.9	25	36	67.8	56	3.24	22	
230-239-32S0-1.5D	23.0-23.9	32	38	70.8	60	3.46	23	
240-249-32S0-1.5D	24.0-24.9	32	40	73.9	60	3.62	24	
250-259-32S0-1.5D	25.0-25.9	32	42	77.0	60	3.80	25	



- OAL = LPR+LS
- SSC : Размер кармана

TCD...T...-3D

Сверло со сменными головками с хвостовиком Weldon

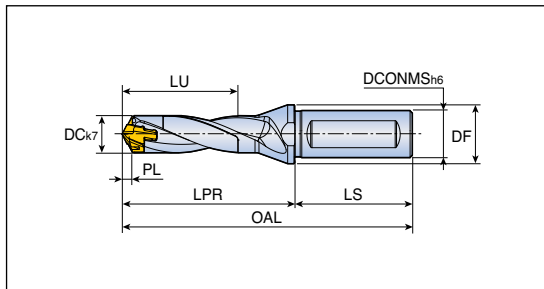

• Глубина сверления: 3xD



Обозначение	Размеры (мм)								Ключ	
	DC	DCONMS	DF	LU	LPR	LS	PL	SSC		
TCD 060-064-12T3-3D	6.0-6.4	12	16	19	32.0	45	0.96	6	K TCD D060-D099	
065-069-12T3-3D	6.5-6.9	12	16	21	33.8	45	1.18	6.5		
070-074-12T3-3D	7.0-7.4	12	16	22	35.6	45	1.01	7		
075-079-12T3-3D	7.5-7.9	12	16	24	37.1	45	1.10	7		
080-084-12T3-3D	8.0-8.4	12	16	25	39.4	45	1.20	8		
085-089-12T3-3D	8.5-8.9	12	16	27	40.9	45	1.29	8		
090-094-12T3-3D	9.0-9.4	12	16	28	42.8	45	1.35	9		
095-099-12T3-3D	9.5-9.9	12	16	30	44.3	45	1.44	9		
100-104-16T3-3D	10.0-10.4	16	20	32	46.2	48	1.50	10		K TCD D100-D199
105-109-16T3-3D	10.5-10.9	16	20	34	47.7	48	1.59	10		
110-114-16T3-3D	11.0-11.4	16	20	35	49.6	48	1.67	11		
115-119-16T3-3D	11.5-11.9	16	20	37	51.1	48	1.76	11		
120-124-16T3-3D	12.0-12.4	16	20	38	53.0	48	1.82	12		
125-129-16T3-3D	12.5-12.9	16	20	39	54.5	48	1.91	12		
130-134-16T3-3D	13.0-13.4	16	20	41	56.6	48	1.96	13		
135-139-16T3-3D	13.5-13.9	16	20	43	58.1	48	2.05	13		
140-144-16T3-3D	14.0-14.4	16	20	44	62.2	48	2.12	14		
145-149-16T3-3D	14.5-14.9	16	20	46	63.7	48	2.21	14		
150-159-20T3-3D	15.0-15.9	20	25	47	68.7	50	2.27	15	K TCD D200-D269	
160-169-20T3-3D	16.0-16.9	20	25	50	73.3	50	2.42	16		
170-179-20T3-3D	17.0-17.9	20	25	54	77.9	50	2.59	17		
180-189-25T2-3D	18.0-18.9	25	32	57	82.5	56	2.73	18		
190-199-25T2-3D	19.0-19.9	25	32	60	87.0	56	2.88	19		
200-209-25T2-3D	20.0-20.9	25	32	63	91.6	56	3.02	20		
210-219-25T2-3D	21.0-21.9	25	32	66	96.2	56	3.18	21		
220-229-25T2-3D	22.0-22.9	25	32	69	100.8	56	3.24	22		
230-239-32T2-3D	23.0-23.9	32	42	72	105.3	60	3.46	23		
240-249-32T2-3D	24.0-24.9	32	42	76	109.9	60	3.62	24		
250-259-32T2-3D	25.0-25.9	32	42	79	114.5	60	3.80	25		



- OAL = LPR+LS
- SSC : Размер кармана

Сверло со сменными головками с цилиндрическим хвостовиком



• Глубина сверления: 3xD

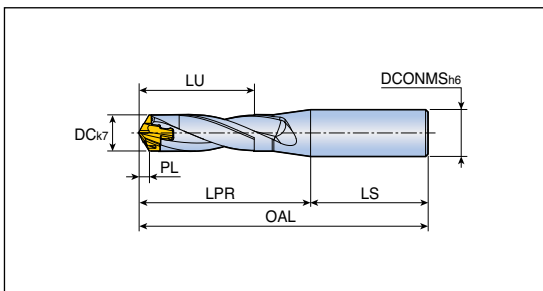

Обозначение	Размеры (мм)							Ключ
	DC	DCONMS	LU	LPR	LS	PL	SSC	
TCD 060-064-12S0-3D	6.0-6.4	12	19	32.0	45	0.96	6	K TCD D060-D099
065-069-12S0-3D	6.5-6.9	12	21	33.8	45	1.18	6.5	
070-074-12S0-3D	7.0-7.4	12	22	35.6	45	1.01	7	
075-079-12S0-3D	7.5-7.9	12	24	37.1	45	1.10	7	
080-084-12S0-3D	8.0-8.4	12	25	39.4	45	1.20	8	
085-089-12S0-3D	8.5-8.9	12	27	40.9	45	1.29	8	
090-094-12S0-3D	9.0-9.4	12	28	42.8	45	1.35	9	
095-099-12S0-3D	9.5-9.9	12	30	44.3	45	1.44	9	
100-104-16S0-3D	10.0-10.4	16	32	46.2	48	1.50	10	
105-109-16S0-3D	10.5-10.9	16	34	47.7	48	1.59	10	
110-114-16S0-3D	11.0-11.4	16	35	49.6	48	1.67	11	
115-119-16S0-3D	11.5-11.9	16	37	51.1	48	1.76	11	
120-124-16S0-3D	12.0-12.4	16	38	53.0	48	1.82	12	
125-129-16S0-3D	12.5-12.9	16	39	54.5	48	1.91	12	
130-134-16S0-3D	13.0-13.4	16	41	56.6	48	1.96	13	
135-139-16S0-3D	13.5-13.9	16	43	58.1	48	2.05	13	
140-144-16S0-3D	14.0-14.4	16	44	62.1	48	2.12	14	
145-149-16S0-3D	14.5-14.9	16	46	63.7	48	2.21	14	
150-159-20S0-3D	15.0-15.9	20	47	68.7	50	2.27	15	K TCD D200-D269
160-169-20S0-3D	16.0-16.9	20	50	73.3	50	2.42	16	
170-179-20S0-3D	17.0-17.9	20	54	77.9	50	2.59	17	
180-189-25S0-3D	18.0-18.9	25	57	82.5	56	2.73	18	
190-199-25S0-3D	19.0-19.9	25	60	87.0	56	2.88	19	
200-209-25S0-3D	20.0-20.9	25	63	91.6	56	3.02	20	
210-219-25S0-3D	21.0-21.9	25	66	96.2	56	3.18	21	
220-229-25S0-3D	22.0-22.9	25	69	100.8	56	3.24	22	
230-239-32S0-3D	23.0-23.9	32	72	105.3	60	3.46	23	
240-249-32S0-3D	24.0-24.9	32	76	109.9	60	3.62	24	
250-259-32S0-3D	25.0-25.9	32	79	114.5	60	3.80	25	



- OAL = LPR+LS
- SSC : Размер кармана

TCD...T...-5D

Сверло со сменными головками с хвостовиком Weldon

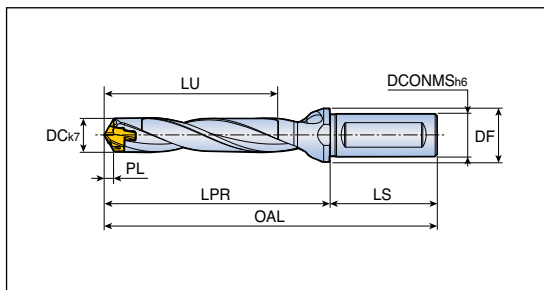

• Глубина сверления: 5xD



Обозначение	Размеры (мм)								Ключ	
	DC	DCONMS	DF	LU	LPR	LS	PL	SSC		
TCD 060-064-12T3-5D	6.0-6.4	12	16	31	44.0	45	0.96	6	K TCD D060-D099	
065-069-12T3-5D	6.5-6.9	12	16	34	46.8	45	1.18	6.5		
070-074-12T3-5D	7.0-7.4	12	16	36	49.6	45	1.01	7		
075-079-12T3-5D	7.5-7.9	12	16	39	52.1	45	1.10	7		
080-084-12T3-5D	8.0-8.4	12	16	41	55.4	45	1.20	8		
085-089-12T3-5D	8.5-8.9	12	16	44	57.9	45	1.29	8		
090-094-12T3-5D	9.0-9.4	12	16	46	60.8	45	1.35	9		
095-099-12T3-5D	9.5-9.9	12	16	49	63.3	45	1.44	9		
100-104-16T3-5D	10.0-10.4	16	20	52	66.2	48	1.50	10		K TCD D100-D199
105-109-16T3-5D	10.5-10.9	16	20	55	68.7	48	1.59	10		
110-114-16T3-5D	11.0-11.4	16	20	57	71.6	48	1.67	11		
115-119-16T3-5D	11.5-11.9	16	20	60	74.1	48	1.76	11		
120-124-16T3-5D	12.0-12.4	16	20	62	77.0	48	1.82	12		
125-129-16T3-5D	12.5-12.9	16	20	64	79.5	48	1.91	12		
130-134-16T3-5D	13.0-13.4	16	20	67	82.6	48	1.96	13		
135-139-16T3-5D	13.5-13.9	16	20	70	85.1	48	2.05	13		
140-144-16T3-5D	14.0-14.4	16	20	72	90.2	48	2.12	14		
145-149-16T3-5D	14.5-14.9	16	20	75	92.7	48	2.21	14		
150-159-20T3-5D	15.0-15.9	20	25	77	98.7	50	2.27	15	K TCD D200-D269	
160-169-20T3-5D	16.0-16.9	20	25	82	105.3	50	2.42	16		
170-179-20T3-5D	17.0-17.9	20	25	88	111.9	50	2.59	17		
180-189-25T2-5D	18.0-18.9	25	32	93	118.5	56	2.73	18		
190-199-25T2-5D	19.0-19.9	25	32	98	125.0	56	2.88	19		
200-209-25T2-5D	20.0-20.9	25	32	103	131.6	56	3.02	20		
210-219-25T2-5D	21.0-21.9	25	32	108	138.2	56	3.18	21		
220-229-25T2-5D	22.0-22.9	25	32	113	144.8	56	3.24	22		
230-239-32T2-5D	23.0-23.9	32	42	118	151.3	60	3.46	23		
240-249-32T2-5D	24.0-24.9	32	42	124	157.9	60	3.62	24		
250-259-32T2-5D	25.0-25.9	32	42	129	164.5	60	3.80	25		



- OAL = LPR+LS
- SSC : Размер кармана

Сверло со сменными головками с цилиндрическим хвостовиком



• Глубина сверления: 5xD

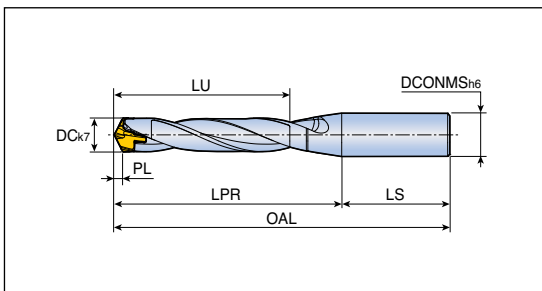

Обозначение	Размеры (мм)							Ключ	
	DC	DCONMS	LU	LPR	LS	PL	SSC		
TCD 060-064-12S0-5D	6.0-6.4	12	31	44.0	45	0.96	6	K TCD D060-D099	
065-069-12S0-5D	6.5-6.9	12	34	46.8	45	1.18	6.5		
070-074-12S0-5D	7.0-7.4	12	36	49.6	45	1.01	7		
075-079-12S0-5D	7.5-7.9	12	39	52.1	45	1.10	7		
080-084-12S0-5D	8.0-8.4	12	41	55.4	45	1.20	8		
085-089-12S0-5D	8.5-8.9	12	44	57.9	45	1.29	8		
090-094-12S0-5D	9.0-9.4	12	46	60.8	45	1.35	9		
095-099-12S0-5D	9.5-9.9	12	49	63.3	45	1.44	9		
100-104-16S0-5D	10.0-10.4	16	52	66.2	48	1.50	10		K TCD D100-D199
105-109-16S0-5D	10.5-10.9	16	55	68.7	48	1.59	10		
110-114-16S0-5D	11.0-11.4	16	57	71.6	48	1.67	11		
115-119-16S0-5D	11.5-11.9	16	60	74.1	48	1.76	11		
120-124-16S0-5D	12.0-12.4	16	62	77.0	48	1.82	12		
125-129-16S0-5D	12.5-12.9	16	64	79.5	48	1.91	12		
130-134-16S0-5D	13.0-13.4	16	67	82.6	48	1.96	13		
135-139-16S0-5D	13.5-13.9	16	70	85.1	48	2.05	13		
140-144-16S0-5D	14.0-14.4	16	72	90.2	48	2.12	14		
145-149-16S0-5D	14.5-14.9	16	75	92.7	48	2.21	14		
150-159-20S0-5D	15.0-15.9	20	77	98.7	50	2.27	15	K TCD D200-D269	
160-169-20S0-5D	16.0-16.9	20	82	105.3	50	2.42	16		
170-179-20S0-5D	17.0-17.9	20	88	111.9	50	2.59	17		
180-189-25S0-5D	18.0-18.9	25	93	118.5	56	2.73	18		
190-199-25S0-5D	19.0-19.9	25	98	125.0	56	2.88	19		
200-209-25S0-5D	20.0-20.9	25	103	131.6	56	3.02	20		
210-219-25S0-5D	21.0-21.9	25	108	138.2	56	3.18	21		
220-229-25S0-5D	22.0-22.9	25	113	144.8	56	3.24	22		
230-239-32S0-5D	23.0-23.9	32	118	151.3	60	3.46	23		
240-249-32S0-5D	24.0-24.9	32	124	157.9	60	3.62	24		
250-259-32S0-5D	25.0-25.9	32	129	164.5	60	3.80	25		



- OAL = LPR+LS
- SSC : Размер кармана

Сверло со сменными головками с хвостовиком Weldon



• Глубина сверления: 8xD

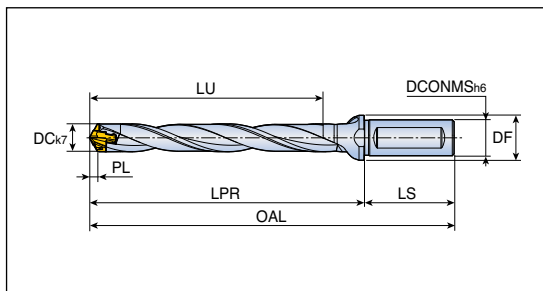

Обозначение	Размеры (мм)								Ключ
	DC	DCONMS	DF	LU	LPR	LS	PL	SSC	
TCD 070-074-12T3-8D	7.0-7.4	12	16	57	70.6	45	1.01	7	K TCD D060-D099
075-079-12T3-8D	7.5-7.9	12	16	61	74.6	45	1.10	7	
080-084-12T3-8D	8.0-8.4	12	16	65	79.4	45	1.20	8	
085-089-12T3-8D	8.5-8.9	12	16	69	83.4	45	1.29	8	
090-094-12T3-8D	9.0-9.4	12	16	73	87.8	45	1.35	9	
095-099-12T3-8D	9.5-9.9	12	16	77	91.8	45	1.44	9	
100-104-16T3-8D	10.0-10.4	16	20	82	96.2	48	1.50	10	K TCD D100-D199
105-109-16T3-8D	10.5-10.9	16	20	86	100.2	48	1.59	10	
110-114-16T3-8D	11.0-11.4	16	20	90	104.6	48	1.67	11	
115-119-16T3-8D	11.5-11.9	16	20	94	108.6	48	1.76	11	
120-124-16T3-8D	12.0-12.4	16	20	98	113.0	48	1.82	12	
125-129-16T3-8D	12.5-12.9	16	20	102	117.0	48	1.91	12	
130-134-16T3-8D	13.0-13.4	16	20	106	121.6	48	1.96	13	
135-139-16T3-8D	13.5-13.9	16	20	110	125.6	48	2.05	13	
140-144-16T3-8D	14.0-14.4	16	20	114	132.2	48	2.12	14	
145-149-16T3-8D	14.5-14.9	16	20	118	136.2	48	2.21	14	
150-159-20T3-8D	15.0-15.9	20	25	122	143.7	50	2.27	15	K TCD D200-D269
160-169-20T3-8D	16.0-16.9	20	25	130	153.3	50	2.42	16	
170-179-20T3-8D	17.0-17.9	20	25	139	162.9	50	2.59	17	
180-189-25T2-8D	18.0-18.9	25	32	147	172.5	56	2.73	18	
190-199-25T2-8D	19.0-19.9	25	32	155	182.0	56	2.88	19	
200-209-25T2-8D	20.0-20.9	25	32	163	191.6	56	3.02	20	
210-219-25T2-8D	21.0-21.9	25	32	171	201.2	56	3.18	21	
220-229-25T2-8D	22.0-22.9	25	32	179	210.8	56	3.24	22	
230-239-32T2-8D	23.0-23.9	32	42	187	220.3	60	3.46	23	
240-249-32T2-8D	24.0-24.9	32	42	196	229.9	60	3.62	24	
250-259-32T2-8D	25.0-25.9	32	42	204	239.5	60	3.80	25	



- Рекомендуется выполнять пилотное отверстие корпусом сверла 1.5D
- OAL = LPR+LS
- SSC : Размер кармана

Сверло со сменными головками с цилиндрическим хвостовиком



• Глубина сверления: 8xD

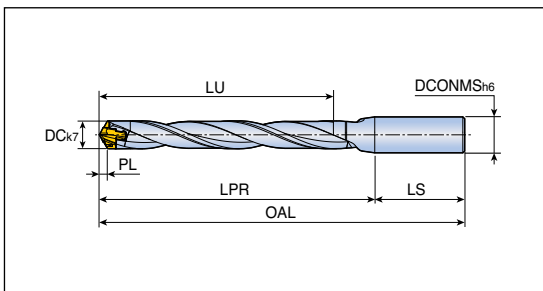

Обозначение	Размеры (мм)							Ключ
	DC	DCONMS	LU	LPR	LS	PL	SSC	
TCD 070-074-12S0-8D	7.0-7.4	12	57	70.6	45	1.01	7	K TCD D060-D099
075-079-12S0-8D	7.5-7.9	12	61	74.6	45	1.10	7	
080-084-12S0-8D	8.0-8.4	12	65	79.4	45	1.20	8	
085-089-12S0-8D	8.5-8.9	12	69	83.4	45	1.29	8	
090-094-12S0-8D	9.0-9.4	12	73	91.8	45	1.35	9	
095-099-12S0-8D	9.5-9.9	12	77	92.7	45	1.44	9	
100-104-16S0-8D	10.0-10.4	16	82	96.2	48	1.50	10	K TCD D100-D199
105-109-16S0-8D	10.5-10.9	16	86	100.2	48	1.59	10	
110-114-16S0-8D	11.0-11.4	16	90	104.6	48	1.67	11	
115-119-16S0-8D	11.5-11.9	16	94	108.6	48	1.76	11	
120-124-16S0-8D	12.0-12.4	16	98	113.0	48	1.82	12	
125-129-16S0-8D	12.5-12.9	16	102	117.0	48	1.91	12	
130-134-16S0-8D	13.0-13.4	16	106	121.6	48	1.96	13	
135-139-16S0-8D	13.5-13.9	16	110	125.6	48	2.05	13	
140-144-16S0-8D	14.0-14.4	16	114	132.2	48	2.12	14	
145-149-16S0-8D	14.5-14.9	16	118	136.2	48	2.21	14	
150-159-20S0-8D	15.0-15.9	20	122	143.7	50	2.27	15	K TCD D200-D269
160-169-20S0-8D	16.0-16.9	20	130	153.3	50	2.42	16	
170-179-20S0-8D	17.0-17.9	20	139	162.9	50	2.59	17	
180-189-25S0-8D	18.0-18.9	25	147	172.5	56	2.73	18	
190-199-25S0-8D	19.0-19.9	25	155	182.0	56	2.88	19	
200-209-25S0-8D	20.0-20.9	25	163	191.6	56	3.02	20	
210-219-25S0-8D	21.0-21.9	25	171	201.2	56	3.18	21	
220-229-25S0-8D	22.0-22.9	25	179	210.8	56	3.24	22	
230-239-32S0-8D	23.0-23.9	32	187	220.3	60	3.46	23	
240-249-32S0-8D	24.0-24.9	32	196	229.9	60	3.62	24	
250-259-32S0-8D	25.0-25.9	32	204	239.5	60	3.80	25	



- Рекомендуется выполнять пилотное отверстие корпусом сверла 1.5D
- OAL = LPR+LS
- SSC : Размер кармана

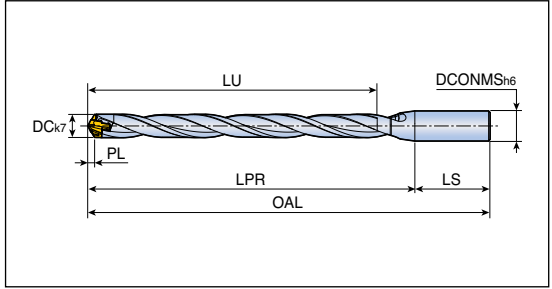

• Глубина сверления: 12xD



Обозначение	Размеры (мм)							Ключ
	DC	DCONMS	LU	LPR	LS	PL	SSC	
TCD 080-084-12S0-12D	8.0-8.4	12	97	111.4	45	1.20	8	K TCD D060-D099
085-089-12S0-12D	8.5-8.9	12	103	117.4	45	1.29	8	
090-094-12S0-12D	9.0-9.4	12	109	123.8	45	1.35	9	
095-099-12S0-12D	9.5-9.9	12	115	129.8	45	1.44	9	
100-104-16S0-12D	10.0-10.4	16	122	136.2	48	1.50	10	
105-109-16S0-12D	10.5-10.9	16	128	142.2	48	1.59	10	
110-114-16S0-12D	11.0-11.4	16	134	148.6	48	1.67	11	
115-119-16S0-12D	11.5-11.9	16	140	154.6	48	1.76	11	
120-124-16S0-12D	12.0-12.4	16	146	161.0	48	1.82	12	
125-129-16S0-12D	12.5-12.9	16	152	167.0	48	1.91	12	
130-134-16S0-12D	13.0-13.4	16	158	173.6	48	1.96	13	
135-139-16S0-12D	13.5-13.9	16	164	179.6	48	2.05	13	
140-144-16S0-12D	14.0-14.4	16	170	188.2	48	2.12	14	
145-149-16S0-12D	14.5-14.9	16	176	194.2	48	2.21	14	
150-159-20S0-12D	15.0-15.9	20	182	203.7	50	2.27	15	
160-169-20S0-12D	16.0-16.9	20	194	217.3	50	2.42	16	
170-179-20S0-12D	17.0-17.9	20	207	230.9	50	2.59	17	
180-189-25S0-12D	18.0-18.9	25	219	244.5	56	2.73	18	
190-199-25S0-12D	19.0-19.9	25	221	258.0	56	2.88	19	
200-209-25S0-12D	20.0-20.9	25	243	271.6	56	3.02	20	K TCD D200-D269
210-219-25S0-12D	21.0-21.9	25	255	285.2	56	3.18	21	
220-229-25S0-12D	22.0-22.9	25	267	298.8	56	3.24	22	
230-239-32S0-12D	23.0-23.9	32	289	312.3	60	3.46	23	
240-249-32S0-12D	24.0-24.9	32	292	325.9	60	3.62	24	
250-259-32S0-12D	25.0-25.9	32	304	339.5	60	3.80	25	



- Рекомендуется выполнять пилотное отверстие корпусом сверла 1.5D
- OAL = LPR+LS
- SSC : Размер кармана

Сверло со сменными головками для отверстий под резьбу

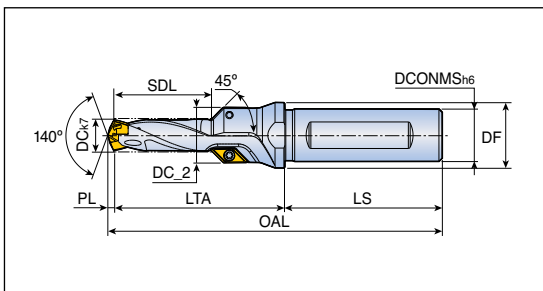

Обозначение	ISO резьба	DC	Размеры (мм)							Диапазон диаметров	Пластина
			SDL	LTA	LS	DC_2	DCONMS	DF	PL		
TCD 068x21x12T3-M8	M8	6.8	21	43.77	45	13.5	12	16	1.23	6.5-6.9	AOMT 06...-C45 D162
085x26x12T3-M10	M10	8.5	26	48.71	45	15.5	12	16	1.29	8.5-8.9	
102x30x16T3-M12	M12	10.2	30	52.46	48	17.0	16	20	1.54	10.0-10.4	
120x35x16T3-M14	M14	12.0	35	59.18	48	19.0	16	20	1.82	12.0-12.4	
140x39x20T3-M16	M16	14.0	39	66.88	50	21.0	20	25	2.12	14.0-14.4	
175x42x20T3-M20	M20	17.5	42	69.32	50	24.5	20	27	2.68	17.0-17.9	
210x48x25T2-M24	M24	21.0	48	76.82	56	28.0	25	32	3.18	21.0-21.9	

• OAL = LTA+LS+PL

Комплектующие

Обозначение	Винт	Ключ	Фиксирующий ключ	
TCD 068	TS 22046I	TD 7	K TCD D060-D099	
TCD 085	TS 22046I	TD 7	K TCD D060-D099	
TCD 102 - 175	TS 22046I	TD 7	K TCD D100-D199	
TCD 210	TS 22046I	TD 7	K TCD D200-D269	



Заглушка для канала подачи СОЖ на стационарных станках

ТаегуТес поставляет специальные заглушки с внутренней резьбой для соединений с каналами подачи СОЖ на токарных станках, которые можно вдавливать в полость задней части хвостовика.

Обозначение	Диаметр хвостовика	Внутренняя резьба
PL-TCD-12	12	G 1/16
PL-TCD-16	16	G 1/16
PL-TCD-20	20	G 1/8
PL-TCD-25	25	G 1/8
PL-TCD-32	32	G 1/8



Насадка для обработки фаски

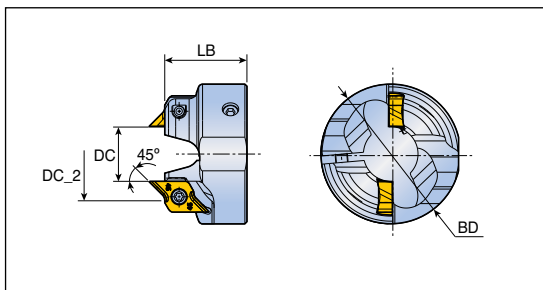

Обозначение	Размеры (мм)				Размер фаски	Режущая пластина
	DC	DC_2	BD	LB		
CFR D100-A45	9.8	16.56	34	20	2.5	CRNG 08...-45CD D162
D105-A45	10.3	17.06	34	20	2.5	
D110-A45	10.8	17.56	34	20	2.5	
D115-A45	11.3	18.06	34	20	2.5	
D120-A45	11.8	18.56	34	20	2.5	
D125-A45	12.3	19.06	34	20	2.5	
D130-A45	12.8	19.56	34	20	2.5	
D135-A45	13.3	20.06	34	20	2.5	
D140-A45	13.8	20.56	38	22	2.5	
D145-A45	14.3	21.06	38	22	2.5	
D150-A45	14.6	21.36	38	22	2.5	
D160-A45	15.6	22.36	42	23	2.5	
D170-A45	16.6	23.36	42	23	2.5	
D180-A45	17.6	24.36	42	23	2.5	
D190-A45	18.6	25.36	42	24	2.5	
D200-A45	19.6	26.36	42	24	2.5	
D210-A45	20.6	27.36	47	24	2.5	
D220-A45	21.6	28.36	47	24	2.5	
D230-A45	22.6	29.36	47	24	2.5	
D240-A45	23.6	30.36	47	24	2.5	
D250-A45	24.6	31.36	47	24	2.5	

Комплектующие

Обозначение	Винт пластины	Ключ	Зажимной винт	Ключ
CFR D100 - D135	SO 25065I	TD 7	SH M3x0.5x10 ⁽¹⁾	L-W2.5
CFR D140 - D150	SO 25065I	TD 7	SH M4x0.7x12 ⁽²⁾	L-W3
CFR D160 - D250	SO 25065I	TD 7	SH M5x0.8x16 ⁽³⁾	L-W4



- ⁽¹⁾ Момент затяжки 2-3 [Н/м] ⁽²⁾ Момент затяжки: 3,5-4,5 [Н/м] ⁽³⁾ Момент затяжки: 5-6 [Н/м]

Модульная сверлильная головка

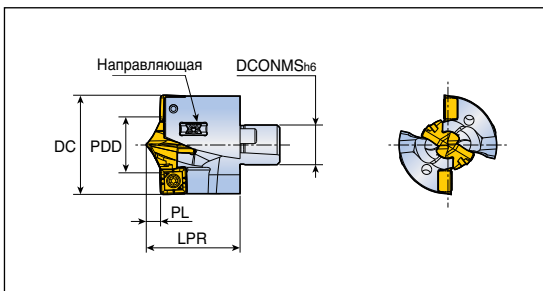

Обозначение	Размеры (мм)					Ключ	Пластина	
	DC	DCONMS	LPR	PL	PDD		Центральная	Наружная
TNDH 2600-C26-TP	26	10.4	24.9	3.98	15.9	K TCD D15-CO	TCD-159-P-CO+	SPGX 06...DW
2700-C26-TP	27	10.4	25.4	4.14	16.9	K TCD D16-CO	TCD-169-P-CO+	SPGX 06...DW
2800-C28-TP	28	11.2	26.9	4.29	17.9	K TCD D17-CO	TCD-179-P-CO+	SPGX 06...DW
2900-C28-TP	29	11.2	26.6	3.97	15.9	K TCD D15-CO	TCD-159-P-CO+	SPGX 07...DW
3000-C30-TP	30	12.0	28.3	4.14	16.9	K TCD D16-CO	TCD-169-P-CO+	SPGX 07...DW
3100-C30-TP	31	12.0	28.5	4.30	17.9	K TCD D17-CO	TCD-179-P-CO+	SPGX 07...DW
3200-C32-TP	32	12.8	30.3	4.46	18.9	K TCD D18-CO	TCD-189-P-CO+	SPGX 07...DW
3300-C32-TP	33	12.8	29.8	3.97	15.9	K TCD D15-CO	TCD-159-P-CO+	SPGX 09...DW
3400-C34-TP	34	13.6	31.6	4.14	16.9	K TCD D16-CO	TCD-169-P-CO+	SPGX 09...DW
3500-C34-TP	35	13.6	31.8	4.30	17.9	K TCD D17-CO	TCD-179-P-CO+	SPGX 09...DW
3600-C36-TP	36	14.4	33.5	4.46	18.9	K TCD D18-CO	TCD-189-P-CO+	SPGX 09...DW
3700-C36-TP	37	14.4	33.3	4.14	16.9	K TCD D16-CO	TCD-169-P-CO+	SPGX 11...DW
3800-C38-TP	38	15.2	35.0	4.30	17.9	K TCD D17-CO	TCD-179-P-CO+	SPGX 11...DW
3900-C38-TP	39	15.2	35.2	4.46	18.9	K TCD D18-CO	TCD-189-P-CO+	SPGX 11...DW
4000-C40-TP	40	16.0	36.9	4.62	19.9	K TCD D19-CO	TCD-199-P-CO+	SPGX 11...DW
4100-C40-TP	41	16.0	37.1	4.78	20.9	K TCD D20-CO	TCD-209-P-CO+	SPGX 11...DW
4200-C42-TP	42	16.8	38.9	4.95	21.9	K TCD D21-CO	TCD-219-P-CO+	SPGX 11...DW
4300-C42-TP	43	16.8	38.9	5.11	22.9	K TCD D22-CO	TCD-229-P-CO+	SPGX 11...DW



- DCONMS: Посадочный размер модульной головки
- Направляющую необходимо заказывать отдельно

Комплектующие

Обозначение	Для двухшагового винта		Для SPGX		Для направляющей	
	Винт1	Ключ1	Винт2	Ключ2	Винт3	Ключ3
TNDH 2600-2800	TDPS 0512-W2.0	F-W2.0	TS 220521/HG	TD 7	TS 200431/HG-P	TD 6P
TNDH 2900-3200	TDPS 0512-W2.0	F-W2.0	TS 250641	TD 8	TS 200431/HG-P	TD 6P
TNDH 3300-3500	TDPS 0512-W2.0	F-W2.0	TS 350881	TD 10	TS 200431/HG-P	TD 6P
TNDH 3600	TDPS 0618-W2.5	F-W2.5	TS 350881	TD 10	TS 200431/HG-P	TD 6P
TNDH 3700-4300	TDPS 0618-W2.5	F-W2.5	TS 400931	TD 15	TS 200431/HG-P	TD 6P



Модульная сверлильная головка

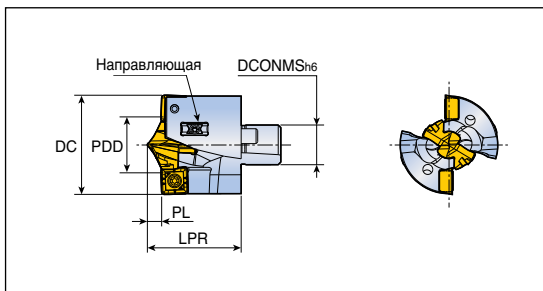

Обозначение	Размеры (мм)					Ключ	Пластина	
	DC	DCNMS	LPR	PL	PDD		Центральная	Наружная
TNDH 4400-C44-TP	44	17.6	40.8	5.28	23.9	K TCD D23-CO	TCD-239-P-CO+	SPGX 11...DW
4500-C44-TP	45	17.6	41.0	5.44	24.9	K TCD D24-CO	TCD-249-P-CO+	SPGX 11...DW
4600-C46-TP	46	18.4	42.2	4.95	21.9	K TCD D21-CO	TCD-219-P-CO+	SPGX 14...DW
4700-C46-TP	47	18.4	42.3	5.11	22.9	K TCD D22-CO	TCD-229-P-CO+	SPGX 14...DW
4800-C48-TP	48	19.2	44.0	5.28	23.9	K TCD D23-CO	TCD-239-P-CO+	SPGX 14...DW
4900-C48-TP	49	19.2	44.3	5.44	24.9	K TCD D24-CO	TCD-249-P-CO+	SPGX 14...DW
5000-C48-TP	50	19.2	46.0	5.61	25.9	K TCD D25-CO	TCD-259-P-CO+	SPGX 14...DW
								D163

- DCONMS: Посадочный размер модульной головки
- Направляющую необходимо заказывать отдельно

Комплектующие

Обозначение	Для двухшагового винта		Для SPGX		Для направляющей	
	Винт1	Ключ1	Винт2	Ключ2	Винт3	Ключ3
TNDH 4400-4500	TDPS 0722-W3.0	F-W3.0	TS 40093I	TD 15	TS 20043I/HG-P	TD 6P
TNDH 4600-5000	TDPS 0722-W3.0	F-W3.0	SO 50090I	TD 20	TS 20043I/HG-P	TD 6P



Модульное сверло с хвостовиком Weldon



- Глубина сверления: 3xD

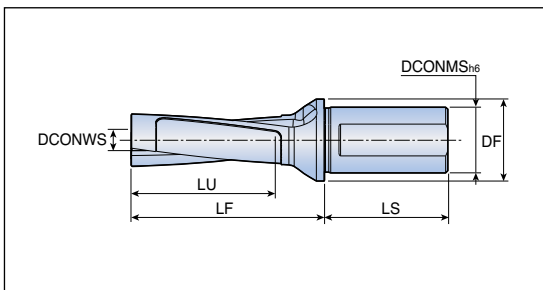

Обозначение	Размеры (мм)						
	DC	DCONWS	DCONMS	DF	LU	LF	LS
MDB D26/27-081-32T2-C26-3	26-27	10.4	32	40	60	94.3	60
D28/29-087-32T2-C28-3	28-29	11.2	32	40	64	100.5	60
D30/31-093-32T2-C30-3	30-31	12.0	32	40	69	105.5	60
D32/33-099-32T2-C32-3	32-33	12.8	32	40	73	111.7	60
D34/35-105-40T2-C34-3	34-35	13.6	40	50	78	120.2	68
D36/37-111-40T2-C36-3	36-37	14.4	40	50	82	126.5	68
D38/39-117-40T2-C38-3	38-39	15.2	40	50	86	131.4	68
D40/41-123-40T2-C40-3	40-41	16.0	40	50	91	137.6	68
D42/43-129-40T2-C42-3	42-43	16.8	40	50	95	143.8	68
D44/45-135-40T2-C44-3	44-45	17.6	40	50	99	150.0	68
D46/47-141-50T2-C46-3	46-47	18.4	50	60	104	154.5	80
D48/50-150-50T2-C48-3	48-50	19.2	50	60	111	160.9	80

- DC: Диапазон диаметров устанавливаемых головок
- DCONMS: Посадочный размер модульной головки

Комплектующие

Обозначение	Ключ	Ручонка ключа		
MDB D26/27-D34/35-3	BLD H-W2.5x210	SW6-T-SH		
MDB D36/37-D42/43-3	BLD H-W3.0x225	SW6-T-SH		
MDB D44/45-D48/50-3	BLD H-W4.0x255	SW6-T-SH		

- Открутите модульную головку от корпуса сверла с помощью ключа



Модульное сверло с хвостовиком Weldon



- Глубина сверления: 5xD

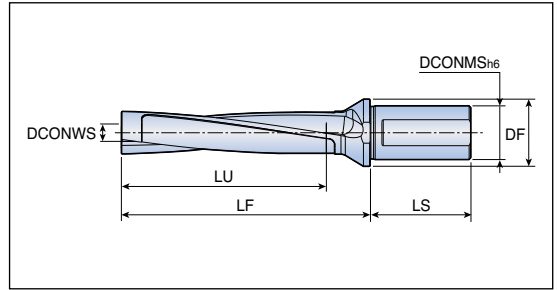

Обозначение	Размеры (мм)						
	DC	DCONWS	DCONMS	DF	LU	LF	LS
MDB D26/27-135-32T2-C26-5	26-27	10.4	32	40	114	148.3	60
D28/29-145-32T2-C28-5	28-29	11.2	32	40	122	158.5	60
D30/31-155-32T2-C30-5	30-31	12.0	32	40	131	167.5	60
D32/33-165-32T2-C32-5	32-33	12.8	32	40	139	177.7	60
D34/35-175-40T2-C34-5	34-35	13.6	40	50	148	190.2	68
D36/37-185-40T2-C36-5	36-37	14.4	40	50	156	200.5	68
D38/39-195-40T2-C38-5	38-39	15.2	40	50	164	209.4	68
D40/41-205-40T2-C40-5	40-41	16.0	40	50	173	219.6	68
D42/43-215-40T2-C42-5	42-43	16.8	40	50	181	229.8	68
D44/45-225-40T2-C44-5	44-45	17.6	40	50	189	240.0	68
D46/47-235-50T2-C46-5	46-47	18.4	50	60	198	248.5	80
D48/50-250-50T2-C48-5	48-50	19.2	50	60	211	258.9	80

- DC: Диапазон диаметров устанавливаемых головок
- DCONMS: Посадочный размер модульной головки

Комплектующие

Обозначение	Ключ	Рукоятка ключа		
MDB D26/27-D34/35-5				
MDB D36/37-D42/43-5	BLD H-W2.5x280	SW6-T-SH		
MDB D36/37-D42/43-5	BLD H-W3.0x310	SW6-T-SH		
MDB D44/45-D48/50-5	BLD H-W4.0x350	SW6-T-SH		

- Открутите модульную головку от корпуса сверла с помощью ключа



Модульное сверло с хвостовиком Weldon



• Глубина сверления: 3xD

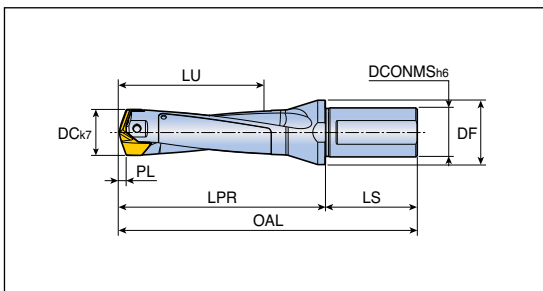

Обозначение	Размеры (мм)							
	DC	DCONMS	DF	LU	LPR	LS	PL	SSC
LCD 200-209-25T2-3D	20.0-20.9	25	32	63	92.1	56	3.11	20
210-219-25T2-3D	21.0-21.9	25	32	66	95.3	56	3.29	21
220-229-25T2-3D	22.0-22.9	25	32	69	98.4	56	3.42	22
230-239-25T2-3D	23.0-23.9	25	32	73	101.6	56	3.60	23
240-249-32T2-3D	24.0-24.9	32	40	76	110.7	60	3.73	24
250-259-32T2-3D	25.0-25.9	32	40	79	113.9	60	3.91	25
260-269-32T2-3D	26.0-26.9	32	40	82	117.0	60	4.04	26
270-279-32T2-3D	27.0-27.9	32	40	85	120.2	60	4.22	27
280-289-32T2-3D	28.0-28.9	32	40	88	128.4	60	4.35	28
290-299-32T2-3D	29.0-29.9	32	40	92	131.5	60	4.53	29
300-309-32T2-3D	30.0-30.9	32	42	95	134.7	60	4.67	30
310-319-32T2-3D	31.0-31.9	32	42	98	137.9	60	4.85	31
320-329-40T2-3D	32.0-32.9	40	48	101	143.0	68	4.98	32
330-339-40T2-3D	33.0-33.9	40	48	104	146.2	68	5.16	33
340-349-40T2-3D	34.0-34.9	40	48	107	149.3	68	5.34	34
350-359-40T2-3D	35.0-35.9	40	48	110	152.4	68	5.44	35
360-369-40T2-3D	36.0-36.9	40	48	114	155.6	68	5.62	36
370-379-40T2-3D	37.0-37.9	40	48	117	158.8	68	5.80	37
380-389-40T2-3D	38.0-38.9	40	50	120	166.9	68	5.91	38
390-399-40T2-3D	39.0-39.9	40	50	123	170.1	68	6.09	39
400-410-40T2-3D	40.0-41.0	40	50	126	173.3	68	6.27	40

• OAL = LPR+LS • SSC : Размер кармана

Комплекующие

Обозначение	Винт	Ключ	Рукоятка ключа	
LCD 200-219-3D	TS 40178D25	BLD T20/S7	SW6-T-SH	
LCD 220-239-3D	TS 40198D28	BLD T20/S7	SW6-T-SH	
LCD 240-259-3D	TS 40210D3	BLD T20/S7	SW6-T-SH	
LCD 260-279-3D	TS 50230D3	BLD T20/S7	SW6-T-SH	
LCD 280-299-3D	TS 50250D35	BLD T25/S7	SW6-T-SH	
LCD 300-319-3D	TS 60265D4	BLD T25/S7	SW6-T-SH	
LCD 320-349-3D	TS 60285D42	BLD T25/S7	SW6-T-SH	
LCD 350-379-3D	TS 60320D5	BLD T25/S7	SW6-T-SH	
LCD 380-410-3D	TS 80340D6	BLD T25/S7	SW6-T-SH	



Модульное сверло с хвостовиком Weldon



- Глубина сверления: 5xD

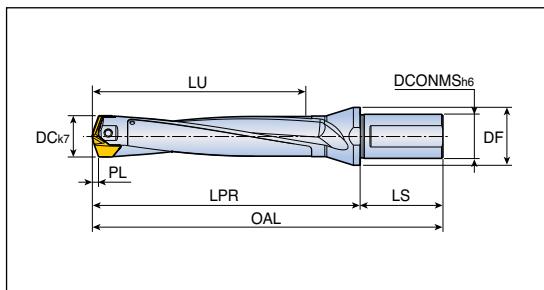

Обозначение	Размеры (мм)							
	DC	DCONMS	DF	LU	LPR	LS	PL	SSC
LCD 200-209-25T2-5D	20.0-20.9	25	32	103	132.1	56	3.11	20
210-219-25T2-5D	21.0-21.9	25	32	108	137.3	56	3.29	21
220-229-25T2-5D	22.0-22.9	25	32	113	142.4	56	3.42	22
230-239-25T2-5D	23.0-23.9	25	32	119	147.6	56	3.60	23
240-249-32T2-5D	24.0-24.9	32	40	124	158.7	60	3.73	24
250-259-32T2-5D	25.0-25.9	32	40	129	163.9	60	3.91	25
260-269-32T2-5D	26.0-26.9	32	40	134	169.0	60	4.04	26
270-279-32T2-5D	27.0-27.9	32	40	139	174.2	60	4.22	27
280-289-32T2-5D	28.0-28.9	32	40	144	184.4	60	4.35	28
290-299-32T2-5D	29.0-29.9	32	40	150	189.5	60	4.53	29
300-309-32T2-5D	30.0-30.9	32	42	155	194.7	60	4.67	30
310-319-32T2-5D	31.0-31.9	32	42	160	199.9	60	4.85	31
320-329-40T2-5D	32.0-32.9	40	48	165	207.0	68	4.98	32
330-339-40T2-5D	33.0-33.9	40	48	170	212.2	68	5.16	33
340-349-40T2-5D	34.0-34.9	40	48	175	217.3	68	5.34	34
350-359-40T2-5D	35.0-35.9	40	48	180	222.4	68	5.44	35
360-369-40T2-5D	36.0-36.9	40	48	186	227.6	68	5.62	36
370-379-40T2-5D	37.0-37.9	40	48	191	232.8	68	5.80	37
380-389-40T2-5D	38.0-38.9	40	50	196	242.9	68	5.91	38
390-399-40T2-5D	39.0-39.9	40	50	201	248.1	68	6.09	39
400-410-40T2-5D	40.0-41.0	40	50	206	253.3	68	6.27	40

- OAL = LPR+LS
- SSC : Размер кармана

Комплектующие

Обозначение	Винт	Ключ	Ручка ключа	
LCD 200-219-5D	TS 40178D25	BLD T20/S7	SW6-T-SH	
LCD 220-239-5D	TS 40198D28	BLD T20/S7	SW6-T-SH	
LCD 240-259-5D	TS 40210D3	BLD T20/S7	SW6-T-SH	
LCD 260-279-5D	TS 50230D3	BLD T20/S7	SW6-T-SH	
LCD 280-299-5D	TS 50250D35	BLD T25/S7	SW6-T-SH	
LCD 300-319-5D	TS 60265D4	BLD T25/S7	SW6-T-SH	
LCD 320-349-5D	TS 60285D42	BLD T25/S7	SW6-T-SH	
LCD 350-379-5D	TS 60320D5	BLD T25/S7	SW6-T-SH	
LCD 380-410-5D	TS 80340D6	BLD T25/S7	SW6-T-SH	



Сверло со сменными головками с хвостовиком Weldon



• Глубина сверления: 8xD

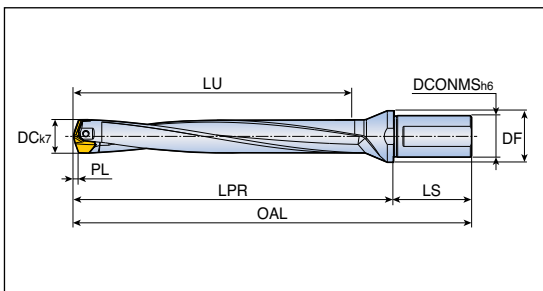

Обозначение	Размеры (мм)							
	DC	DCONMS	DF	LU	LPR	LS	PL	SSC
LCD 200-209-25T2-8D	20.0-20.9	25	32	163.1	192.1	56	3.11	20
210-219-25T2-8D	21.0-21.9	25	32	171.3	200.1	56	3.29	21
220-229-25T2-8D	22.0-22.9	25	32	179.4	208.4	56	3.42	22
230-239-25T2-8D	23.0-23.9	25	32	187.6	216.4	56	3.60	23
240-249-32T2-8D	24.0-24.9	32	40	195.7	230.7	60	3.73	24
250-259-32T2-8D	25.0-25.9	32	40	203.9	238.7	60	3.91	25
260-269-32T2-8D	26.0-26.9	32	40	212.0	247.0	60	4.04	26
270-279-32T2-8D	27.0-27.9	32	40	220.2	255.0	60	4.22	27
280-289-32T2-8D	28.0-28.9	32	40	228.4	268.4	60	4.35	28
290-299-32T2-8D	29.0-29.9	32	40	236.5	276.4	60	4.53	29
300-309-32T2-8D	30.0-30.9	32	42	244.7	284.7	60	4.67	30
310-319-32T2-8D	31.0-31.9	32	42	252.9	292.7	60	4.85	31
320-329-40T2-8D	32.0-32.9	40	48	261.0	303.0	68	4.98	32
330-339-40T2-8D	33.0-33.9	40	48	269.2	311.0	68	5.16	33
340-349-40T2-8D	34.0-34.9	40	48	277.3	319.0	68	5.34	34
350-359-40T2-8D	35.0-35.9	40	48	285.4	327.4	68	5.44	35
360-369-40T2-8D	36.0-36.9	40	48	293.6	335.4	68	5.62	36
370-379-40T2-8D	37.0-37.9	40	48	301.8	343.4	68	5.80	37
380-389-40T2-8D	38.0-38.9	40	50	309.9	356.9	68	5.91	38
390-399-40T2-8D	39.0-39.9	40	50	318.1	364.9	68	6.09	39
400-410-40T2-8D	40.0-41.0	40	50	326.3	372.9	68	6.27	40

• OAL = LPR + LS • SSC : Размер кармана • IPрекомендуется выполнять пилотное отверстие корпусом сверла 3D

Комплекующие

Обозначение	Винт	Ключ	Рукоятка ключа	
LCD 200-219-8D	TS 40178D25	BLD T20/S7	SW6-T-SH	
LCD 220-239-8D	TS 40198D28	BLD T20/S7	SW6-T-SH	
LCD 240-259-8D	TS 40210D3	BLD T20/S7	SW6-T-SH	
LCD 260-279-8D	TS 50230D3	BLD T20/S7	SW6-T-SH	
LCD 280-299-8D	TS 50250D35	BLD T25/S7	SW6-T-SH	
LCD 300-319-8D	TS 60265D4	BLD T25/S7	SW6-T-SH	
LCD 320-349-8D	TS 60285D42	BLD T25/S7	SW6-T-SH	
LCD 350-379-8D	TS 60320D5	BLD T25/S7	SW6-T-SH	
LCD 380-410-8D	TS 80340D6	BLD T25/S7	SW6-T-SH	



Трехперое монолитное твердосплавное сверло с каналами подачи СОЖ

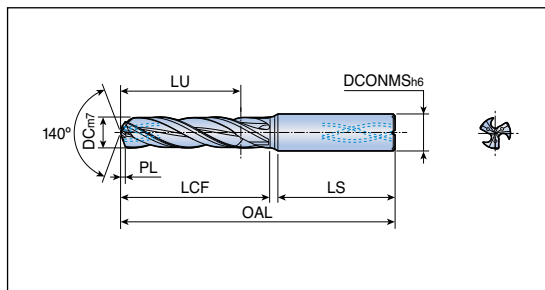

• Глубина сверления: 3xD



Обозначение	Размеры (мм)							Сплав TT5130
	DC	DCONMS	OAL	LU	LCF	LS	PL	
3HD 040-017-06 PI3	4.0	6.0	66	17	25	35	0.82	●
045-017-06 PI3	4.5	6.0	66	17	25	35	0.88	●
050-020-06 PI3	5.0	6.0	66	20	29	36	0.96	●
051-020-06 PI3	5.1	6.0	66	20	29	36	0.98	●
055-020-06 PI3	5.5	6.0	66	20	29	36	1.08	●
060-020-06 PI3	6.0	6.0	66	20	29	36	1.17	●
065-024-08 PI3	6.5	8.0	79	24	35	36	1.26	●
068-024-08 PI3	6.8	8.0	79	24	35	36	1.31	●
070-024-08 PI3	7.0	8.0	79	24	35	36	1.35	●
075-029-08 PI3	7.5	8.0	79	29	42	36	1.40	●
080-029-08 PI3	8.0	8.0	79	29	42	36	1.49	●
085-035-10 PI3	8.5	10.0	89	35	48	40	1.63	●
086-035-10 PI3	8.6	10.0	89	35	48	40	1.65	●
090-035-10 PI3	9.0	10.0	89	35	48	40	1.72	●
095-035-10 PI3	9.5	10.0	89	35	48	40	1.75	●
100-035-10 PI3	10.0	10.0	89	35	48	40	1.85	●
103-040-12 PI3	10.3	12.0	102	40	55	45	1.94	●
105-040-12 PI3	10.5	12.0	102	40	55	45	1.98	●
110-040-12 PI3	11.0	12.0	102	40	55	45	2.07	●
115-040-12 PI3	11.5	12.0	102	40	56	45	2.12	●
120-040-12 PI3	12.0	12.0	102	40	56	45	2.21	●



●: Стандартная позиция



Трехперое монокристаллическое твердосплавное сверло с каналами подачи СОЖ



• Глубина сверления: 5xD

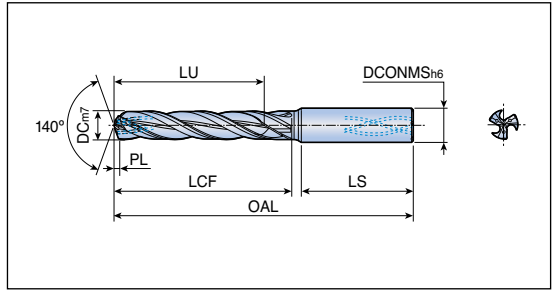

Обозначение	Размеры (мм)							Сплав
	DC	DCONMS	OAL	LU	LCF	LS	PL	TT5130
3HD 040-029-06 PI5	4.0	6.0	74	29	37	35	0.82	●
045-029-06 PI5	4.5	6.0	74	29	37	35	0.88	●
050-035-06 PI5	5.0	6.0	82	35	45	36	0.96	●
051-035-06 PI5	5.1	6.0	82	35	45	36	0.98	●
055-035-06 PI5	5.5	6.0	82	35	45	36	1.08	●
060-035-06 PI5	6.0	6.0	82	35	45	36	1.17	●
065-043-08 PI5	6.5	8.0	91	43	54	36	1.26	●
068-043-08 PI5	6.8	8.0	91	43	54	36	1.31	●
070-043-08 PI5	7.0	8.0	91	43	54	36	1.35	●
075-043-08 PI5	7.5	8.0	91	43	54	36	1.40	●
080-043-08 PI5	8.0	8.0	91	43	54	36	1.49	●
085-049-10 PI5	8.5	10.0	103	49	62	40	1.63	●
086-049-10 PI5	8.6	10.0	103	49	62	40	1.65	●
090-049-10 PI5	9.0	10.0	103	49	62	40	1.72	●
095-049-10 PI5	9.5	10.0	103	49	62	40	1.75	●
100-049-10 PI5	10.0	10.0	103	49	62	40	1.85	●
103-056-12 PI5	10.3	12.0	118	56	71	45	1.94	●
105-056-12 PI5	10.5	12.0	118	56	71	45	1.98	●
110-056-12 PI5	11.0	12.0	118	56	71	45	2.07	●
115-056-12 PI5	11.5	12.0	118	56	72	45	2.12	●
120-056-12 PI5	12.0	12.0	118	56	72	45	2.21	●

●: Стандартная позиция



Монолитное твердосплавное сверло без каналов подачи СОЖ



• Глубина сверления: 3xD

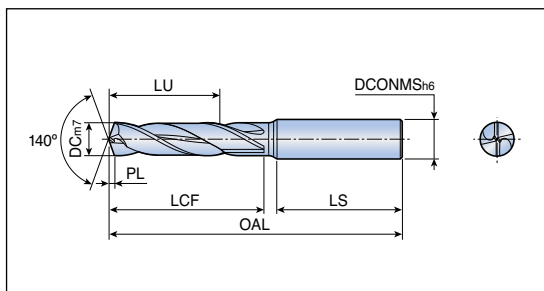

Обозначение	Размеры (мм)							Сплав
	DC	DCONMS	OAL	LU	LCF	LS	PL	TT9030
NHD 030-014-06 PE3	3.0	6.0	62	14	20	34	0.5	●
031-014-06 PE3	3.1	6.0	62	14	20	34	0.5	●
032-014-06 PE3	3.2	6.0	62	14	20	34	0.5	●
033-014-06 PE3	3.3	6.0	62	14	20	34	0.5	●
034-014-06 PE3	3.4	6.0	62	14	20	34	0.5	●
035-014-06 PE3	3.5	6.0	62	14	20	34	0.6	●
036-014-06 PE3	3.6	6.0	62	14	20	34	0.6	●
037-014-06 PE3	3.7	6.0	62	14	20	34	0.6	●
038-017-06 PE3	3.8	6.0	66	17	24	35	0.6	●
039-017-06 PE3	3.9	6.0	66	17	24	35	0.6	●
040-017-06 PE3	4.0	6.0	66	17	24	35	0.6	●
041-017-06 PE3	4.1	6.0	66	17	24	35	0.7	●
042-017-06 PE3	4.2	6.0	66	17	24	35	0.7	●
043-017-06 PE3	4.3	6.0	66	17	24	35	0.7	●
044-017-06 PE3	4.4	6.0	66	17	24	35	0.7	●
045-017-06 PE3	4.5	6.0	66	17	24	35	0.7	●
046-017-06 PE3	4.6	6.0	66	17	24	35	0.7	●
047-017-06 PE3	4.7	6.0	66	17	24	35	0.8	●
048-020-06 PE3	4.8	6.0	66	20	28	36	0.8	●
049-020-06 PE3	4.9	6.0	66	20	28	36	0.8	●
050-020-06 PE3	5.0	6.0	66	20	28	36	0.8	●
051-020-06 PE3	5.1	6.0	66	20	28	36	0.8	●
052-020-06 PE3	5.2	6.0	66	20	28	36	0.8	●
053-020-06 PE3	5.3	6.0	66	20	28	36	0.8	●
054-020-06 PE3	5.4	6.0	66	20	28	36	0.8	●
055-020-06 PE3	5.5	6.0	66	20	28	36	0.9	●
056-020-06 PE3	5.6	6.0	66	20	28	36	0.9	●
057-020-06 PE3	5.7	6.0	66	20	28	36	0.9	●
058-020-06 PE3	5.8	6.0	66	20	28	36	0.9	●
059-020-06 PE3	5.9	6.0	66	20	28	36	0.9	●
060-020-06 PE3	6.0	6.0	66	20	28	36	0.9	●
061-024-08 PE3	6.1	8.0	79	24	34	36	1.0	●
062-024-08 PE3	6.2	8.0	79	24	34	36	1.0	●
063-024-08 PE3	6.3	8.0	79	24	34	36	1.0	●
064-024-08 PE3	6.4	8.0	79	24	34	36	1.0	●



●: Стандартная позиция

Монолитное твердосплавное сверло без каналов подачи СОЖ



• Глубина сверления: 3xD

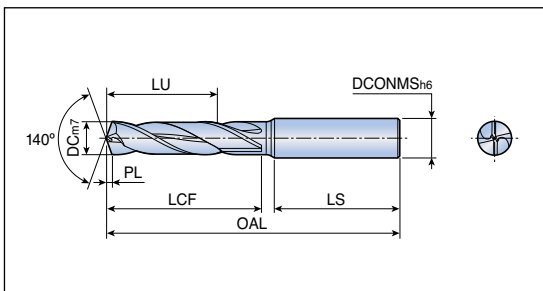

Обозначение	Размеры (мм)							Сплав
	DC	DCONMS	OAL	LU	LCF	LS	PL	ТТ9030
NHD 065-024-08 PE3	6.5	8.0	79	24	34	36	1.0	●
066-024-08 PE3	6.6	8.0	79	24	34	36	1.0	●
067-024-08 PE3	6.7	8.0	79	24	34	36	1.1	●
068-024-08 PE3	6.8	8.0	79	24	34	36	1.1	●
069-024-08 PE3	6.9	8.0	79	24	34	36	1.1	●
070-024-08 PE3	7.0	8.0	79	24	34	36	1.1	●
071-029-08 PE3	7.1	8.0	79	29	41	36	1.1	●
072-029-08 PE3	7.2	8.0	79	29	41	36	1.1	●
073-029-08 PE3	7.3	8.0	79	29	41	36	1.1	●
074-029-08 PE3	7.4	8.0	79	29	41	36	1.2	●
075-029-08 PE3	7.5	8.0	79	29	41	36	1.2	●
076-029-08 PE3	7.6	8.0	79	29	41	36	1.2	●
077-029-08 PE3	7.7	8.0	79	29	41	36	1.2	●
078-029-08 PE3	7.8	8.0	79	29	41	36	1.2	●
079-029-08 PE3	7.9	8.0	79	29	41	36	1.3	●
080-029-08 PE3	8.0	8.0	79	29	41	36	1.3	●
081-035-10 PE3	8.1	10.0	89	35	47	40	1.3	●
082-035-10 PE3	8.2	10.0	89	35	47	40	1.3	●
083-035-10 PE3	8.3	10.0	89	35	47	40	1.3	●
084-035-10 PE3	8.4	10.0	89	35	47	40	1.3	●
085-035-10 PE3	8.5	10.0	89	35	47	40	1.3	●
086-035-10 PE3	8.6	10.0	89	35	47	40	1.4	●
087-035-10 PE3	8.7	10.0	89	35	47	40	1.4	●
088-035-10 PE3	8.8	10.0	89	35	47	40	1.4	●
089-035-10 PE3	8.9	10.0	89	35	47	40	1.4	●
090-035-10 PE3	9.0	10.0	89	35	47	40	1.4	●
091-035-10 PE3	9.1	10.0	89	35	47	40	1.4	●
092-035-10 PE3	9.2	10.0	89	35	47	40	1.4	●
093-035-10 PE3	9.3	10.0	89	35	47	40	1.5	●
094-035-10 PE3	9.4	10.0	89	35	47	40	1.5	●
095-035-10 PE3	9.5	10.0	89	35	47	40	1.5	●
096-035-10 PE3	9.6	10.0	89	35	47	40	1.5	●
097-035-10 PE3	9.7	10.0	89	35	47	40	1.5	●
098-035-10 PE3	9.8	10.0	89	35	47	40	1.6	●
099-035-10 PE3	9.9	10.0	89	35	47	40	1.6	●

●: Стандартная позиция



Монолитное твердосплавное сверло без каналов подачи СОЖ



• Глубина сверления: 3xD

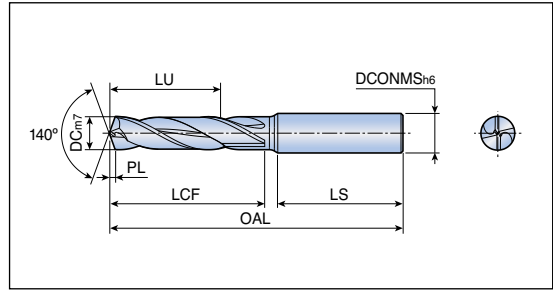

Обозначение	Размеры (мм)							Сплав ТТ9030
	DC	DCONMS	OAL	LU	LCF	LS	PL	
NHD 100-035-10 PE3	10.0	10.0	89	35	47	40	1.6	●
101-040-12 PE3	10.1	12.0	101	40	55	45	1.6	●
102-040-12 PE3	10.2	12.0	101	40	55	45	1.6	●
103-040-12 PE3	10.3	12.0	101	40	55	45	1.6	●
104-040-12 PE3	10.4	12.0	101	40	55	45	1.6	●
105-040-12 PE3	10.5	12.0	101	40	55	45	1.6	●
106-040-12 PE3	10.6	12.0	101	40	55	45	1.7	●
107-040-12 PE3	10.7	12.0	101	40	55	45	1.7	●
108-040-12 PE3	10.8	12.0	101	40	55	45	1.7	●
109-040-12 PE3	10.9	12.0	101	40	55	45	1.7	●
110-040-12 PE3	11.0	12.0	101	40	55	45	1.7	●
111-040-12 PE3	11.1	12.0	101	40	55	45	1.7	●
112-040-12 PE3	11.2	12.0	101	40	55	45	1.8	●
113-040-12 PE3	11.3	12.0	101	40	55	45	1.8	●
114-040-12 PE3	11.4	12.0	101	40	55	45	1.8	●
115-040-12 PE3	11.5	12.0	101	40	55	45	1.8	●
116-040-12 PE3	11.6	12.0	101	40	55	45	1.8	●
117-040-12 PE3	11.7	12.0	101	40	55	45	1.9	●
118-040-12 PE3	11.8	12.0	101	40	55	45	1.9	●
119-040-12 PE3	11.9	12.0	101	40	55	45	1.9	●
120-040-12 PE3	12.0	12.0	101	40	55	45	1.9	●



●: Стандартная позиция

Монолитное твердосплавное сверло без каналов подачи СОЖ



• Глубина сверления: 4-5xD

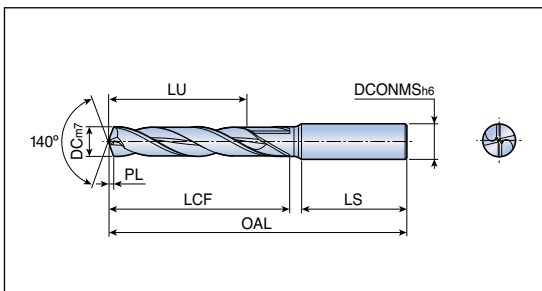

Обозначение	Размеры (мм)							Сплав
	DC	DCONMS	OAL	LU	LCF	LS	PL	TT9030
NHD 030-023-06 PE5	3.0	6.0	66	23	28	34	0.5	●
031-023-06 PE5	3.1	6.0	66	23	28	34	0.5	●
032-023-06 PE5	3.2	6.0	66	23	28	34	0.5	●
033-023-06 PE5	3.3	6.0	66	23	28	34	0.5	●
034-023-06 PE5	3.4	6.0	66	23	28	34	0.5	●
035-023-06 PE5	3.5	6.0	66	23	28	34	0.6	●
036-023-06 PE5	3.6	6.0	66	23	28	34	0.6	●
037-023-06 PE5	3.7	6.0	66	23	28	34	0.6	●
038-029-06 PE5	3.8	6.0	74	29	36	35	0.6	●
039-029-06 PE5	3.9	6.0	74	29	36	35	0.6	●
040-029-06 PE5	4.0	6.0	74	29	36	35	0.6	●
041-029-06 PE5	4.1	6.0	74	29	36	35	0.7	●
042-029-06 PE5	4.2	6.0	74	29	36	35	0.7	●
043-029-06 PE5	4.3	6.0	74	29	36	35	0.7	●
044-029-06 PE5	4.4	6.0	74	29	36	35	0.7	●
045-029-06 PE5	4.5	6.0	74	29	36	35	0.7	●
046-029-06 PE5	4.6	6.0	74	29	36	35	0.7	●
047-029-06 PE5	4.7	6.0	74	29	36	35	0.8	●
048-035-06 PE5	4.8	6.0	82	35	44	36	0.8	●
049-035-06 PE5	4.9	6.0	82	35	44	36	0.8	●
050-035-06 PE5	5.0	6.0	82	35	44	36	0.8	●
051-035-06 PE5	5.1	6.0	82	35	44	36	0.8	●
052-035-06 PE5	5.2	6.0	82	35	44	36	0.8	●
053-035-06 PE5	5.3	6.0	82	35	44	36	0.8	●
054-035-06 PE5	5.4	6.0	82	35	44	36	0.8	●
055-035-06 PE5	5.5	6.0	82	35	44	36	0.9	●
056-035-06 PE5	5.6	6.0	82	35	44	36	0.9	●
057-035-06 PE5	5.7	6.0	82	35	44	36	0.9	●
058-035-06 PE5	5.8	6.0	82	35	44	36	0.9	●
059-035-06 PE5	5.9	6.0	82	35	44	36	0.9	●
060-035-06 PE5	6.0	6.0	82	35	44	36	0.9	●
061-043-08 PE5	6.1	8.0	91	43	53	36	1.0	●
062-043-08 PE5	6.2	8.0	91	43	53	36	1.0	●
063-043-08 PE5	6.3	8.0	91	43	53	36	1.0	●
064-043-08 PE5	6.4	8.0	91	43	53	36	1.0	●

●: Стандартная позиция



Монолитное твердосплавное сверло без каналов подачи СОЖ



• Глубина сверления: 4-5xD

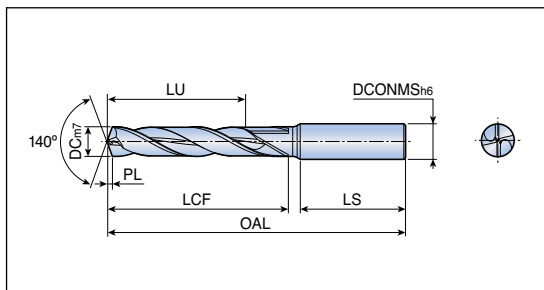

Обозначение	Размеры (мм)							Сплав ТТ9030
	DC	DCONMS	OAL	LU	LCF	LS	PL	
NHD 065-043-08 PE5	6.5	8.0	91	43	53	36	1.0	●
066-043-08 PE5	6.6	8.0	91	43	53	36	1.0	●
067-043-08 PE5	6.7	8.0	91	43	53	36	1.1	●
068-043-08 PE5	6.8	8.0	91	43	53	36	1.1	●
069-043-08 PE5	6.9	8.0	91	43	53	36	1.1	●
070-043-08 PE5	7.0	8.0	91	43	53	36	1.1	●
071-043-08 PE5	7.1	8.0	91	43	53	36	1.1	●
072-043-08 PE5	7.2	8.0	91	43	53	36	1.1	●
073-043-08 PE5	7.3	8.0	91	43	53	36	1.1	●
074-043-08 PE5	7.4	8.0	91	43	53	36	1.2	●
075-043-08 PE5	7.5	8.0	91	43	53	36	1.2	●
076-043-08 PE5	7.6	8.0	91	43	53	36	1.2	●
077-043-08 PE5	7.7	8.0	91	43	53	36	1.2	●
078-043-08 PE5	7.8	8.0	91	43	53	36	1.2	●
079-043-08 PE5	7.9	8.0	91	43	53	36	1.3	●
080-043-08 PE5	8.0	8.0	91	43	53	36	1.3	●
081-049-10 PE5	8.1	10.0	103	49	61	40	1.3	●
082-049-10 PE5	8.2	10.0	103	49	61	40	1.3	●
083-049-10 PE5	8.3	10.0	103	49	61	40	1.3	●
084-049-10 PE5	8.4	10.0	103	49	61	40	1.3	●
085-049-10 PE5	8.5	10.0	103	49	61	40	1.3	●
086-049-10 PE5	8.6	10.0	103	49	61	40	1.4	●
087-049-10 PE5	8.7	10.0	103	49	61	40	1.4	●
088-049-10 PE5	8.8	10.0	103	49	61	40	1.4	●
089-049-10 PE5	8.9	10.0	103	49	61	40	1.4	●
090-049-10 PE5	9.0	10.0	103	49	61	40	1.4	●
091-049-10 PE5	9.1	10.0	103	49	61	40	1.4	●
092-049-10 PE5	9.2	10.0	103	49	61	40	1.4	●
093-049-10 PE5	9.3	10.0	103	49	61	40	1.5	●
094-049-10 PE5	9.4	10.0	103	49	61	40	1.5	●
095-049-10 PE5	9.5	10.0	103	49	61	40	1.5	●
096-049-10 PE5	9.6	10.0	103	49	61	40	1.5	●
097-049-10 PE5	9.7	10.0	103	49	61	40	1.5	●
098-049-10 PE5	9.8	10.0	103	49	61	40	1.6	●
099-049-10 PE5	9.9	10.0	103	49	61	40	1.6	●



●: Стандартная позиция

Монолитное твердосплавное сверло без каналов подачи СОЖ



● Глубина сверления: 4-5хD

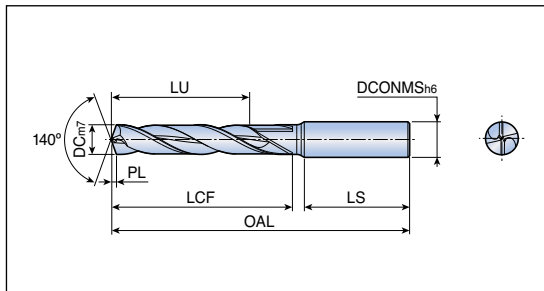

Обозначение	Размеры (мм)							Сплав
	DC	DCONMS	OAL	LU	LCF	PL	LS	ТТ9030
NHD 100-049-10 PE5	10.0	10.0	103	49	61	1.6	40	●
101-056-12 PE5	10.1	12.0	118	56	71	1.6	45	●
102-056-12 PE5	10.2	12.0	118	56	71	1.6	45	●
103-056-12 PE5	10.3	12.0	118	56	71	1.6	45	●
104-056-12 PE5	10.4	12.0	118	56	71	1.6	45	●
105-056-12 PE5	10.5	12.0	118	56	71	1.6	45	●
106-056-12 PE5	10.6	12.0	118	56	71	1.7	45	●
107-056-12 PE5	10.7	12.0	118	56	71	1.7	45	●
108-056-12 PE5	10.8	12.0	118	56	71	1.7	45	●
109-056-12 PE5	10.9	12.0	118	56	71	1.7	45	●
110-056-12 PE5	11.0	12.0	118	56	71	1.7	45	●
111-056-12 PE5	11.1	12.0	118	56	71	1.7	45	●
112-056-12 PE5	11.2	12.0	118	56	71	1.8	45	●
113-056-12 PE5	11.3	12.0	118	56	71	1.8	45	●
114-056-12 PE5	11.4	12.0	118	56	71	1.8	45	●
115-056-12 PE5	11.5	12.0	118	56	71	1.8	45	●
116-056-12 PE5	11.6	12.0	118	56	71	1.8	45	●
117-056-12 PE5	11.7	12.0	118	56	71	1.9	45	●
118-056-12 PE5	11.8	12.0	118	56	71	1.9	45	●
119-056-12 PE5	11.9	12.0	118	56	71	1.9	45	●
120-056-12 PE5	12.0	12.0	118	56	71	1.9	45	●

●: Стандартная позиция



Монолитное твердосплавное сверло с каналами подачи СОЖ

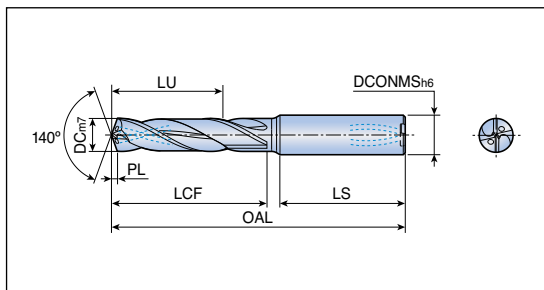

• Глубина сверления: 3xD



Обозначение	Размеры (мм)							Сплав
	DC	DCONMS	OAL	LU	LCF	LS	PL	TT9030
NHD 030-014-06 PI3	3.0	6.0	62	14	20	34	0.5	●
031-014-06 PI3	3.1	6.0	62	14	20	34	0.5	●
032-014-06 PI3	3.2	6.0	62	14	20	34	0.5	●
033-014-06 PI3	3.3	6.0	62	14	20	34	0.5	●
034-014-06 PI3	3.4	6.0	62	14	20	34	0.5	●
035-014-06 PI3	3.5	6.0	62	14	20	34	0.6	●
036-014-06 PI3	3.6	6.0	62	14	20	34	0.6	●
037-014-06 PI3	3.7	6.0	62	14	20	34	0.6	●
038-017-06 PI3	3.8	6.0	66	17	24	35	0.6	●
039-017-06 PI3	3.9	6.0	66	17	24	35	0.6	●
040-017-06 PI3	4.0	6.0	66	17	24	35	0.6	●
041-017-06 PI3	4.1	6.0	66	17	24	35	0.7	●
042-017-06 PI3	4.2	6.0	66	17	24	35	0.7	●
043-017-06 PI3	4.3	6.0	66	17	24	35	0.7	●
044-017-06 PI3	4.4	6.0	66	17	24	35	0.7	●
045-017-06 PI3	4.5	6.0	66	17	24	35	0.7	●
046-017-06 PI3	4.6	6.0	66	17	24	35	0.7	●
047-017-06 PI3	4.7	6.0	66	17	24	35	0.8	●
048-020-06 PI3	4.8	6.0	66	20	28	36	0.8	●
049-020-06 PI3	4.9	6.0	66	20	28	36	0.8	●
050-020-06 PI3	5.0	6.0	66	20	28	36	0.8	●
051-020-06 PI3	5.1	6.0	66	20	28	36	0.8	●
052-020-06 PI3	5.2	6.0	66	20	28	36	0.8	●
053-020-06 PI3	5.3	6.0	66	20	28	36	0.8	●
054-020-06 PI3	5.4	6.0	66	20	28	36	0.8	●
055-020-06 PI3	5.5	6.0	66	20	28	36	0.9	●
056-020-06 PI3	5.6	6.0	66	20	28	36	0.9	●
057-020-06 PI3	5.7	6.0	66	20	28	36	0.9	●
058-020-06 PI3	5.8	6.0	66	20	28	36	0.9	●
059-020-06 PI3	5.9	6.0	66	20	28	36	0.9	●
060-020-06 PI3	6.0	6.0	66	20	28	36	0.9	●
061-024-08 PI3	6.1	8.0	79	24	34	36	1.0	●
062-024-08 PI3	6.2	8.0	79	24	34	36	1.0	●
063-024-08 PI3	6.3	8.0	79	24	34	36	1.0	●
064-024-08 PI3	6.4	8.0	79	24	34	36	1.0	●



●: Стандартная позиция

Монолитное твердосплавное сверло с каналами подачи СОЖ



• Глубина сверления: 3xD

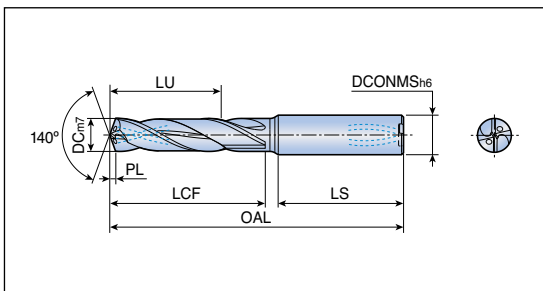

Обозначение	Размеры (мм)							Сплав
	DC	DCONMS	OAL	LU	LCF	LS	PL	TT9030
NHD 065-024-08 PI3	6.5	8.0	79	24	34	36	1.0	•
066-024-08 PI3	6.6	8.0	79	24	34	36	1.0	•
067-024-08 PI3	6.7	8.0	79	24	34	36	1.1	•
068-024-08 PI3	6.8	8.0	79	24	34	36	1.1	•
069-024-08 PI3	6.9	8.0	79	24	34	36	1.1	•
070-024-08 PI3	7.0	8.0	79	24	34	36	1.1	•
071-029-08 PI3	7.1	8.0	79	29	41	36	1.1	•
072-029-08 PI3	7.2	8.0	79	29	41	36	1.1	•
073-029-08 PI3	7.3	8.0	79	29	41	36	1.1	•
074-029-08 PI3	7.4	8.0	79	29	41	36	1.2	•
075-029-08 PI3	7.5	8.0	79	29	41	36	1.2	•
076-029-08 PI3	7.6	8.0	79	29	41	36	1.2	•
077-029-08 PI3	7.7	8.0	79	29	41	36	1.2	•
078-029-08 PI3	7.8	8.0	79	29	41	36	1.2	•
079-029-08 PI3	7.9	8.0	79	29	41	36	1.3	•
080-029-08 PI3	8.0	8.0	79	29	41	36	1.3	•
081-035-10 PI3	8.1	10.0	89	35	47	40	1.3	•
082-035-10 PI3	8.2	10.0	89	35	47	40	1.3	•
083-035-10 PI3	8.3	10.0	89	35	47	40	1.3	•
084-035-10 PI3	8.4	10.0	89	35	47	40	1.3	•
085-035-10 PI3	8.5	10.0	89	35	47	40	1.3	•
086-035-10 PI3	8.6	10.0	89	35	47	40	1.4	•
087-035-10 PI3	8.7	10.0	89	35	47	40	1.4	•
088-035-10 PI3	8.8	10.0	89	35	47	40	1.4	•
089-035-10 PI3	8.9	10.0	89	35	47	40	1.4	•
090-035-10 PI3	9.0	10.0	89	35	47	40	1.4	•
091-035-10 PI3	9.1	10.0	89	35	47	40	1.4	•
092-035-10 PI3	9.2	10.0	89	35	47	40	1.4	•
093-035-10 PI3	9.3	10.0	89	35	47	40	1.5	•
094-035-10 PI3	9.4	10.0	89	35	47	40	1.5	•
095-035-10 PI3	9.5	10.0	89	35	47	40	1.5	•
096-035-10 PI3	9.6	10.0	89	35	47	40	1.5	•
097-035-10 PI3	9.7	10.0	89	35	47	40	1.5	•
098-035-10 PI3	9.8	10.0	89	35	47	40	1.6	•
099-035-10 PI3	9.9	10.0	89	35	47	40	1.6	•

•: Стандартная позиция



Монолитное твердосплавное сверло с каналами подачи СОЖ



• Глубина сверления: 3xD

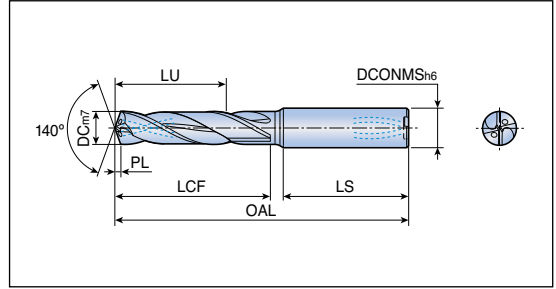

Обозначение	Размеры (мм)							Сплав ТТ9030
	DC	DCONMS	OAL	LU	LCF	LS	PL	
NHD 100-035-10 PI3	10.0	10.0	89	35	47	40	1.6	•
101-040-12 PI3	10.1	12.0	102	40	55	45	1.6	•
102-040-12 PI3	10.2	12.0	102	40	55	45	1.6	•
103-040-12 PI3	10.3	12.0	102	40	55	45	1.6	•
104-040-12 PI3	10.4	12.0	102	40	55	45	1.6	•
105-040-12 PI3	10.5	12.0	102	40	55	45	1.6	•
106-040-12 PI3	10.6	12.0	102	40	55	45	1.7	•
107-040-12 PI3	10.7	12.0	102	40	55	45	1.7	•
108-040-12 PI3	10.8	12.0	102	40	55	45	1.7	•
109-040-12 PI3	10.9	12.0	102	40	55	45	1.7	•
110-040-12 PI3	11.0	12.0	102	40	55	45	1.7	•
111-040-12 PI3	11.1	12.0	102	40	55	45	1.7	•
112-040-12 PI3	11.2	12.0	102	40	55	45	1.8	•
113-040-12 PI3	11.3	12.0	102	40	55	45	1.8	•
114-040-12 PI3	11.4	12.0	102	40	55	45	1.8	•
115-040-12 PI3	11.5	12.0	102	40	55	45	1.8	•
116-040-12 PI3	11.6	12.0	102	40	55	45	1.8	•
117-040-12 PI3	11.7	12.0	102	40	55	45	1.9	•
118-040-12 PI3	11.8	12.0	102	40	55	45	1.9	•
119-040-12 PI3	11.9	12.0	102	40	55	45	1.9	•
120-040-12 PI3	12.0	12.0	102	40	55	45	1.9	•



•: Стандартная позиция

Монолитное твердосплавное сверло с каналами подачи СОЖ



• Глубина сверления: 4-5xD

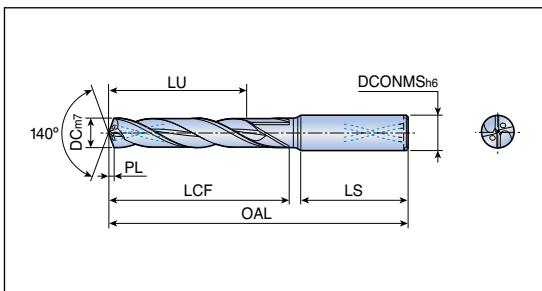

Обозначение	Размеры (мм)							Сплав
	DC	DCONMS	OAL	LU	LCF	LS	PL	TT9030
NHD 030-023-06 PI5	3.0	6.0	66	23	28	34	0.5	●
031-023-06 PI5	3.1	6.0	66	23	28	34	0.5	●
032-023-06 PI5	3.2	6.0	66	23	28	34	0.5	●
033-023-06 PI5	3.3	6.0	66	23	28	34	0.5	●
034-023-06 PI5	3.4	6.0	66	23	28	34	0.5	●
035-023-06 PI5	3.5	6.0	66	23	28	34	0.6	●
036-023-06 PI5	3.6	6.0	66	23	28	34	0.6	●
037-023-06 PI5	3.7	6.0	66	23	28	34	0.6	●
038-029-06 PI5	3.8	6.0	74	29	36	35	0.6	●
039-029-06 PI5	3.9	6.0	74	29	36	35	0.6	●
040-029-06 PI5	4.0	6.0	74	29	36	35	0.6	●
041-029-06 PI5	4.1	6.0	74	29	36	35	0.7	●
042-029-06 PI5	4.2	6.0	74	29	36	35	0.7	●
043-029-06 PI5	4.3	6.0	74	29	36	35	0.7	●
044-029-06 PI5	4.4	6.0	74	29	36	35	0.7	●
045-029-06 PI5	4.5	6.0	74	29	36	35	0.7	●
046-029-06 PI5	4.6	6.0	74	29	36	35	0.7	●
047-029-06 PI5	4.7	6.0	74	29	36	35	0.8	●
048-035-06 PI5	4.8	6.0	82	35	44	36	0.8	●
049-035-06 PI5	4.9	6.0	82	35	44	36	0.8	●
050-035-06 PI5	5.0	6.0	82	35	44	36	0.8	●
051-035-06 PI5	5.1	6.0	82	35	44	36	0.8	●
052-035-06 PI5	5.2	6.0	82	35	44	36	0.8	●
053-035-06 PI5	5.3	6.0	82	35	44	36	0.8	●
054-035-06 PI5	5.4	6.0	82	35	44	36	0.8	●
055-035-06 PI5	5.5	6.0	82	35	44	36	0.9	●
056-035-06 PI5	5.6	6.0	82	35	44	36	0.9	●
057-035-06 PI5	5.7	6.0	82	35	44	36	0.9	●
058-035-06 PI5	5.8	6.0	82	35	44	36	0.9	●
059-035-06 PI5	5.9	6.0	82	35	44	36	0.9	●
060-035-06 PI5	6.0	6.0	82	35	44	36	0.9	●
061-043-08 PI5	6.1	8.0	91	43	53	36	1.0	●
062-043-08 PI5	6.2	8.0	91	43	53	36	1.0	●
063-043-08 PI5	6.3	8.0	91	43	53	36	1.0	●
064-043-08 PI5	6.4	8.0	91	43	53	36	1.0	●

●: Стандартная позиция



Монолитное твердосплавное сверло с каналами подачи СОЖ



• Глубина сверления: 4-5xD

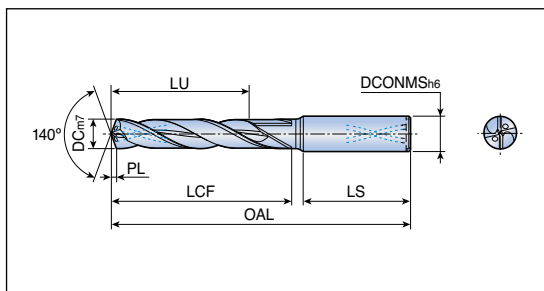

Обозначение	Размеры (мм)							Сплав ТТ9030
	DC	DCONMS	OAL	LU	LCF	LS	PL	
NHD 065-043-08 PI5	6.5	8.0	91	43	53	36	1.0	●
066-043-08 PI5	6.6	8.0	91	43	53	36	1.0	●
067-043-08 PI5	6.7	8.0	91	43	53	36	1.1	●
068-043-08 PI5	6.8	8.0	91	43	53	36	1.1	●
069-043-08 PI5	6.9	8.0	91	43	53	36	1.1	●
070-043-08 PI5	7.0	8.0	91	43	53	36	1.1	●
071-043-08 PI5	7.1	8.0	91	43	53	36	1.1	●
072-043-08 PI5	7.2	8.0	91	43	53	36	1.1	●
073-043-08 PI5	7.3	8.0	91	43	53	36	1.1	●
074-043-08 PI5	7.4	8.0	91	43	53	36	1.2	●
075-043-08 PI5	7.5	8.0	91	43	53	36	1.2	●
076-043-08 PI5	7.6	8.0	91	43	53	36	1.2	●
077-043-08 PI5	7.7	8.0	91	43	53	36	1.2	●
078-043-08 PI5	7.8	8.0	91	43	53	36	1.2	●
079-043-08 PI5	7.9	8.0	91	43	53	36	1.3	●
080-043-08 PI5	8.0	8.0	91	43	53	36	1.3	●
081-049-10 PI5	8.1	10.0	103	49	61	40	1.3	●
082-049-10 PI5	8.2	10.0	103	49	61	40	1.3	●
083-049-10 PI5	8.3	10.0	103	49	61	40	1.3	●
084-049-10 PI5	8.4	10.0	103	49	61	40	1.3	●
085-049-10 PI5	8.5	10.0	103	49	61	40	1.3	●
086-049-10 PI5	8.6	10.0	103	49	61	40	1.4	●
087-049-10 PI5	8.7	10.0	103	49	61	40	1.4	●
088-049-10 PI5	8.8	10.0	103	49	61	40	1.4	●
089-049-10 PI5	8.9	10.0	103	49	61	40	1.4	●
090-049-10 PI5	9.0	10.0	103	49	61	40	1.4	●
091-049-10 PI5	9.1	10.0	103	49	61	40	1.4	●
092-049-10 PI5	9.2	10.0	103	49	61	40	1.4	●
093-049-10 PI5	9.3	10.0	103	49	61	40	1.5	●
094-049-10 PI5	9.4	10.0	103	49	61	40	1.5	●
095-049-10 PI5	9.5	10.0	103	49	61	40	1.5	●
096-049-10 PI5	9.6	10.0	103	49	61	40	1.5	●
097-049-10 PI5	9.7	10.0	103	49	61	40	1.5	●
098-049-10 PI5	9.8	10.0	103	49	61	40	1.6	●
099-049-10 PI5	9.9	10.0	103	49	61	40	1.6	●



●: Стандартная позиция

Монолитное твердосплавное сверло с каналами подачи СОЖ



• Глубина сверления: 4-5xD

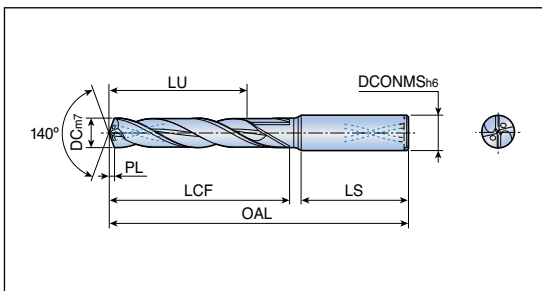

Обозначение	Размеры (мм)							Сплав TT9030
	DC	DCONMS	OAL	LU	LCF	LS	PL	
NHD 100-049-10 PI5	10.0	10.0	103	49	61	40	1.6	●
101-056-12 PI5	10.1	12.0	118	56	71	45	1.6	●
102-056-12 PI5	10.2	12.0	118	56	71	45	1.6	●
103-056-12 PI5	10.3	12.0	118	56	71	45	1.6	●
104-056-12 PI5	10.4	12.0	118	56	71	45	1.6	●
105-056-12 PI5	10.5	12.0	118	56	71	45	1.6	●
106-056-12 PI5	10.6	12.0	118	56	71	45	1.7	●
107-056-12 PI5	10.7	12.0	118	56	71	45	1.7	●
108-056-12 PI5	10.8	12.0	118	56	71	45	1.7	●
109-056-12 PI5	10.9	12.0	118	56	71	45	1.7	●
110-056-12 PI5	11.0	12.0	118	56	71	45	1.7	●
111-056-12 PI5	11.1	12.0	118	56	71	45	1.7	●
112-056-12 PI5	11.2	12.0	118	56	71	45	1.8	●
113-056-12 PI5	11.3	12.0	118	56	71	45	1.8	●
114-056-12 PI5	11.4	12.0	118	56	71	45	1.8	●
115-056-12 PI5	11.5	12.0	118	56	71	45	1.8	●
116-056-12 PI5	11.6	12.0	118	56	71	45	1.8	●
117-056-12 PI5	11.7	12.0	118	56	71	45	1.9	●
118-056-12 PI5	11.8	12.0	118	56	71	45	1.9	●
119-056-12 PI5	11.9	12.0	118	56	71	45	1.9	●
120-056-12 PI5	12.0	12.0	118	56	71	45	1.9	●

●: Стандартная позиция



SHO 3...-PH



Монолитное пилотное сверло с каналами подачи СОЖ



- Сверление с минимальным количеством СОЖ

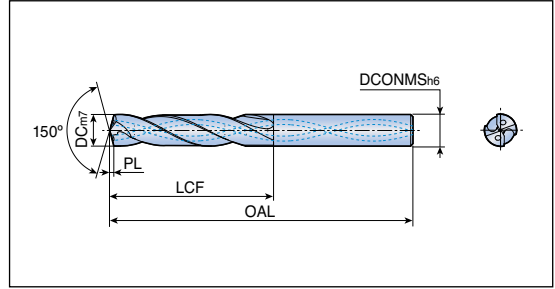

Обозначение	Размеры (мм)					Сплав
	DC	DCONMS	OAL	LCF	PL	TT9030
SHO 30403-PH	4.03	4	66.5	24.5	0.5	●
30503-PH	5.03	5	68.6	30.6	0.6	●
30603-PH	6.03	6	68.7	30.7	0.7	●
30703-PH	7.03	7	73.8	35.8	0.8	●
30803-PH	8.03	8	79.9	41.9	0.9	●
30903-PH	9.03	9	91.0	49.0	1.0	●
31003-PH	10.03	10	91.1	49.1	1.1	●



●: Стандартная позиция



Удлиненное монолитное сверло с каналами подачи СОЖ



- Глубина сверления: 10/15/20xD
- Сверление с минимальным количеством СОЖ

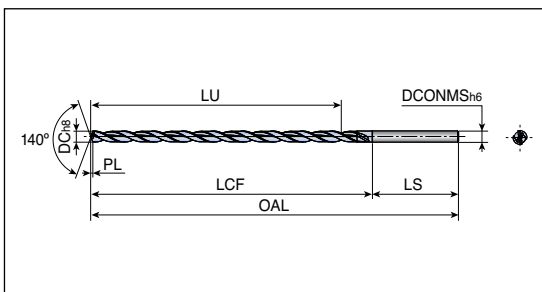

Обозначение	Размеры (мм)							Сплав
	DC	DCONMS	OAL	LU	LCF	LS	PL	TT9030
SHO 10040	4.0	4	105.6	50	55.6	50	0.6	●
10050	5.0	5	115.8	60	65.8	50	0.8	●
10060	6.0	6	131.0	76	81.0	50	1.0	●
10070	7.0	7	141.1	86	91.1	50	1.1	●
10080	8.0	8	156.3	98	106.3	50	1.3	●
10090	9.0	9	171.4	108	116.4	55	1.4	●
10100	10.0	10	191.6	123	131.6	60	1.6	●
15040	4.0	4	125.6	70	75.6	50	0.6	●
15050	5.0	5	140.8	85	90.8	50	0.8	●
15060	6.0	6	161.0	106	111.0	50	1.0	●
15070	7.0	7	176.1	121	126.1	50	1.1	●
15080	8.0	8	196.3	138	146.3	50	1.3	●
15090	9.0	9	221.4	153	161.4	60	1.4	●
15100	10.0	10	241.6	173	181.6	60	1.6	●
20040	4.0	4	140.6	85	90.6	50	0.6	●
20050	5.0	5	165.8	110	115.8	50	0.8	●
20060	6.0	6	191.0	136	141.0	50	1.0	●
20070	7.0	7	211.1	156	161.1	50	1.1	●
20080	8.0	8	231.3	173	181.3	50	1.3	●
20090	9.0	9	266.4	198	206.4	60	1.4	●
20100	10.0	10	286.6	218	226.6	60	1.6	●

●: Стандартная позиция



SHO...-M



Монолитное твердосплавное сверло для отверстий под резьбу

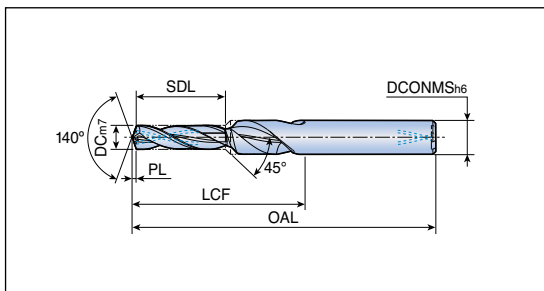

Обозначение	ISO резьба	Размеры (мм)						Сплав	
		DC	OAL	SDL	LCF	DCONMS	PL	ТТ9030	
SHO 033x12x6-M4	M4	3.3	62.5	12	26.5	6	0.5	●	
042x15x6-M5	M5	4.2	66.6	15	28.6	6	0.6	●	
050x18x8-M6	M6	5.0	79.8	18	36.8	8	0.8	●	
068x24x10-M8	M8	6.8	91.0	24	49.0	10	1.0	●	
085x30x12-M10	M10	8.5	103.3	30	56.3	12	1.3	●	



●: Стандартная позиция

Монолитное твердосплавное сверло для композитных материалов

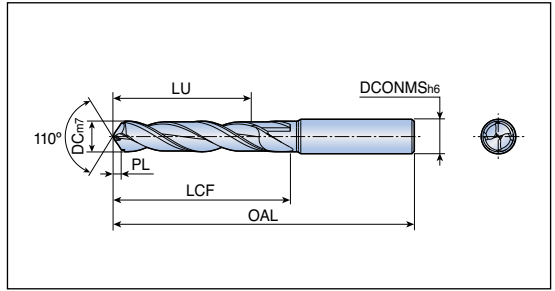

Обозначение	Размеры (мм)							Сплав
	DC (мм)	DC (дюйм)	DCONMS	OAL	LU	LCF	PL	TTD610
CDF 030-027-06	3	-	6	72.7	28	34.7	0.7	●
040-027-06	4	-	6	73.0	28	35.0	1.0	●
0476-034-06	4.76	3/16	6	81.3	35	43.3	1.3	●
050-034-06	5	-	6	81.3	35	43.3	1.3	●
060-034-06	6	-	6	81.7	36	43.7	1.7	●
0635-040-08	6.35	-	8	89.7	42	51.7	1.7	●
070-040-08	7	-	8	89.9	42	51.9	1.9	●
0794-040-08	7.94	5/16	8	90.2	42	52.2	2.2	●
080-040-08	8	-	8	90.2	42	52.2	2.2	●
090-045-10	9	-	10	101.5	48	59.5	2.5	●
0952-045-10	9.52	3/8	10	101.6	48	59.6	2.6	●
100-045-10	10	-	10	101.8	48	59.8	2.8	●
110-052-12	11	-	12	117.1	55	70.1	3.1	●
1111-052-12	11.11	7/16	12	117.1	55	70.1	3.1	●
120-052-12	12	-	12	117.4	55	70.4	3.4	●
127-055-14	12.7	1/2	14	122.6	59с	75.6	3.6	●



●: Стандартная позиция

T-CHAMFER...T1

TCHAMFER

Инструмент для обработки фаски со сменным монокристаллическим твердосплавным сверлом

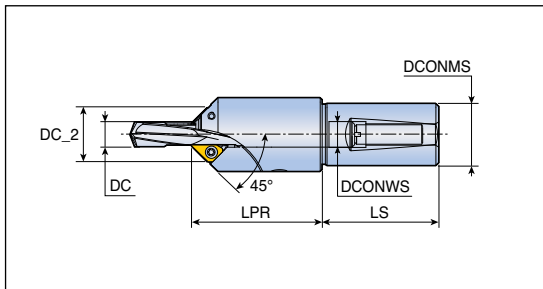

Обозначение	DC	Размеры (мм)					Пластина
		DCONWS	DC_2	DCONMS	LPR	LS	
T-CHAMFER 080-20T1-06	7.1-8.0	8	18.8	20	47.4	50	XCGT 06...C..
090-20T1-06	8.1-9.0	9	19.8	20	47.4	50	D167
100-32T1-09	9.1-10.0	10	24.9	32	67.3	60	XCGT 09...C..
110-32T1-09	10.1-11.0	11	25.9	32	67.3	60	D167
120-32T1-09	11.1-12.0	12	26.9	32	67.3	60	
130-32T1-09	12.1-13.0	13	27.9	32	67.3	60	
140-32T1-09	13.1-14.0	14	28.4	32	67.3	60	
150-32T1-09	14.1-15.0	15	29.4	32	67.3	60	
160-32T1-09	15.1-16.0	16	30.4	32	67.3	60	
170-32T1-09	16.1-17.0	17	31.4	32	67.3	60	
180-32T1-09	17.1-18.0	18	32.4	32	67.3	60	
190-32T1-09	18.1-19.0	19	33.4	32	75.0	60	
200-32T1-09	19.1-20.0	20	34.4	32	75.0	60	

Комплектующие

Обозначение	Боковой винт	Задний винт	Ключ	Винт	Ключ
T-CHAMFER 080 - 090	SS M6x1x6	M6x1-SP	L-W 3	TS 25064I	TD 8
T-CHAMFER 100 - 200	SS M10x1.5x10	M10x1.5-SP	L-W 5	TS 40093I	TD 15



Монолитное твердосплавное сверло для T-CHAMFER

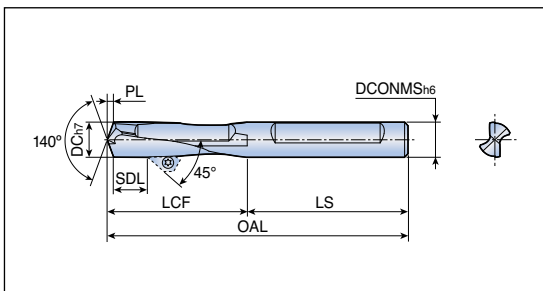

Обозначение	Размеры (мм)								Сплав
	DC	DCONMS	OAL	LCF	LS	SDL _{min}	SDL _{max}	PL	
SHD 3080-CF	8.0	8.0	80.3	37.3	43	9.5	17.5	1.3	●
3090-CF	9.0	9.0	85.4	42.4	43	13.0	23.5	1.4	●
3100-CF	10.0	10.0	90.6	47.6	43	15.5	25.0	1.6	●
3110-CF	11.0	11.0	96.8	53.8	43	21.5	30.0	1.8	●
3120-CF	12.0	12.0	103.9	60.9	43	25.5	37.0	1.9	●
3130-CF	13.0	13.0	104.1	61.1	43	25.5	35.0	2.1	●
3150-CF	15.0	15.0	113.4	65.4	48	26.5	40.5	2.4	●
3170-CF	17.0	17.0	121.7	71.7	50	24.5	44.0	2.7	●
3180-CF	18.0	18.0	125.9	75.9	50	26.5	48.0	2.9	●
3190-CF	19.0	19.0	130.0	76	54	26.5	49.0	3.0	●

- Параметр 'L3' рассчитан с учетом пластины 45°, расположенной в кармане
- Монолитные сверла с внутренними каналами СОЖ доступны по запросу
- Стандартная позиция

Пластина	Угол фаски (°)	Размер фаски
XCGT 0603-C30	30°	1.5
0603-C45	45°	4.5
0603-C60	60°	2.5
XCGT 0903-C30	30°	1.5
0903-C45	45°	6.0
0903-C60	60°	3.5

- Максимальный размер фаски получается при использовании сверла минимального диаметра

TCAP...-2.25DN



Многофункциональный инструмент - 2.25xD



- Внутренняя подача СОЖ

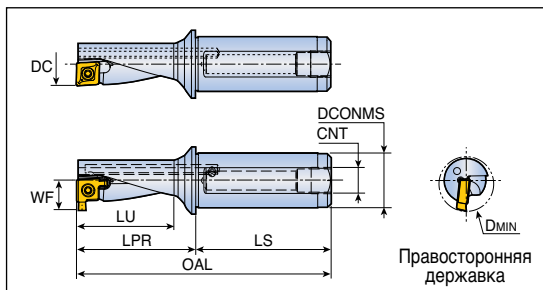
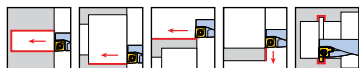

Обозначение	Размеры (мм)								Пластина	
	DC	DCONMS	WF	LU	LPR	LS	DMIN	CNT	Для сверления и токарной обработки	Для обработки канавок
TCAP 08R/L-2.25DN	8	12	-	18.0	22.5	42	-	G 1/16	XCM(G)T 04...TC/TA	-
10R/L-2.25DN-GV	10	12	7.1	22.5	27.5	42	12.0	G 1/16	XCM(G)T 05...TC/TA	XCMT 05R...GV
12R/L-2.25DN-GV	12	16	8.5	27.0	33.0	45	14.5	G 1/8	XCM(G)T 06...TC/TA	XCMT 06R...GV
14R/L-2.25DN-GV	14	16	9.5	31.5	38.5	45	16.5	G 1/8	XCM(G)T 07...TC/TA	XCMT 07R...GV
16R/L-2.25DN-GV	16	20	11.1	36.0	44.0	50	19.0	G 1/8	XCM(G)T 08...TC/TA	XCMT 08R...GV
20R/L-2.25DN-GV	20	25	13.2	45.0	55.0	56	23.5	G 1/8	XCM(G)T 10...TC/TA	XCMT 10R...GV
25R/L-2.25DN-GV	25	32	16.5	56.2	69.0	61	29.0	G 1/8	XCM(G)T 13...TC/TA	XCMT 13R...GV
32R/L-2.25DN-GV	32	40	20.5	72.0	86.0	74	36.5	G 1/8	XCM(G)T 17...TC/TA	XCMT 17R...GV
									D168-169	D168

- $OAL = LPR + LS$
- Доступна правосторонняя канавочная пластина

Комплектующие

Обозначение	Винт	Ключ	
TCAP 08	TS 18034I/HG-P	T 6P	
TCAP 10	TS 20038I/HG-P	T 6P	
TCAP 12	TS 22052I/HG-P	T 7P	
TCAP 14	TS 25064I/HG-P	T 8P	
TCAP 16	TS 30100I/HG-P		TD 9P
TCAP 20	TS 35088I/HG-P		TD10P
TCAP 25	TS 45A100I/HG		TD 20
TCAP 32	TS 45A100I/HG		TD 20



TCAP...-3.0DN



Многофункциональный инструмент - 3.0xD



- Внутренняя подача СОЖ

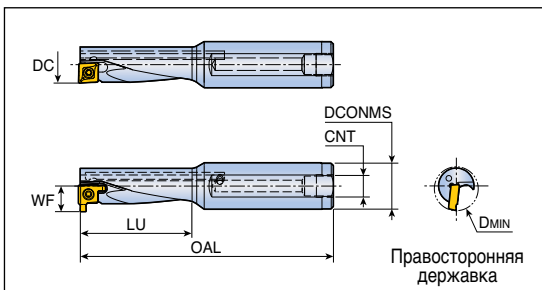
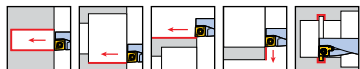

Обозначение	Размеры (мм)							Пластина	
	DC	DCONMS	WF	LU	OAL	DMIN	CNT	Для сверления и токарной обработки	Для обработки канавок
TCAP 08R/L-3.0DN12	8	12	-	24	80	-	G 1/16	XCM(G)T 04...TC/TA	-
10R/L-3.0DN-GV	10	12	7.1	30	85	12.0	G 1/16	XCM(G)T 05...TC/TA	XCMT 05R...GV
12R/L-3.0DN-GV	12	16	8.5	36	95	14.5	G 1/8	XCM(G)T 06...TC/TA	XCMT 06R...GV
14R/L-3.0DN-GV	14	16	9.5	42	100	16.5	G 1/8	XCM(G)T 07...TC/TA	XCMT 07R...GV
16R/L-3.0DN-GV	16	20	11.1	48	110	19.0	G 1/8	XCM(G)T 08...TC/TA	XCMT 08R...GV
20R/L-3.0DN-GV	20	25	13.2	60	130	23.5	G 1/8	XCM(G)T 10...TC/TA	XCMT 10R...GV
25R/L-3.0DN-GV	25	32	16.5	75	150	29.0	G 1/8	XCM(G)T 13...TC/TA	XCMT 13R...GV
32R/L-3.0DN-GV	32	40	20.5	96	185	36.5	G 1/8	XCM(G)T 17...TC/TA	XCMT 17R...GV
								D168-169	D168

- OAL = LPR + LS
- Доступна правосторонняя канавочная пластина

Комплектующие

Обозначение	Винт	Ключ	
TCAP 08	TS 18034I/HG-P	T 6P	
TCAP 10	TS 20038I/HG-P	T 6P	
TCAP 12	TS 22052I/HG-P	T 7P	
TCAP 14	TS 25064I/HG-P	T 8P	
TCAP 16	TS 30100I/HG-P		TD 9P
TCAP 20	TS 35088I/HG-P		TD10P
TCAP 25	TS 45A100I/HG		TD 20
TCAP 32	TS 45A100I/HG		TD 20



Расточные державки с пластинами TOPCAP



- Для растачивания
- Наружная подача СОЖ

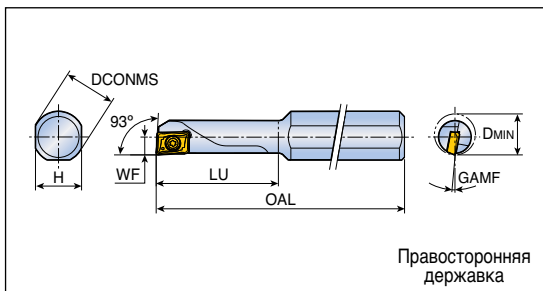
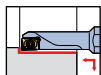

Обозначение	Размеры (мм)							Пластина
	DCONMS	H	OAL	LU	WF	DMIN	GAMF	
S10H SXUCR/L 04-06 ⁽¹⁾	10	9	100	21	3.0	6	9°	XCMT 04...R/L TC
S10J SXUCR/L 04-07 ⁽¹⁾	10	9	110	24.5	3.5	7	5°	D169
S10J SXUCR/L 04-08 ⁽¹⁾	10	9	110	28	4.0	8	2°	
S10K SXUCR/L 05-10	10	9	125	35	5.0	10	2°	XCMT 05..TC D169

⁽¹⁾Правосторонние пластины необходимо применять с правосторонними расточными державками

Комплектующие

Обозначение	Винт	Ключ		
S10H SXUCR/L 04-06	TS 18034I/HG-P	T 6P		
S10J SXUCR/L 04-07	TS 18034I/HG-P	T 6P		
S10J SXUCR/L 04-08	TS 18034I/HG-P	T 6P		
S10K SXUCR/L 05-10	TS 20038I/HG-P	T 6P		



Зажимной элемент (Система выравнивания по центру)

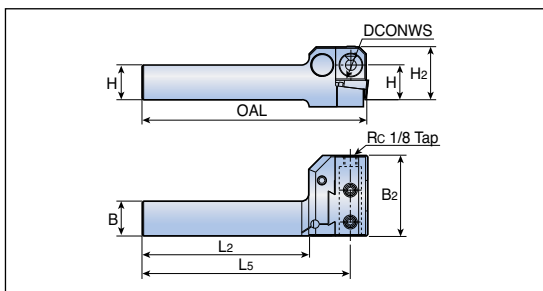

Обозначение	Размеры (мм)								Державка
	H	B	DCONWS	H2	B2	L2	L5	OAL	
TGHR 2020-D16	20	20	16	38	58	120	150	161	TCAP 08R/L...
2525-D16	25	25	16	38	58	120	150	161	TCAP 10R/L...
									TCAP 12R/L...
									TCAP 14R/L...
2525-D25	25	25	25	56	75	120	157	174	TCAP 16R/L...
									TCAP 20R/L...

Комплектующие

Обозначение	Блок	Клин	Стопорное кольцо	Винт клина	Установочный штифт	Винт установочного штифта	Крепёжный винт		Стопорный винт	Ключ
TGHR 2020-D16	TGHR-D16-BL	TGHR-WD	WSR 4	TGH-WS	TGH-MPI	TGH-MPS	SSxM8 1.25X10-C	SSxM8 x1.25x8	-	L-W 4
TGHR 2525-D16										
TGHR 2525-D25	TGHR-D25-BL	TGHR-WD-25	WSR 4	TGH-WS-25	TGH-MPI-25	TGH-MPS-25	SS M10 x1.5x12-C	SS M101.5x10	SH M6x1x20	L-W 4 L-W 5

Втулка для зажимного элемента

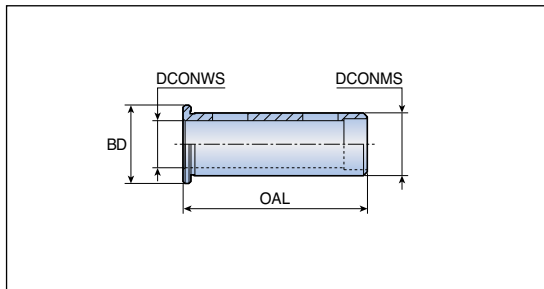

Обозначение	Размеры (мм)				Державка
	DCONMS	DCONWS	BD	OAL	
TSL 16-12	16	12	20	47	TCAP 10R/L...
25-20	25	20	32	55	TCAP 16R/L...

TBSL

Втулка для расточной державки

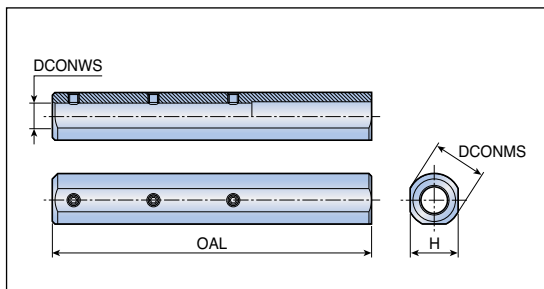

Обозначение	Размеры (мм)			
	DCONMS	DCONWS	OAL	H
TBSL 20-10-120	20	10	120	18

Комплектующие

Обозначение	Винт	Ключ		
TBSL 20-10-120	SS M4x0.7x4	L-W 2		

Инструмент для глубокого сверления



Однотрубная система

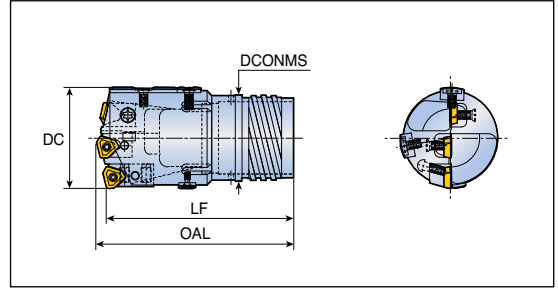

- Наружная четырехзаходная резьба

Обозначение	DC	Размеры (мм)			Труба	
		LF	OAL	DCONMS	Обозначение	Диаметр (мм)
TBTA3-xxx.xxSE4-33	38.00-39.60	85	90	30	BTSI 033	33
xxx.xxSE4-36	39.61-43.00	85	91	33	BTSI 036	36
xxx.xxSE4-39	43.01-47.00	95	101	36	BTSI 039	39
xxx.xxSE4-43	47.01-51.70	95	102	39	BTSI 043	43
xxx.xxSE4-47	51.71-56.20	100	107	43	BTSI 047	47
xxx.xxSE4-51	56.21-60.60	110	118	47	BTSI 051	51
xxx.xxSE4-56A	60.61-64.99	110	119	51	BTSI 056A	56
xxx.xxSE4-56B	65.00-66.99	150	159	52	BTSI 056B	56
xxx.xxSE4-62	67.00-72.99	150	159	58	BTSI 062	62
xxx.xxSE4-68	73.00-79.99	150	160	63	BTSI 068	68
xxx.xxSE4-75	80.00-86.99	180	191	70	BTSI 075	75
xxx.xxSE4-82	87.00-99.99	180	193	77	BTSI 082	82
xxx.xxSE4-94	100.00-106.99	180	193	89	BTSI 094	94

Комплекующие: D98, Труба: D130, Условия резания: D202

TBTA3...S11



Однотрубная система

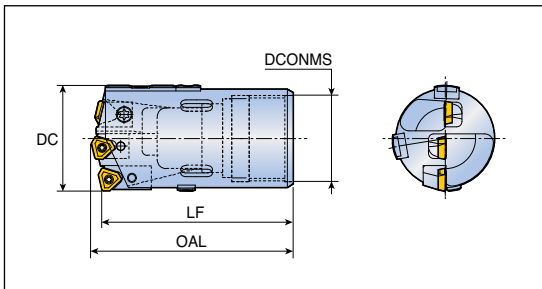

- Внутренняя однозаходная резьба

Обозначение	DC	Размеры (мм)			Труба	
		LF	OAL	DCONMS	Обозначение	Диаметр (мм)
TBTA3- xxx.xxS11-33	38.00-39.99	80	85	30	BTSE 033	33
xxx.xxS11-36	40.00-43.99	80	86	33	BTSE 036	36
xxx.xxS11-39	44.00-46.99	90	96	37	BTSE 039	39
xxx.xxS11-43	47.00-51.99	90	97	41	BTSE 043	43
xxx.xxS11-47	52.00-56.99	100	107	44	BTSE 047	47
xxx.xxS11-51	57.00-60.99	110	118	49	BTSE 051	51
xxx.xxS11-56	61.00-67.99	110	119	53	BTSE 056	56
xxx.xxS11-62	68.00-74.99	120	129	59	BTSE 062	62
xxx.xxS11-68	75.00-80.99	150	161	65	BTSE 068	68
xxx.xxS11-75	81.00-90.99	150	162	71	BTSE 075	75
xxx.xxS11-82	91.00-98.99	150	162	79	BTSE 082	82
xxx.xxS11-94	99.00-106.99	150	163	90	BTSE 094	94

Комплектуемые D98	Труба D130	Условия резания D202
----------------------	---------------	-------------------------

TBTA3...DE4

Двухтрубная система

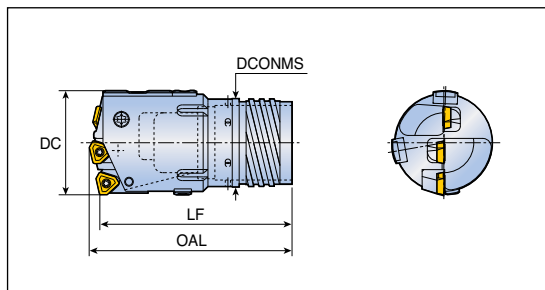

- Наружная четырехзаходная резьба

Обозначение	DC	Размеры (мм)			Труба		
		LF	OAL	DCONMS	Наружная труба	Внутренняя труба	Диаметр (мм)
TBTA3-xxx.xxDE4-35.5	38.00-39.60	85	90	33	BTDO 035.5	BTDI 026	35.5
xxx.xxDE4-39	39.61-43.00	85	91	36	BTDO 039	BTDI 029	39.0
xxx.xxDE4-42.5	43.01-47.00	95	101	39	BTDO 042.5	BTDI 032	42.5
xxx.xxDE4-46.5	47.01-51.70	100	102	43	BTDO 046.5	BTDI 035	46.5
xxx.xxDE4-51	51.71-56.20	100	107	47	BTDO 051	BTDI 039	51.0
xxx.xxDE4-55.5	56.21-65.00	110	119	51	BTDO 055.5	BTDI 043A	55.5
xxx.xxDE4-56	65.00-66.99	150	159	52	BTDO 056	BTDI 043B	56.0
xxx.xxDE4-62	67.00-72.99	150	159	58	BTDO 062	BTDI 048	62.0
xxx.xxDE4-68	73.00-79.99	150	160	63	BTDO 068	BTDI 053	68.0
xxx.xxDE4-75	80.00-86.99	180	191	70	BTDO 075	BTDI 059	75.0
xxx.xxDE4-82	87.00-99.99	180	193	77	BTDO 082	BTDI 066	82.0
xxx.xxDE4-94	100.00-106.99	180	193	89	BTDO 094	BTDI 078	94.0

Комплектующие  D98	Труба  D130	Условия резания  D202
--	--	--

Комплектующие серии ТВТА3

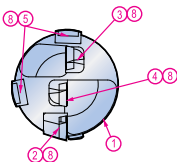
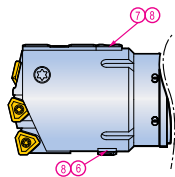

1. Корпус головки
2. Наружный картридж
3. Внутренний картридж
4. Центральный картридж
5. Направляющая пластина
6. Дополнительная направляющая пластина
7. Щиток направляющей пластины
8. Стопорный винт

Комплектующие		Диаметр (мм)				
		38.00-39.99	40.00-44.99	45.00-47.99	48.00-51.99	52.00-54.99
Картридж	Наружный	PERC 05R	PERC 402-04	PERC 402-04	PERC 402-04	PERC 402-32
	Регулировочный винт	AS0003-5	AS0004-8	AS0004-8	AS0004-8	AS0005-10
	Ключ	H1.5	H2	H2	H2	H2.5
	Винт	LS1803RH	LS1803.5RH	LS1803.5RH	LS1803.5RH	LS1805RH
	Ключ	H2	H2.5	H2.5	H2.5	H3
	Внутренний	CENC 05R	CENC 05R	CENC 05R	CENC 402-04	CENC 402-04
	Винт	CSTB3	CSTB3	CSTB3	CSTB3.5	CSTB3.5
	Ключ	T-9D	T-9D	T-9D	T-15D	T-15D
	Центральный	CENC 05R	CENC 05R	CENC 402-04	CENC 402-04	CENC 402-04
	Винт	CSTB3	CSTB3	CSTB3.5	CSTB3.5	CSTB3.5
Ключ	T-9D	T-9D	T-15D	T-15D	T-15D	
Пластина	Наружный	NPMX 0803RG	TPMX 1403RG	TPMX 1403RG	TPMX 1403RG	TPMX 1704RG
	Винт	CSTB2.2	CSTB2.5	CSTB2.5	CSTB2.5	CSTB3.5D
	Ключ	T-7D	T-8D	T-8D	T-8D	T-9D
	Внутренний	NPMX 0803RG	NPMX 0803RG	NPMX 0803RG	TPMX 1403RG	TPMX 1403RG
	Винт	CSTB2.2	CSTB2.2	CSTB2.2	CSTB2.5	CSTB2.5
	Ключ	T-7D	T-7D	T-7D	T-8D	T-8D
Направляющая пластина	Направляющая пластина	PAD-GO08CD-SA-FB	PAD-GO08CD-SA-FB	PAD-GC10-SA	PAD-GC10-SA	PAD-GC10-SA
	Винт	PAD-GO08CD-SB-FB	PAD-GO08CD-SB-FB	PAD-GC10-SB	PAD-GC10-SB	PAD-GC10-SB
	Ключ	CSTB3S	CSTB3S	CSTB4S	CSTB4S	CSTB4S
	Ключ	T-9D	T-9D	T-15D	T-15D	T-15D
	Щиток направляющей пластины	PAD-P08	PAD-P08	PAD-P10	PAD-P10	PAD-P10
	Винт	CSTB3S	CSTB3S	CSTB4S	CSTB4S	CSTB4S
	Ключ	T-9D	T-9D	T-15D	T-15D	T-15D
	Дополнительная направляющая пластина	PAD-S08	PAD-S08	PAD-S08	PAD-S08	PAD-S08
	Винт	CSTB3S	CSTB3S	CSTB3S	CSTB3S	CSTB3S
	Ключ	T-9D	T-9D	T-9D	T-9D	T-9D



Комплектующие серии ТВТА3

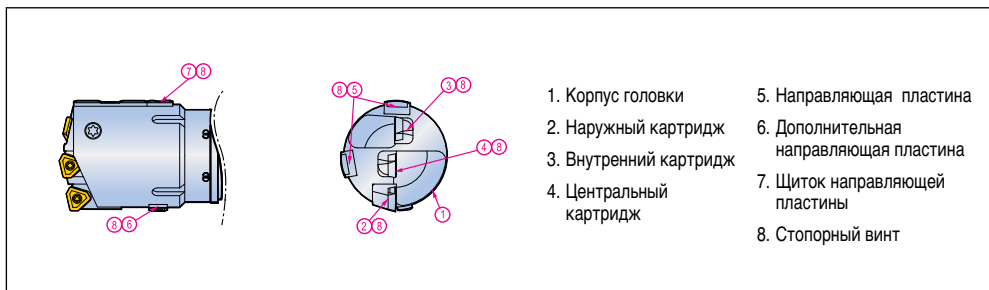

1. Корпус головки
2. Наружный картридж
3. Внутренний картридж
4. Центральный картридж
5. Направляющая пластина
6. Дополнительная направляющая пластина
7. Щиток направляющей пластины
8. Стопорный винт

Комплектующие		Диаметр (мм)				
		55.00-57.99	58.00-59.99	60.00-63.99	64.00-67.99	68.00-77.99
Картридж	Наружный	PERC 402-32	PERC 402-32	PERC 402-32	PERC 402-43	PERC 402-32
	Регулировочный винт	AS0005-10	AS0005-10	AS0005-10	AS0005-15	AS0005-10
	Ключ	H2.5	H2.5	H2.5	H2.5	H2.5
	Винт	LS1805RH	LS1805RH	LS1805RH	LS1806RH	LS1805RH
	Ключ	H3	H3	H3	H4	H3
	Внутренний	CENC 402-04	CENC 402-32	CENC 402-32	CENC 402-32	CENC 402-43
	Винт	CSTB3.5	CSTA5	CSTA5	CSTA5	LS1206
	Ключ	T-15D	T-15D	T-15D	T-15D	H3
	Центральный	CENC 402-32	CENC 402-32	CENC 402-32	CENC 402-32	CENC 402-43
	Винт	CSTA5	CSTA5	CSTA5	CSTA5	LS1206
Пластина	Ключ	T-15D	T-15D	T-15D	T-15D	H3
	Наружный	TPMX 1704RG	TPMX 1704RG	TPMX 1704RG	TPMX 2405RG	TPMX 1704RG
	Винт	CSTB3.5D	CSTB3.5D	CSTB3.5D	CSTB4M	CSTB3.5D
	Ключ	T-9D	T-9D	T-9D	T-15D	T-9D
	Внутренний	TPMX 1403RG	TPMX 1704RG	TPMX 1704RG	TPMX 1704RG	TPMX 2405RG
	Винт	CSTB2.5	CSTB3.5D	CSTB3.5D	CSTB3.5D	CSTB4M
	Ключ	T-8D	T-9D	T-9D	T-9D	T-15D
	Центральный	TPMX 1704RG	TPMX 1704RG	TPMX 1704RG	TPMX 1704RG	TPMX 2405RG
	Винт	CSTB3.5D	CSTB3.5D	CSTB3.5D	CSTB3.5D	CSTB4M
	Ключ	T-9D	T-9D	T-9D	T-9D	T-15D
Направляющая пластина	Направляющая пластина	PAD-GC10-SA	PAD-GC10-SA	PAD-GC14-SB	PAD-GC14-SB	PAD-GC14-SB
	Винт	PAD-GC10-SB	PAD-GC10-SB	-	-	-
	Ключ	CSTB4S	CSTB4S	CSTA5S	CSTA5S	CSTA5S
	Ключ	T-15D	T-15D	T-15D	T-15D	T-15D
	Щиток направляющей пластины	PAD-P10	PAD-P10	PAD-P14	PAD-P14	PAD-P14
	Винт	CSTB4S	CSTB4S	CSTA5S	CSTA5S	CSTA5S
	Ключ	T-15D	T-15D	T-15D	T-15D	T-15D
	Дополнительная направляющая пластина	PAD-S08	PAD-S08	PAD-S08	PAD-S10	PAD-S10
	Винт	CSTB3S	CSTB3S	CSTB3S	CSTB3S	CSTB3S
	Ключ	T-9D	T-9D	T-9D	T-9D	T-9D



Комплектующие серии ТВТА3

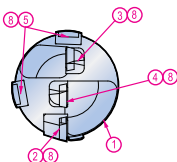
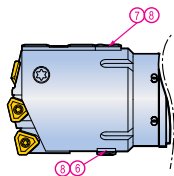

1. Корпус головки
2. Наружный картридж
3. Внутренний картридж
4. Центральный картридж
5. Направляющая пластина
6. Дополнительная направляющая пластина
7. Щиток направляющей пластины
8. Стопорный винт

Комплектующие		Диаметр (мм)			
		78.00-84.99	85.00-91.99	92.00-98.99	99.00-106.99
Картридж	Наружный	PERC 402-43	PERC 402-63	PERC 402-43	PERC 402-63
	Регулировочный винт	AS0005-15	AS0006-15	AS0005-15	AS0006-15
	Ключ	H2.5	H3	H2.5	H3
	Винт	LS1806RH	LS1806RH	LS1806RH	LS1806RH
	Ключ	H4	H4	H4	H4
	Внутренний	CENC 402-43	CENC 402-43	CENC 402-63	CENC 402-63
	Винт	LS1206	LS1206	LS1206	LS1206
	Ключ	H3	H3	H3	H3
	Центральный	CENC 402-43	CENC 402-43	CENC 402-63	CENC 402-63
	Винт	LS1206	LS1206	LS1206	LS1206
Пластина	Ключ	H3	H3	H3	H3
	Наружный	TPMX 2405RG	TPMX 2807RG	TPMX 2405RG	TPMX 2807RG
	Винт	CSTB4M	CSTB5	CSTB4M	CSTB5
	Ключ	T-15D	T-20D	T-15D	T-20D
	Внутренний	TPMX 2405RG	TPMX 2405RG	TPMX 2807RG	TPMX 2807RG
	Винт	CSTB4M	CSTB4M	CSTB5	CSTB5
	Ключ	T-15D	T-15D	T-20D	T-20D
Направляющая пластина	Центральный	TPMX 2405RG	TPMX 2405RG	TPMX 2807RG	TPMX 2807RG
	Винт	CSTB4M	CSTB4M	CSTB5	CSTB5
	Ключ	T-15D	T-15D	T-20D	T-20D
	Направляющая пластина	PAD-GC14-SB	PAD-GC14-SB	PAD-GC14-SB	PAD-GC18-SB
	Винт	CSTA5S	CSTA5S	CSTA5S	LS1206S
	Ключ	T-15D	T-15D	T-15D	H3
	Щиток направляющей пластины	PAD-P14	PAD-P14	PAD-P14	PAD-P18
	Винт	CSTB5S	CSTB5S	CSTA5S	LS1206S
	Ключ	T-15D	T-15D	T-15D	H3
	Дополнительная направляющая пластина	PAD-S10	PAD-S10	PAD-S10	PAD-S14
Винт	CSTB3S	CSTB3S	CSTB3S	CSTA5S	
Ключ	T-9D	T-9D	T-9D	T-15D	



TBTA5...SE4



Однотрубная система

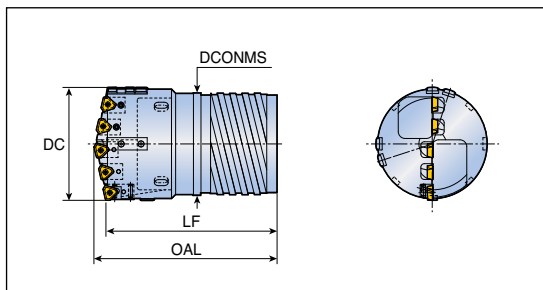

- Наружная четырехзачодная резьба

Обозначение	DC	Размеры (мм)			Труба	
		LF	OAL	DCONMS	Обозначение	Диаметр (мм)
TBTA5- xxx.xxSE4-094	107.00-111.99	180	197	89	BTSI 094	94
xxx.xxSE4-106	112.00-123.99	205	221	101	BTSI 106	106
xxx.xxSE4-118	124.00-135.99	205	222	113	BTSI 118	118
xxx.xxSE4-130	136.00-147.99	205	223	125	BTSI 130	130
xxx.xxSE4-142	148.00-159.99	225	245	137	BTSI 142	142
xxx.xxSE4-154	160.00-168.99	225	246	149	BTSI 154	154

TBTA5...SI1



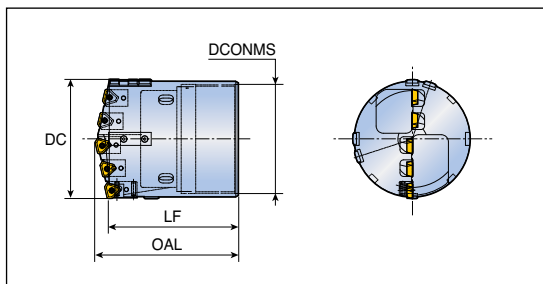

Однотрубная система



- Внутренняя однозачодная резьба

Обозначение	DC	Размеры (мм)			Труба	
		LF	OAL	DCONMS	Обозначение	Диаметр (мм)
TBTA5- xxx.xxSI1-094	107.00-110.99	150	164	90	BTSE 094	94
xxx.xxSI1-106	111.00-122.99	150	165	102	BTSE 106	106
xxx.xxSI1-118	123.00-134.99	150	167	114	BTSE 118	118
xxx.xxSI1-130	135.00-148.99	150	168	126	BTSE 130	130
xxx.xxSI1-142	149.00-161.99	150	170	139	BTSE 142	142
xxx.xxSI1-154	162.00-168.99	190	211	151	BTSE 154	154

Комплектующие  D103	Труба  D130	Условия резания  D202
---	--	--



Двухтрубная система

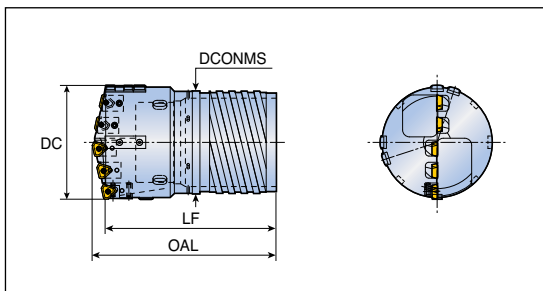

- Наружная четырехзаходная резьба

Обозначение	DC	Размеры (мм)			Труба		
		LF	OAL	DCONMS	Наружная труба	Внутренняя труба	Диаметр (мм)
TBTA5 - xxx.xxDE4-094	107.00-111.99	180	197	89	BTDO 094	BTDI 078	94
xxx.xxDE4-106	112.00-123.99	205	221	101	BTDO 106	BTDI 090	106
xxx.xxDE4-118	124.00-135.99	205	222	113	BTDO 118	BTDI 092	118
xxx.xxDE4-130	136.00-147.99	205	223	125	BTDO 130	BTDI 093	130
xxx.xxDE4-142	148.00-159.99	225	245	137	BTDO 142	BTDI 094	142
xxx.xxDE4-154	160.00-168.99	225	246	149	BTDO 154	BTDI 095	154

Комплектующие

 D103

Труба

 D130

Угловая резания

 D202

Комплектующие серии ТВТА5

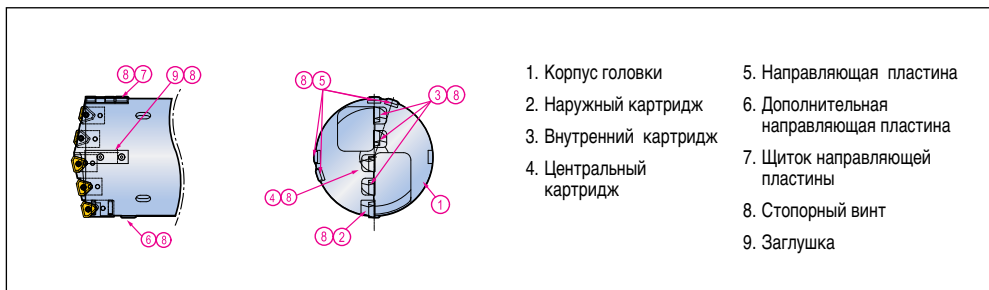

Комплектующие		Диаметр (мм)			
		107.00-117.99	118.00-135.99	136.00-144.99	145.00-150.99
Картридж	Наружный	PERC 402-43	PERC 402-43	PERC 402-43	PERC 402-43
	Регулировочный винт	AS0005-15	AS0005-15	AS0005-15	AS0005-15
	Ключ	H2.5	H2.5	H2.5	H2.5
	Винт	LS1806RH	LS1806RH	LS1806RH	LS1806RH
	Ключ	H4	H4	H4	H4
	Внутренний	CENC 402-32	CENC 402-43	CENC 402-43	CENC 402-43
	Винт	CSTA5	LS1206	LS1206	LS1206
	Ключ	T-15D	H3	H3	H3
	Центральный	CENC 402-43	CENC 402-43	CENC 402-63	CENC 402-63
	Винт	LS1206	LS1206	LS1206	LS1206
Пластина	Ключ	H3	H3	H3	H3
	Наружный	TPMX 2405RG	TPMX 2405RG	TPMX 2405RG	TPMX 2405RG
	Винт	CSTB4M	CSTB4M	CSTB4M	CSTB4M
	Ключ	T-15D	T-15D	T-15D	T-15D
	Внутренний	TPMX 1704RG	TPMX 2405RG	TPMX 2405RG	TPMX 2405RG
	Винт	CSTB3.5D	CSTB4M	CSTB4M	CSTB4M
	Ключ	T-9D	T-15D	T-15D	T-15D
Направляющая пластина	Центральный	TPMX 2405RG	TPMX 2405RG	TPMX 2807RG	TPMX 2807RG
	Винт	CSTB4M	CSTB4M	CSTB5	CSTB5
	Ключ	T-15D	T-15D	T-20D	T-20D
	Направляющая пластина	PAD-GC18-SB	PAD-GC18-SB	PAD-GC18-SB	PAD-GC18-SB
	Винт	LS1206S	LS1206S	LS1206S	LS1206S
	Ключ	H3	H3	H3	H3
	Щиток направляющей пластины	PAD-P18	PAD-P18	PAD-P18	PAD-P18
	Винт	LS1206S	LS1206S	LS1206S	LS1206S
	Ключ	H3	H3	H3	H3
	Дополнительная направляющая пластина	PAD-S14	PAD-S14	PAD-S14	PAD-S14
	Винт	CSTA5S	CSTA5S	CSTA5S	CSTA5S
	Ключ	T-15D	T-15D	T-15D	T-15D



Комплектующие серии ТВТА5

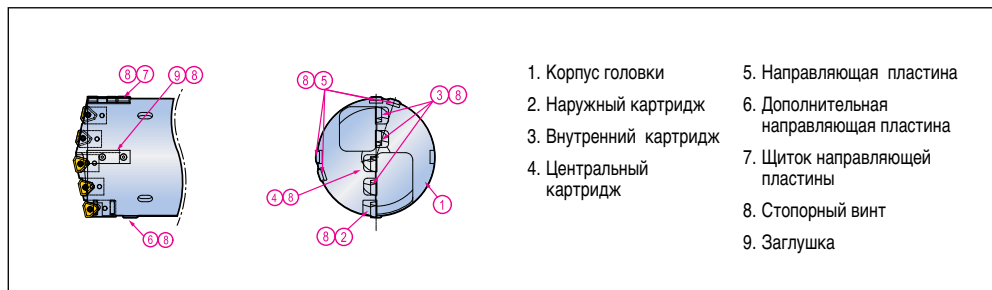

Комплектующие		Диаметр (мм)		
		151.00-156.99	157.00-162.99	163.00-168.99
Картридж	Наружный	PERC 402-63	PERC 402-63	PERC 402-63
	Регулировочный винт	AS0006-15	AS0006-15	AS0006-15
	Ключ	H3	H3	H3
	Винт	LS1806RH	LS1806RH	LS1806RH
	Ключ	H4	H4	H4
	Внутренний	CENC 402-43	CENC 402-43	CENC 402-63
	Винт	LS1206	LS1206	LS1206
	Ключ	H3L	H3L	H3L
	Центральный	CENC 402-63	CENC 402-63	CENC 402-63
	Винт	LS1206S	LS1206S	LS1206S
Пластина	Ключ	H3L	H3L	H3L
	Наружный	TPMX 2807RG	TPMX 2807RG	TPMX 2807RG
	Винт	CSTB5	CSTB5	CSTB5
	Ключ	T-20D	T-20D	T-20D
	Внутренний	TPMX 2405RG	TPMX 2405RG	TPMX 2807RG
	Винт	CSTB4M	CSTB4M	CSTB5
	Ключ	T-15D	T-15D	T-20D
	Центральный	TPMX 2807RG	TPMX 2807RG	TPMX 2807RG
Направляющая пластина	Винт	CSTB5	CSTB5	CSTB5
	Ключ	T-20D	T-20D	T-20D
	Направляющая пластина	PAD-GC18-SB	PAD-GC18-SB	PAD-GC18-SB
	Винт	LS1206S	LS1206S	LS1206S
	Ключ	H3	H3	H3L
	Щиток направляющей пластины	PAD-P18	PAD-P18	PAD-P18
	Винт	LS1206S	LS1206S	LS1206S
	Ключ	H3	H3	H3
	Дополнительная направляющая пластина	PAD-S14	PAD-S14	PAD-S14
	Винт	CSTA5S	CSTA5S	CSTA5S
Ключ	T-15D	T-15D	T-15D	



TBTA7...SE4



Однотрубная система

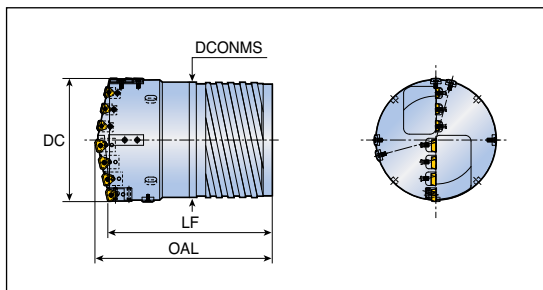

- Наружная четырехзаходная резьба
- Двухтрубная система доступна по запросу

Обозначение	DC	Размеры (мм)			Труба	
		LF	OAL	DCONMS	Обозначение	Диаметр (мм)
TBTA7- xxx.xxSE4-154	169.00-171.99	225	246	149	BTSI 154	154
xxx.xxSE4-166	172.00-183.99	225	247	161	BTSI 166	166
xxx.xxSE4-178	184.00-195.99	245	267	173	BTSI 178	178
xxx.xxSE4-190	196.00-207.99	245	270	185	BTSI 190	190
xxx.xxSE4-202	208.00-219.99	245	271	197	BTSI 202	202
xxx.xxSE4-214	220.00-231.99	265	293	208	BTSI 214	214
xxx.xxSE4-226	232.00-232.99	265	293	220	BTSI 226	226

TBTA7...SI1



Однотрубная система

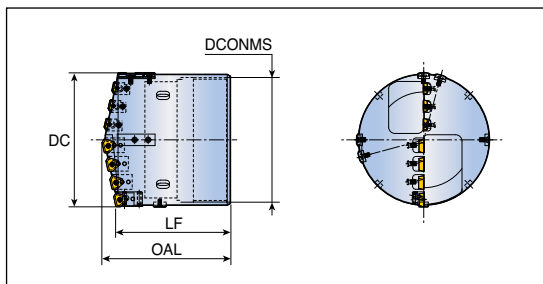

- Внутренняя однозаходная резьба

Обозначение	DC	Размеры (мм)			Труба	
		LF	OAL	DCONMS	Обозначение	Диаметр (мм)
TBTA7- xxx.xxSI1-154	169.00-173.99	190	211	151	BTSE 154	154
xxx.xxSI1-166	174.00-185.99	190	213	163	BTSE 166	166
xxx.xxSI1-178	186.00-197.99	190	212	175	BTSE 178	178
xxx.xxSI1-190	198.00-209.99	190	215	187	BTSE 190	190
xxx.xxSI1-202	210.00-221.99	190	217	199	BTSE 202	202
xxx.xxSI1-214	222.00-232.99	190	218	211	BTSE 214	214

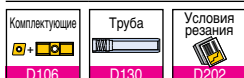

Комплектующие серии ТВТА7

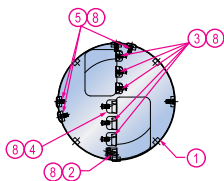
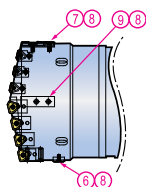

1. Корпус головки
2. Наружный картридж
3. Внутренний картридж
4. Центральный картридж
5. Направляющая пластина
6. Дополнительная направляющая пластина
7. Щиток направляющей пластины
8. Стопорный винт
9. Заглушка

Комплектующие		Диаметр (мм)			
		169.00-188.99	189.00-196.99	197.00-202.99	203.00-208.99
Картридж	Наружный	PERC 402-43	PERC 402-43	PERC 402-43	PERC 402-43
	Регулировочный винт	AS0005-15	AS0005-15	AS0005-15	AS0005-15
	Ключ	H2.5	H2.5	H2.5	H2.5
	Винт	LS1806RH	LS1806RH	LS1806RH	LS1806RH
	Ключ	H4	H4	H4	H4
	Внутренний	CENC 402-43	CENC 402-43	CENC 402-43	CENC 402-43
	Винт	LS1206	LS1206	LS1206	LS1206
	Ключ	H3L	H3L	H3L	H3L
	Центральный	CENC 402-43	CENC 402-63	CENC 402-63	CENC 402-63
	Винт	LS1206	LS1206S	LS1206S	LS1206S
Ключ	H3L	H3L	H3L	H3L	
Пластина	Наружный	TPMX 2405RG	TPMX 2405RG	TPMX 2405RG	TPMX 2405RG
	Винт	CSTB4M	CSTB4M	CSTB4M	CSTB4M
	Ключ	T-15D	T-15D	T-15D	T-15D
	Внутренний	TPMX 2405RG	TPMX 2405RG	TPMX 2405RG	TPMX 2405RG
	Винт	CSTB4M	CSTB4M	CSTB4M	CSTB4M
	Ключ	T-15D	T-15D	T-15D	T-15D
	Центральный	TPMX 2405RG	TPMX 2807RG	TPMX 2807RG	TPMX 2807RG
	Винт	CSTB4M	CSTB5	CSTB5	CSTB5
Ключ	T-15D	T-15D	T-15D	T-15D	
Направляющая пластина	Направляющая пластина	PAD-GC18-SB	PAD-GC18-SB	PAD-GC18-SB	PAD-GC18-SB
	Винт	LS1206S	LS1206S	LS1206S	LS1206S
	Ключ	H3	H3	H3	H3
	Щиток направляющей пластины	PAD-P18	PAD-P18	PAD-P18	PAD-P18
	Винт	LS1206S	LS1206S	LS1206S	LS1206S
	Ключ	H3	H3	H3	H3
	Дополнительная направляющая пластина	PAD-S14	PAD-S14	PAD-S14	PAD-S14
	Винт	CSTA5S	CSTA5S	CSTA5S	CSTA5S
	Ключ	T-15D	T-15D	T-15D	T-15D



Комплектующие серии ТВТА7

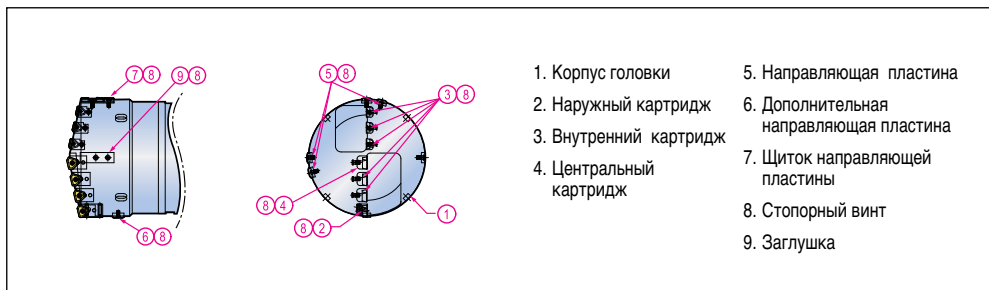

Комплектующие		Диаметр (мм)			
		209.00-214.99	215.00-220.99	221.00-226.99	227.00-232.99
Картридж	Наружный	PERC 402-63	PERC 402-63	PERC 402-63	PERC 402-63
	Регулировочный винт	AS0006-15	AS0006-15	AS0006-15	AS0005-15
	Ключ	H3	H3	H3	H3
	Винт	L1806RH	L1806RH	L1806RH	LS1806RH
	Ключ	H4	H4	H4	H4
	Внутренний	CENC 402-43	CENC 402-43	CENC 402-43	CENC 402-63
	Винт	LS1206	LS1206	LS1206	LS1206
	Ключ	H3L	H3L	H3L	H3L
	Центральный	CENC 402-63	CENC 402-63	CENC 402-63	CENC 402-63
	Винт	LS1206S	LS1206	LS1206	LS1206S
Пластина	Ключ	H3L	H3L	H3L	H3L
	Наружный	TPMX 2807RG	TPMX 2807RG	TPMX 2807RG	TPMX 2807RG
	Винт	CSTB5	CSTB5	CSTB5	CSTB5
	Ключ	T-20D	T-20D	T-20D	T-20D
	Внутренний	TPMX 2405RG	TPMX 2405RG	TPMX 2405RG	TPMX 2807RG
	Винт	CSTB4M	CSTB4M	CSTB4M	CSTB5
	Ключ	T-15D	T-15D	T-15D	T-15D
	Центральный	TPMX 2807RG	TPMX 2807RG	TPMX 2807RG	TPMX 2807RG
Направляющая пластина	Винт	CSTB5	CSTB5	CSTB5	CSTB5
	Ключ	T-20D	T-20D	T-20D	T-20D
	Направляющая пластина	PAD-GC18-SB	PAD-GC18-SB	PAD-GC18-SB	PAD-GC18-SB
	Винт	LS1206S	LS1206S	LS1206S	LS1206S
	Ключ	H3	H3	H3	H3
	Щиток направляющей пластины	PAD-P18	PAD-P18	PAD-P18	PAD-P18
	Винт	LS1206S	LS1206S	LS1206S	LS1206S
	Ключ	H3	H3	H3	H3
	Дополнительная направляющая пластина	PAD-S14	PAD-S14	PAD-S14	PAD-S14
	Винт	CSTA5S	CSTA5S	CSTA5S	CSTA5S
Ключ	T-15D	T-15D	T-15D	T-15D	



TBTA9...SE4



Однотрубная система

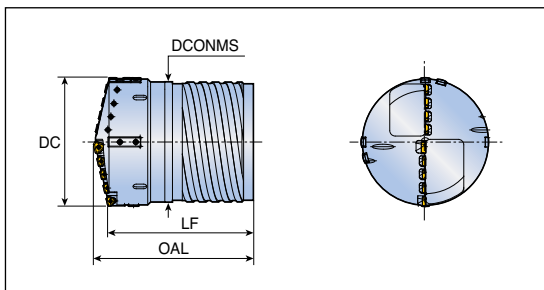

- Наружная четырехзаходная резьба

Обозначение	DC	Размеры (мм)			Труба	
		LF	OAL	DCONMS	Обозначение	Диаметр (мм)
TBTA9 - xxx.xxSE4-226	233.00-243.99	265	294	220	BTSE 226	226
xxx.xxSE4-238	244.00-255.99	265	294	232	BTSE 238	238
xxx.xxSE4-250	256.00-267.99	290	322	244	BTSE 250	250
xxx.xxSE4-262	268.00-279.99	290	323	256	BTSE 262	262
xxx.xxSE4-274	280.00-291.99	290	325	268	BTSE 274	274

TBTA9...SI1



Однотрубная система

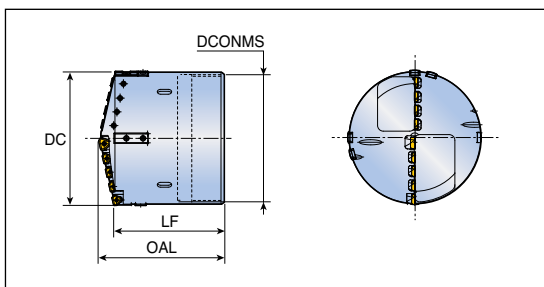

- Внутренняя однозаходная резьба

Обозначение	DC	Размеры (мм)			Труба	
		LF	OAL	DCONMS	Обозначение	Диаметр (мм)
TBTA9 - xxx.xxSI1-214	233.00-233.99	190	217	211	BTSE 214	214
xxx.xxSI1-226	234.00-245.99	190	219	223	BTSE 226	226
xxx.xxSI1-238	246.00-257.99	190	221	235	BTSE 238	238
xxx.xxSI1-250	258.00-269.99	210	242	245	BTSE 250	250
xxx.xxSI1-262	270.00-281.99	210	244	259	BTSE 262	262
xxx.xxSI1-274	282.00-293.99	210	245	271	BTSE 274	274



Комплектующие серии ТВТА9

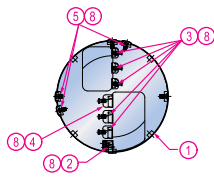
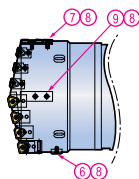

1. Корпус головки
2. Наружный картридж
3. Внутренний картридж
4. Центральный картридж
5. Направляющая пластина
6. Дополнительная направляющая пластина
7. Щиток направляющей пластины
8. Стопорный винт
9. Заглушка

Комплектующие		Диаметр (мм)				
		233.00-247.99	248.00-253.99	254.00-258.99	259.00-264.99	265.00-271.99
Картридж	Наружный	PERC 402-43	PERC 402-63	PERC 402-63	PERC 402-63	PERC 402-63
	Регулировочный винт	AS0005-15	AS0006-15	AS0006-15	AS0006-15	AS0006-15
	Ключ	H2.5	H3	H3	H3	H3
	Винт	LS1806RH	L1806RH	L1806RH	L1806RH	L1806RH
	Ключ	H4	H4	H4	H4	H4
	Внутренний	CENC 402-43	CENC 402-43	CENC 402-43	CENC 402-43	CENC 402-43
	Винт	LS1206	LS1206	LS1206	LS1206	LS1206
	Ключ	H3L	H3L	H3L	H3L	H3L
	Центральный	CENC 402-63	CENC 402-63	CENC 402-63	CENC 402-63	CENC 402-63
	Винт	LS1206S	LS1206S	LS1206S	LS1206S	LS1206S
Пластина	Ключ	H3L	H3L	H3L	H3L	H3L
	Наружный	TPMX 2405 RG	TPMX 2807 RG	TPMX 2807 RG	TPMX 2807 RG	TPMX 2807 RG
	Винт	CSTB4M	CSTB5	CSTB5	CSTB5	CSTB5
	Ключ	T-15D	T-20D	T-20D	T-20D	T-20D
	Внутренний	TPMX 2405 RG	TPMX 2405 RG	TPMX 2405 RG	TPMX 2405 RG	TPMX 2405 RG
	Винт	CSTB4M	CSTB4M	CSTB4M	CSTB4M	CSTB4M
	Ключ	T-15D	T-15D	T-15D	T-15D	T-15D
Направляющая пластина	Центральный	TPMX 2807 RG	TPMX 2807 RG	TPMX 2807 RG	TPMX 2807 RG	TPMX 2807 RG
	Винт	CSTB5	CSTB5	CSTB5	CSTB5	CSTB5
	Ключ	T-20D	T-20D	T-20D	T-20D	T-20D
	Направляющая пластина	PAD-GC18-SB	PAD-GC18-SB	PAD-GC18-SB	PAD-GC18-SB	PAD-GC18-SB
	Винт	LS1206S	LS1206S	LS1206S	LS1206S	LS1206S
	Ключ	H3	H3	H3	H3	H3
	Щиток направляющей пластины	PAD-P18	PAD-P18	PAD-P18	PAD-P18	PAD-P18
	Винт	LS1206S	LS1206S	LS1206S	LS1206S	LS1206S
	Ключ	H3	H3	H3	H3	H3
	Дополнительная направляющая пластина	PAD-S14	PAD-S14	PAD-S14	PAD-S14	PAD-S14
Винт	CSTA5S	CSTA5S	CSTA5S	CSTA5S	CSTA5S	
Ключ	T-15D	T-15D	T-15D	T-15D	T-15D	



Комплектующие серии ТВТА9

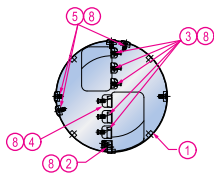
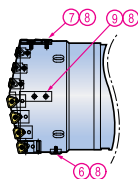

1. Корпус головки
2. Наружный картридж
3. Внутренний картридж
4. Центральный картридж
5. Направляющая пластина
6. Дополнительная направляющая пластина
7. Щиток направляющей пластины
8. Стопорный винт
9. Заглушка

Комплектующие		Диаметр (мм)			
		272.00-275.99	276.00-284.99	285.00-289.99	290.00-293.99
Картридж	Наружный	PERC 402-63	PERC 402-63	PERC 402-63	PERC 402-63
	Регулировочный винт	AS0006-15	AS0006-15	AS0006-15	AS0006-15
	Ключ	H3	H3	H3	H3
	Винт	L1806RH	L1806RH	L1806RH	L1806RH
	Ключ	H4	H4	H4	H4
	Внутренний	CENC 402-63	CENC 402-63	CENC 402-63	CENC 402-63
	Винт	LS1206S	LS1206S	LS1206S	LS1206S
	Ключ	H3L	H3L	H3L	H3L
	Центральный	CENC 402-63	CENC 402-63	CENC 402-63	CENC 402-63
	Винт	LS1206S	LS1206S	LS1206S	LS1206S
Пластина	Наружный	TPMX 2807 RG	TPMX 2807 RG	TPMX 2807 RG	TPMX 2807 RG
	Винт	CSTB5	CSTB5	CSTB5	CSTB5
	Ключ	T-20D	T-20D	T-20D	T-20D
	Внутренний	TPMX 2807 RG	TPMX 2807 RG	TPMX 2807 RG	TPMX 2807 RG
	Винт	CSTB5	CSTB5	CSTB5	CSTB5
	Ключ	T-20D	T-20D	T-20D	T-20D
	Центральный	TPMX 2807 RG	TPMX 2807 RG	TPMX 2807 RG	TPMX 2807 RG
	Винт	CSTB5	CSTB5	CSTB5	CSTB5
Направляющая пластина	Направляющая пластина	PAD-GC18-SB	PAD-GC18-SB	PAD-GC18-SB	PAD-GC18-SB
	Винт	LS1206S	LS1206S	LS1206S	LS1206S
	Ключ	H3	H3	H3	H3
	Щиток направляющей пластины	PAD-P18	PAD-P18	PAD-P18	PAD-P18
	Винт	LS1206S	LS1206S	LS1206S	LS1206S
	Ключ	H3	H3	H3	H3
	Дополнительная направляющая пластина	PAD-S14	PAD-S14	PAD-S14	PAD-S14
	Винт	CSTA5S	CSTA5S	CSTA5S	CSTA5S
	Ключ	T-15D	T-15D	T-15D	T-15D



TBTA-FB...SE4

Однотрубная система

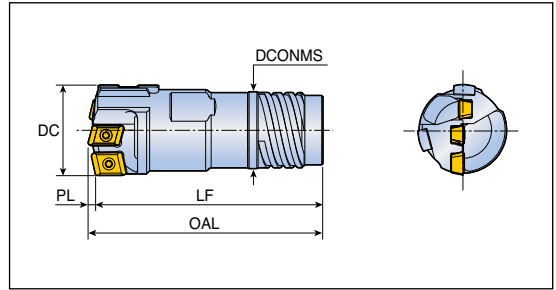

- Наружная четырехзаходная резьба

Обозначение	DC	Размеры (мм)				Труба	
		LF	OAL	DCONMS	PL	Обозначение	Диаметр (мм)
TBTA-FB xx.xxSE4-22	25.00-26.40	70	73	19.5	3	BTSI 022	22
xx.xxSE4-24	26.41-28.70	70	73	21.0	3	BTSI 024	24
xx.xxSE4-26	28.71-31.00	75	78	23.5	3	BTSI 026	26
xx.xxSE4-28	31.01-33.30	75	78	25.5	3	BTSI 028	28
xx.xxSE4-30	33.31-36.20	80	83	28.0	3	BTSI 030	30
xx.xxSE4-33	36.21-39.60	90	93	30.0	3	BTSI 033	33
xx.xxSE4-36	39.61-43.00	95	99	33.0	4	BTSI 036	36
xx.xxSE4-39	43.01-47.00	100	104	36.0	4	BTSI 039	39
xx.xxSE4-43	47.01-51.70	100	104	39.0	4	BTSI 043	43
xx.xxSE4-47	51.71-56.20	110	114	43.0	4	BTSI 047	47
xx.xxSE4-51	56.21-60.60	115	120	47.0	5	BTSI 051	51
xx.xxSE4-51	60.61-65.00	115	120	47.0	5	BTSI 051	51
xx.xxSE4-56A	60.61-65.00	115	120	51.0	5	BTSI 056A	56

Комплектующие: D114, D130, D204
 Труба: D130
 Условия резания: D204

Пластины и направляющие продаются отдельно от корпуса сверла

TBTA-FB...SI1



Однотрубная система

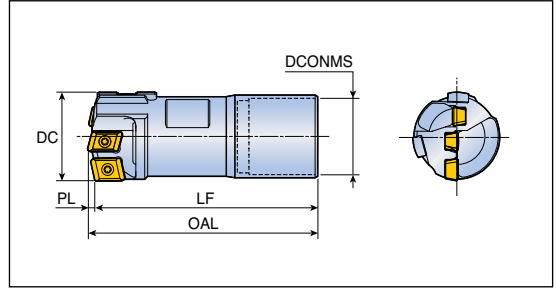

- Внутренняя однозаходная резьба

Обозначение	DC	Размеры (мм)				Труба	
		LF	OAL	DCONMS	PL	Обозначение	Диаметр (мм)
TBTA-FB xx.xxSI1-22	25.00-26.99	70	73	20	3	BTSE 022	22
xx.xxSI1-24	27.00-29.00	70	73	22	3	BTSE 024	24
xx.xxSI1-24	29.01-29.99	70	73	22	3	BTSE 024	24
xx.xxSI1-26	30.00-31.99	75	78	24	3	BTSE 026	26
xx.xxSI1-28	32.00-33.99	75	78	26	3	BTSE 028	28
xx.xxSI1-30	34.00-36.99	90	93	27	3	BTSE 030	30
xx.xxSI1-33	37.00-39.99	95	98	30	3	BTSE 033	33
xx.xxSI1-36	40.00-43.99	100	104	33	4	BTSE 036	36
xx.xxSI1-39	44.00-46.99	105	109	37	4	BTSE 039	39
xx.xxSI1-43	47.00-51.99	105	109	41	4	BTSE 043	43
xx.xxSI1-47	52.00-56.99	110	114	44	4	BTSE 047	47
xx.xxSI1-51	57.00-60.99	115	120	49	5	BTSE 051	51
xx.xxSI1-56	61.00-65.00	115	120	53	5	BTSE 056	56

- Пластины и направляющие продаются отдельно от корпуса сверла



Двухтрубная система

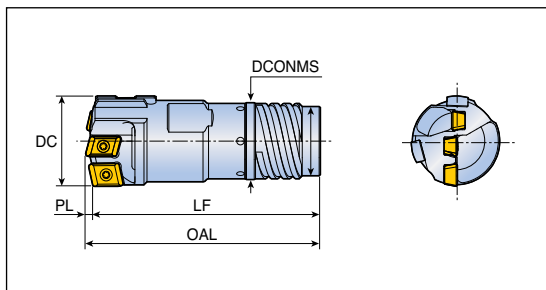

- Наружная четырехзаходная резьба

Обозначение	DC	Размеры (мм)				Труба		
		LF	OAL	DCONMS	PL	Наружная труба	Внутренняя труба	Диаметр (мм)
TBTA-FB xx.xxDE4-23.5	25.00-26.40	70	73	21.0	3	BTDO 023.5	BTDI 016	23.5
xx.xxDE4-26	26.41-28.70	75	78	23.5	3	BTDO 026	BTDI 018	26.0
xx.xxDE4-28	28.71-31.00	75	78	25.5	3	BTDO 028	BTDI 020	28.0
xx.xxDE4-30.5	31.01-33.30	80	83	28.0	3	BTDO 030.5	BTDI 022	30.5
xx.xxDE4-33	33.31-36.20	90	93	30.0	3	BTDO 033	BTDI 024	33.0
xx.xxDE4-35.5	36.21-39.60	95	99	33.0	4	BTDO 035.5	BTDI 026	35.5
xx.xxDE4-39	39.61-43.00	100	104	36.0	4	BTDO 039	BTDI 029	39.0
xx.xxDE4-42.5	43.01-47.00	100	104	39.0	4	BTDO 042.5	BTDI 032	42.5
xx.xxDE4-46.5	47.01-51.70	110	114	43.0	4	BTDO 046.5	BTDI 035	46.5
xx.xxDE4-51	51.71-56.20	115	120	47.5	5	BTDO 051	BTDI 039	51.0
xx.xxDE4-55.5	56.21-65.00	115	120	51.0	5	BTDO 055.5	BTDI 043A	55.5



• Пластины и направляющие продаются отдельно от корпуса сверла

Комплектующие серии ТВТА-FB

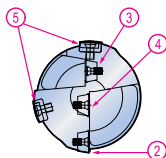
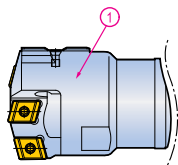

1. Корпус головки
2. Наружная пластина
3. Внутренняя пластина
4. Центральная пластина
5. Направляющая пластина

Комплектующие		Диаметр (мм)			
		25.00-28.00	28.01-29.99	30.00-35.00	35.01-38.00
Пластина	Наружная	NPHT 06003 RG	NPHT 06003 RG	NPHT 07504 RG	NPHT 07504 RG
	Винт	CSTB2.2	CSTB2.2	SR14-560-HG	SR14-560-HG
	Ключ	T-7F	T-7F	T-8F	T-8F
	Внутренняя	NPMT 05503 RG	NPMT 05503 RG	NPMT 06504 RG	NPMT 06504 RG
	Винт	CSTB2.2	CSTB2.2	SR14-560-HG	SR14-560-HG
	Ключ	T-7F	T-7F	T-8F	T-8F
	Центральная	NPMT 05503 LG	NPMT 06504 LG	NPMT 06504 LG	NPMT 08004 LG
	Винт	CSTB2.2	SR14-560-HG	SR14-560-HG	SR14-560-HG
Направляющая пластина	Направляющая	PAD-GO06CD-SA	PAD-GO06CD-SA	PAD-GO07CD-SA	PAD-GO07CD-SA
		PAD-GO06CD-SB	PAD-GO06CD-SB	PAD-GO07CD-SB	PAD-GO07CD-SB
	Винт	SR34-508	SR34-508	CSTB-3L065	CSTB-3L065
	Ключ	T-7F	T-7F	T-9F	T-9F

Комплектующие		Диаметр (мм)			
		38.01-39.00	39.01-41.00	41.01-44.00	44.01-45.00
Пластина	Наружная	NPHT 09004 RG	NPHT 09004 RG	NPHT 09004 RG	NPHT 09004 RG
	Винт	SR14-560-HG	SR14-560-HG	SR14-560-HG	SR14-560-HG
	Ключ	T-8F	T-8F	T-8F	T-8F
	Внутренняя	NPMT 06504 RG	NPMT 06504 RG	NPMT 08004 RG	NPMT 08004 RG
	Винт	SR14-560-HG	SR14-560-HG	SR14-560-HG	SR14-560-HG
	Ключ	T-8F	T-8F	T-8F	T-8F
	Центральная	NPMT 08004 LG	NPMT 08004 LG	NPMT 08004 LG	NPMT 09504 LG
	Винт	SR14-560-HG	SR14-560-HG	SR14-560-HG	SR14-560-HG
Направляющая пластина	Направляющая	PAD-GO07CD-SA	PAD-GO08CD-SA-FB	PAD-GO08CD-SA-FB	PAD-GO08CD-SA-FB
		PAD-GO07CD-SB	PAD-GO08CD-SB-FB	PAD-GO08CD-SB-FB	PAD-GO08CD-SB-FB
	Винт	CSTB-3L065	SR34-506-C	SR34-506-C	SR34-506-C
	Ключ	T-9F	T-9F	T-9F	T-9F

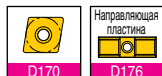

• Пластины и направляющие продаются отдельно от корпуса сверла

Комплектующие серии ТВТА-FB

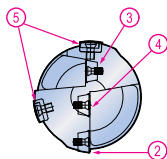
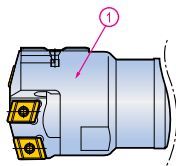

1. Корпус головки
2. Наружная пластина
3. Внутренняя пластина
4. Центральная пластина
5. Направляющая пластина

Комплектующие	Диаметр (мм)				
	45.01-47.00	47.01-51.00	51.01-54.00	54.01-57.00	
Пластина	Наружная	NPHT 09004 RG	NPHT 11004 RG	NPHT 11004 RG	NPHT 11004 RG
	Винт	SR14-560-HG	SR14-560-HG	SR14-560-HG	SR14-560-HG
	Ключ	T-8F	T-8F	T-8F	T-8F
	Внутренняя	NPMT 08004 RG	NPMT 08004 RG	NPMT 09504 RG	NPMT 09504 RG
	Винт	SR14-560-HG	SR14-560-HG	SR14-560-HG	SR14-560-HG
	Ключ	T-8F	T-8F	T-8F	T-8F
	Центральная	NPMT 09504 LG	NPMT 09504 LG	NPMT 09504 LG	NPMT 12504 LG
Направляющая пластина	Направляющая	PAD-GO10CD-SA	PAD-GO10CD-SA	PAD-GO10CD-SA	PAD-GO10CD-SA
		PAD-GO10CD-SB	PAD-GO10CD-SB	PAD-GO10CD-SB	PAD-GO10CD-SB
	Винт	SR14-571/S	SR14-571/S	SR14-571/S	SR14-571/S
	Ключ	T-10/5	T-10/5	T-10/5	T-10/5

Комплектующие	Диаметр (мм)			
	57.01-60.00	60.01-64.00	64.01-65.00	
Пластина	Наружная	NPHT 11004 RG	NPHT 13004 RG	NPHT 13004 RG
	Винт	SR14-560-HG	SR14-560-HG	SR14-560-HG
	Ключ	T-8F	T-8F	T-8F
	Внутренняя	NPMT 09504 RG	NPMT 09504 RG	NPMT 12504 RG
	Винт	SR14-560-HG	SR14-560-HG	SR14-560-HG
	Ключ	T-8F	T-8F	T-8F
	Центральная	NPMT 12504 LG	NPMT 12504 LG	NPMT 12504 LG
Направляющая пластина	Направляющая	PAD-GO12CD-SA	PAD-GO12CD-SA	PAD-GO12CD-SA
		PAD-GO12CD-SB	PAD-GO12CD-SB	PAD-GO12CD-SB
	Винт	SR14-571/S	SR14-571/S	SR14-571/S
	Ключ	T-10/5	T-10/5	T-10/5



D170



D176

- Пластины и направляющие продаются отдельно от корпуса сверла

TBTA-R...SE4



Однотрубная система

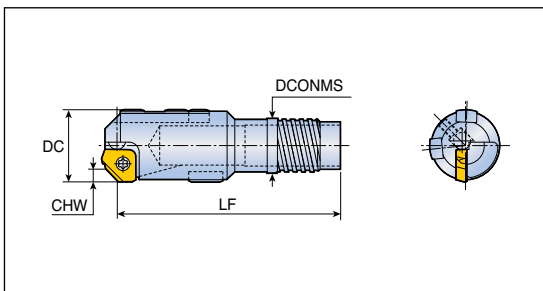

- Наружная четырехзаходная резьба

Обозначение	DC	CHW	Размеры (мм)		Труба	
			LF	DCONMS	Обозначение	Диаметр (мм)
TBTA-R xxx.xxSE4-22	25.00-26.40	2.8	72.5	19.5	BTSI 022	22
xxx.xxSE4-24	26.41-28.70	2.8	72.5	21.0	BTSI 024	24
xxx.xxSE4-26	28.71-31.00	2.8	72.5	23.5	BTSI 026	26
xxx.xxSE4-28	31.01-33.30	2.8	75.5	25.5	BTSI 028	28
xxx.xxSE4-30	33.31-36.20	2.8	75.5	28.0	BTSI 030	30
xxx.xxSE4-33	36.21-39.60	2.8	90.5	30.0	BTSI 033	33
xxx.xxSE4-36	39.61-39.99	2.8	90.5	33.0	BTSI 036	36

Комплектующие

D119 **D130** **D202**

Труба

Уловия резания

TBTA-R...SE4



Однотрубная система



- Наружная четырехзаходная резьба

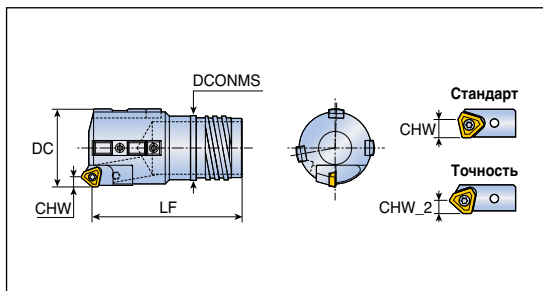

Обозначение	DC	CHW (mm)		Размеры (мм)		Труба	
		Стандарт	Точность	LF	DCONMS	Обозначение	Диаметр (мм)
TBTA-R xxx.xxSE4-36	40.00-43.00	6.4	4	90	33.0	BTSI 036	36
xxx.xxSE4-39	43.01-47.00	6.4	4	95	36.0	BTSI 039	39
xxx.xxSE4-43	47.01-51.70	6.4	4	95	39.0	BTSI 043	43
xxx.xxSE4-47	51.71-56.20	6.4/7.2	4/4.8	100	43.0	BTSI 047	47
xxx.xxSE4-51	56.21-60.60	7.2	4.8	110	47.0	BTSI 051	51
xxx.xxSE4-56A	60.61-65.00	7.2	4.8	110	51.0	BTSI 056A	56
xxx.xxSE4-56B	65.00-66.99	7.2	4.8	150	52.0	BTSI 056B	56
xxx.xxSE4-62	67.00-72.99	10.4	6.4	150	58.0	BTSI 062	62
xxx.xxSE4-68	73.00-79.99	10.4	6.4	150	63.0	BTSI 068	68
xxx.xxSE4-75	80.00-86.99	10.4	6.4	180	70.0	BTSI 075	75
xxx.xxSE4-82	87.00-99.99	10.4	6.4	180	77.0	BTSI 082	82

Комплектующие

Труба

Условия резания

D119 D130 D202

TBTA-R...SI1



Однотрубная система

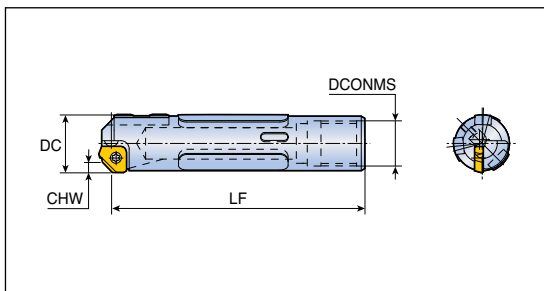

- Внутренняя однозаходная резьба

Обозначение	DC	CHW (мм)	Размеры (мм)		Труба	
			LF	DCONMS	Обозначение	Диаметр (мм)
TBTA-R- xxx.xxSI1-22	25.00-26.99	2.8	110.5	20	BTSE 022	22
xxx.xxSI1-24	27.00-29.99	2.8	110.5	22	BTSE 024	24
xxx.xxSI1-26	30.00-31.99	2.8	110.5	24	BTSE 026	26
xxx.xxSI1-28	32.00-33.99	2.8	110.5	26	BTSE 028	28
xxx.xxSI1-30	34.00-36.99	2.8	135.5	27	BTSE 030	30
xxx.xxSI1-33	37.00-39.99	2.8	135.5	30	BTSE 033	33

TBTA-R...SI1



Однотрубная система

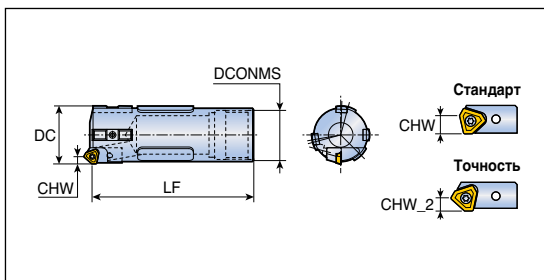

- Внутренняя однозаходная резьба

Обозначение	DC	CHW (мм)		Размеры (мм)		Труба	
		Стандарт	Точность	LF	DCONMS	Обозначение	Диаметр (мм)
TBTA-R- xxx.xxSI1-36	40.00-43.99	6.4	4	135	33	BTSE 036	36
xxx.xxSI1-39	44.00-46.99	6.4	4	135	37	BTSE 039	39
xxx.xxSI1-43	47.00-51.99	6.4	4	145	41	BTSE 043	43
xxx.xxSI1-47	52.00-56.99	7.2	4.8	145	44	BTSE 047	47
xxx.xxSI1-51	57.00-60.99	7.2	4.8	170	49	BTSE 051	51
xxx.xxSI1-56	61.00-67.99	7.2/10.4	4.8/6.4	170	53	BTSE 056	56
xxx.xxSI1-62	68.00-74.99	10.4	6.4	170	59	BTSE 062	62
xxx.xxSI1-68	75.00-80.99	10.4	6.4	205	65	BTSE 068	68
xxx.xxSI1-75	81.00-90.99	10.4	6.4	215	71	BTSE 075	75
xxx.xxSI1-82	91.00-98.99	10.4	6.4	225	79	BTSE 082	82
xxx.xxSI1-94	99.00-110.99	10.4	6.4	235	90	BTSE 094	94

Комплектующие	Труба	Условия резания
D119	D130	D202

Комплектующие серии ТВТА-R

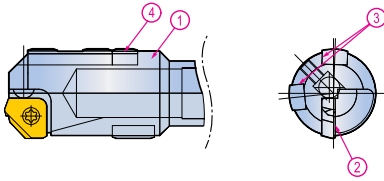

1. Корпус головки
2. Пластина
3. Направляющая пластина
4. Щиток направляющей пластины

Комплектующие		Диаметр (мм)				
		25.00-27.99	28.00-29.99	30.00-37.99	38.00-39.99	
Жёсткий допуск	Картридж	Регулировочный шарик	BALL5	BALL5	BALL5	BALL5
		Регулировочный винт	AS0005-5	AS0005-5	AS0005-5	AS0005-5
		Ключ	H2.5	H2.5	H2.5	H2.5
	Пластина	Винт	-	-	-	-
		Ключ	-	-	-	-
		Пластина	XPMT 16002-45	XPMT 16002-45	XPMT 16002-45	XPMT 16002-45
Нормальный допуск	Картридж	Винт	CSTANO3	CSTANO3	CSTANO3	CSTANO3
		Ключ	T-9D	T-9D	T-9D	T-9D
		Наружная	-	-	-	-
	Пластина	Регулировочный винт	-	-	-	-
		Ключ	-	-	-	-
		Винт	-	-	-	-
Направляющая пластина	Ключ	Ключ	-	-	-	-
		Винт	-	-	-	-
	Пластина	Пластина	XPMT 16002-45	XPMT 16002-45	XPMT 16002-45	XPMT 16002-45
		Винт	CSTANO3	CSTANO3	CSTANO3	CSTANO3
	Ключ	Ключ	T9	T9	T9	T9
		Направляющая пластина (A)	PAD-GO06CD	PAD-GO06CD	PAD-GO07CD	PAD-GO08CD-SA-FB
		Винт	-	-	-	PAD-GO08CD-SB-FB
		Ключ	CSTB3S	CSTB3S	CSTB3S	CSTB3S
		Щиток направляющей пластины (B)	T-9D	T-9D	T-9D	T-9D
		Винт	PAD-P08-120	PAD-P08-120	PAD-P08-140	PAD-P08
		Ключ	CSTB3S	CSTB3S	CSTB3S	CSTB3S
Ключ		T-9D	T-9D	T-9D	T-9D	
Резиновая направляющая пластина (C)		PAD-R10	PAD-R10	PAD-R12	PAD-R15	
Винт	LS0902, 5-6	LS0902, 5-6	LS0903-8	LS0904-10		
Ключ	-	-	H2	H2.5		



D174



D177



D179

- A + B для наружной четырехзаходной резьбы
- A + C для внутренней однозаходной резьбы

Комплектующие серии ТВТА-R

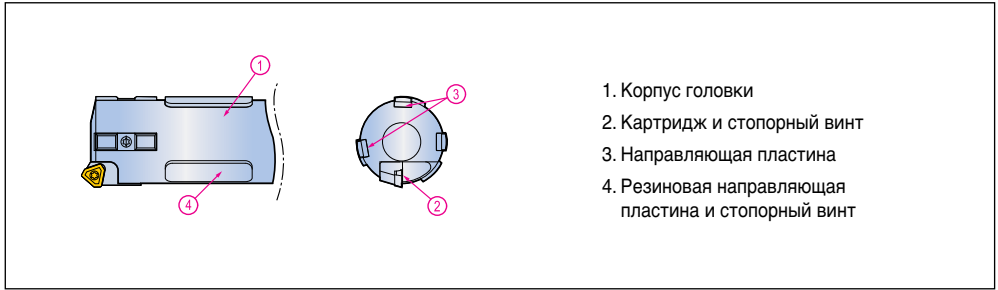

1. Корпус головки
2. Картридж и стопорный винт
3. Направляющая пластина
4. Резиновая направляющая пластина и стопорный винт

Комплектующие		Диаметр (мм)					
		40.00-45.99	46.00-51.99	52.00-56.99	57.00-59.99		
Жёсткий допуск	Картридж	Наружный	PERC-P 04R	PERC-P 04R	PERC-P 32R	PERC-P 32R	
		Регулировочный винт	AS0004-8	AS0004-8	AS0005-10	AS0005-10	
		Ключ	H2	H2	H2.5	H2.5	
	Пластина	Винт	LS1803.5RH	LS1803.5RH	LS1805RH	LS1805RH	
		Ключ	H2.5	H2.5	H3	H3	
		Пластина	TPMX 1403LG	TPMX 1403LG	TPMX 1704LG	TPMX 1704LG	
Нормальный допуск	Картридж	Винт	CSTB2.5	CSTB2.5	CSTB3.5D	CSTB3.5D	
		Ключ	T-8D	T-8D	T-8D	T-8D	
		Наружная	PERC 402-04	PERC 402-04	PERC 402-32	PERC 402-32	
	Пластина	Регулировочный винт	AS0004-8	AS0004-8	AS0005-10	AS0005-10	
		Ключ	H2	H2	H2.5	H2.5	
		Винт	LS1803.5RH	LS1803.5RH	LS1805RH	LS1805RH	
	Направляющая пластина	Картридж	Ключ	H2.5	H2.5	H3	H3
			Пластина	TPMX 1403RG	TPMX 1403RG	TPMX 1704RG	TPMX 1704RG
			Винт	CSTB2.5	CSTB2.5	CSTB3.5D	CSTB3.5D
Пластина		Ключ	T-8D	T-8D	T-8D	T-8D	
		Направляющая пластина (A)	PAD-GO08CD-SA-FB	PAD-GC10-SA	PAD-GC10-SA	PAD-GC14-SB *1	
		Винт	PAD-GO08CD-SB-FB	PAD-GC10-SB	PAD-GC10-SB	-	
Направляющая пластина	Картридж	Ключ	CSTB3S	CSTB4S	CSTB4S	CSTB4S	
		Винт	T-9D	T-15D	T-15D	T-15D	
	Пластина	Щиток направляющей пластины (B)	PAD-P08	PAD-P10	PAD-P10	PAD-P14	
		Винт	CSTB3S	CSTB4S	CSTB4S	CSTB4S	
	Картридж	Ключ	T-9D	T-15D	T-15D	T-15D	
		Резиновая направляющая пластина (C)	PAD-R15	PAD-R15	PAD-R15	PAD-R20	
	Пластина	Винт	LS0904-10	LS0904-10	LS0904-10	LS0905-12	
		Ключ	H2.5	H2.5	H2.5	H3	



- A + B для наружной четырехзаходной резьбы
- A + C для внутренней однозаходной резьбы
- *11 Внутренняя резьба = PAD-GC10-SA/SB
- *21 CSTB4S

Комплектующие серии TBTA-R

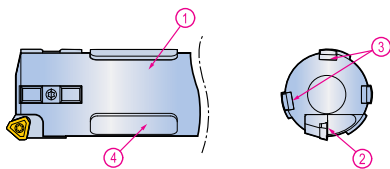

1. Корпус головки
2. Картридж и стопорный винт
3. Направляющая пластина
4. Резиновая направляющая пластина и стопорный винт

Комплектующие		Диаметр (мм)				
		60.00-80.99	81.00-90.99	91.00-99.99	100.00-122.99	
Жёсткий допуск	Картридж	Наружный	PERC-P 43R	PERC-P 43R	PERC-P 43R	PERC-P 43R
		Регулировочный винт	AS0005-15	AS0005-15	AS0005-15	AS0005-15
		Ключ	H2.5	H2.5	H2.5	H2.5
	Пластина	Винт	LS1806RH	LS1806RH	LS1806RH	LS1806RH
		Ключ	H4	H4	H4	H4
		Пластина	TPMX 2405LG	TPMX 2405LG	TPMX 2405LG	TPMX 2405LG
Нормальный допуск	Картридж	Наружная	PERC 402-43	PERC 402-43	PERC 402-43	PERC 402-43
		Регулировочный винт	AS0005-15	AS0005-15	AS0005-15	AS0005-15
		Ключ	H2.5	H2.5	H2.5	H2.5
	Пластина	Винт	LS1806RH	LS1806RH	LS1806RH	LS1806RH
		Ключ	H4	H4	H4	H4
		Пластина	TPMX 2405RG	TPMX 2405RG	TPMX 2405RG	TPMX 2405RG
Направляющая пластина	Винт	CSTB4M	CSTB4M	CSTB4M	CSTB4M	
	Ключ	T-15D	T-15D	T-15D	T-15D	
	Направляющая пластина (A)	PAD-GC14-SB	PAD-GC14-SB	PAD-GC14-SB	PAD-GC18-SB	
	Винт	CSTA5S	CSTA5S	CSTA5S	LS1206S	
	Ключ	T-15D	T-15D	T-15D	H3	
	Щиток направляющей пластины (B)	PAD-P14	PAD-P14	PAD-P14	PAD-P18	
	Винт	CSTA5S	CSTA5S	CSTA5S	LS1206S	
	Ключ	T-15D	T-15D	T-15D	H3	
	Резиновая направляющая пластина (C)	PAD-R20	PAD-R30	PAD-R35	PAD-R35	
	Винт	LS0905-12	LS0906-15	LS0906-15	LS0906-15	
	Ключ	H3	H4	H4	H4	



D174



D177



D179

- A + B для наружной четырехзаходной резьбы
- A + C для внутренней однозаходной резьбы

Однотрубная система

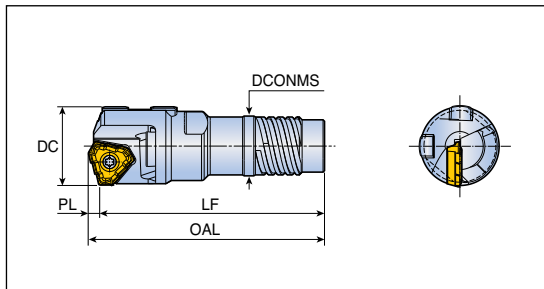

- Наружная четырехзаходная резьба

Обозначение	DC	Размеры (мм)				Труба	
		LF	OAL	DCONMS	PL	Обозначение	Диаметр (мм)
TBTA- TRxx.xxSE4-14	16.00-16.70	55.0	57.2	12.6	2.2	BTSI 014	14
TRxx.xxSE4-15	16.71-17.70	55.0	57.2	13.6	2.2	BTSI 015	15
TRxx.xxSE4-16	17.71-18.90	56.0	59.0	14.5	3.0	BTSI 016	16
TRxx.xxSE4-17	18.91-20.00	56.0	59.0	15.5	3.0	BTSI 017	17
TRxx.xxSE4-18	20.01-21.80	60.0	63.2	16.0	3.2	BTSI 018	18
TRxx.xxSE4-20	21.81-21.99	63.5	66.7	18.0	3.2	BTSI 020	20
TRxx.xxSE4-20	22.00-24.10	65.5	68.9	18.0	3.4	BTSI 020	20
TRxx.xxSE4-22	24.11-26.40	65.5	69.1	19.5	3.6	BTSI 022	22
TRxx.xxSE4-24	26.41-28.00	65.6	69.1	21.0	3.6	BTSI 024	24

Комплектуемые Труба Уловия резания

D125 D130 D208

- Пластины и направляющие продаются отдельно от корпуса сверла.

Однотрубная система

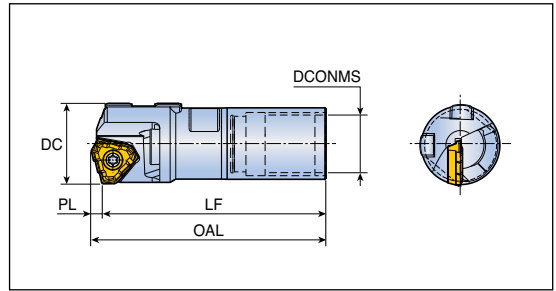

- Внутренняя однозаходная резьба

Обозначение	DC	Размеры (мм)				Труба	
		LF	OAL	DCONMS	PL	Обозначение	Диаметр (мм)
TBTA- TR16.00S11 -13A	16.00	53.5	55.7	10.8	2.2	BTSE 013A	13
TRxx.xxS11 -13B	16.01-16.50	53.5	55.7	11.1	2.2	BTSE 013B	13
TRxx.xxS11 -14A	16.51-17.25	53.5	55.7	11.8	2.2	BTSE 014A	14
TRxx.xxS11 -14B	17.26-18.00	53.5	55.7	12.1	2.2	BTSE 014B	14
TRxx.xxS11 -15	18.01-19.00	53.5	56.5	12.8	3.0	BTSE 015	15
TRxx.xxS11 -16.5	19.01-19.99	53.5	56.7	13.8	3.2	BTSE 016.5	16.5
TRxx.xxS11 -18	20.00-21.99	58.0	61.2	14.5	3.2	BTSE 018	18
TRxx.xxS11 -20	22.00-24.99	60.0	63.4	16.0	3.4	BTSE 020	20
TR25.00S11 -22	25.00	60.0	63.4	17.0	3.4	BTSE 022	22
TRxx.xxS11 -22	25.01-26.99	65.0	68.6	17.0	3.6	BTSE 022	22
TRxx.xxS11 -24	27.00-28.00	65.0	68.6	19.0	3.6	BTSE 024	24

Комплектующие

D125

Труба

D130

Условия
резания

D208

• Пластины и направляющие продаются отдельно от корпуса сверла.

Двухтрубная система

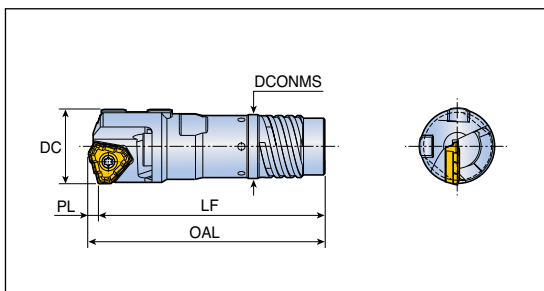

- Наружная четырехзаходная резьба

Обозначение	DC	Размеры (мм)				Труба	
		LF	OAL	DCONMS	PL	Обозначение	Диаметр (мм)
TBTA- TRxx.xxDE4-18	18.40-20.00	59.0	62.0	16.0	3.0	BTDO 018	18
TRxx.xxDE4-19.5	20.01-21.80	63.5	66.7	18.0	3.2	BTDO 019.5	19.5
TRxx.xxDE4-21.5	21.81-21.99	63.5	66.7	19.5	3.2	BTDO 021.5	21.5
TRxx.xxDE4-21.5	22.00-24.10	65.5	68.9	19.5	3.4	BTDO 021.5	21.5
TRxx.xxDE4-23.5	24.11-25.00	65.5	68.9	21.0	3.4	BTDO 023.5	23.5
TRxx.xxDE4-23.5	25.01-26.40	65.5	71.1	21.0	3.6	BTDO 023.5	23.5
TRxx.xxDE4-26	26.41-28.00	70.5	74.1	23.5	3.6	BTDO 026	26

- Пластины и направляющие продаются отдельно от корпуса сверла.

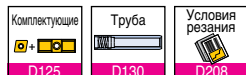

Комплектующие серии ТВТА-TR

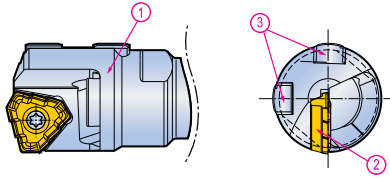

1. Корпус головки
2. Пластина
3. Направляющая пластина

Комплектующие		Диаметр (мм)		
		16.00-18.00	18.01-20.00	20.01-21.00
Пластина	Пластина	TOGT 080305 RS TT9030	TOGT 090305 RS TT9030	TOGT 100305 RS TT9030
	Винт	SR14-560/S	CSTB2.5S*	CSTB3S*
	Ключ	T-8F	T-8F	T-9F
Направляющая пластина	Направляющая пластина	PAD-GO05-075CD-SA	PAD-GO06-085CD-SA	PAD-GO06-085CD-SA
		PAD-GO05-075CD-SB	PAD-GO06-085CD-SB	PAD-GO06-085CD-SB
	Винт	SR34-508	CSTB2.5S*	CSTB2.5S*
	Ключ	T-7F	T-7F	T-7F

Комплектующие		Диаметр (мм)		
		21.01-21.99	22.00-25.00	25.01-28.00
Пластина	Пластина	TOGT 100305 RS TT9030	TOGT 110405 RS TT9030	TOGT 120405 RS TT9030
	Винт	CSTB3S*	CSTB3.5H*	CSTB4S*
	Ключ	T-9F	T-15F	T-15F
Направляющая пластина	Направляющая пластина	PAD-GO06-100CD-SA	PAD-GO06-100CD-SA	PAD-GO06CD-SA
		PAD-GO06-100CD-SB	PAD-GO06-100CD-SB	PAD-GO06CD-SB
	Винт	CSTB2.2S*	CSTB2.2S*	CSTB2.2S*
	Ключ	T-7F	T-7F	T-7F



• Пластины и направляющие продаются отдельно от корпуса сверла

Однотрубная система

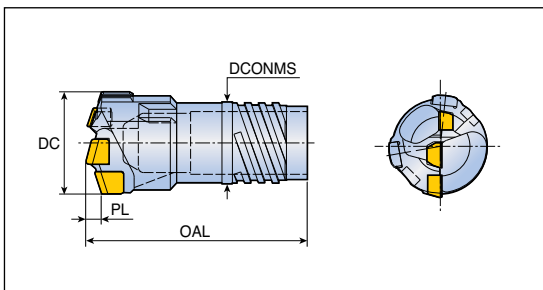

- Наружная четырехзаходная резьба

Обозначение	DC	Размеры (мм)			Труба	
		OAL	PL	DCONMS	Обозначение	Диаметр (мм)
BTA xxx.xx SE2-11*	12.60-13.10	43.0	1.1	9.6	BTSI011	11
xxx.xx SE2-11*	13.11-13.60	43.0	1.1	9.6	BTSI011	11
xxx.xx SE2-12*	13.61-14.10	43.0	1.2	10.6	BTSI012	12
xxx.xx SE2-12*	14.11-14.60	43.0	1.2	10.6	BTSI012	12
xxx.xx SE2-13*	14.61-15.10	43.0	1.3	11.6	BTSI013	13
xxx.xx SE2-13*	15.11-15.59	43.0	1.3	11.6	BTSI013	13
xxx.xx SE4-14	15.60-16.20	43.0	2.7	12.6	BTSI014	14
xxx.xx SE4-14	16.21-16.70	43.0	2.7	12.6	BTSI014	14
xxx.xx SE4-15	16.71-17.20	43.0	2.7	13.6	BTSI015	15
xxx.xx SE4-15	17.21-17.70	43.0	2.7	13.6	BTSI015	15
xxx.xx SE4-16	17.71-18.40	47.0	2.8	14.5	BTSI016	16
xxx.xx SE4-16	18.41-18.90	47.0	2.9	14.5	BTSI016	16
xxx.xx SE4-17	18.91-19.20	47.0	2.9	15.5	BTSI017	17
xxx.xx SE4-17	19.21-20.00	47.0	2.9	15.5	BTSI017	17
xxx.xx SE4-18	20.01-20.90	52.5	3.2	16.0	BTSI018	18
xxx.xx SE4-18	20.91-21.80	52.5	3.2	16.0	BTSI018	18
xxx.xx SE4-20	21.81-22.90	56.0	3.2	18.0	BTSI020	20
xxx.xx SE4-20	22.91-24.10	56.0	3.2	18.0	BTSI020	20
xxx.xx SE4-22	24.11-25.20	57.5	3.5	19.5	BTSI022	22
xxx.xx SE4-22	25.21-26.40	57.5	3.5	19.5	BTSI022	22
xxx.xx SE4-24	26.41-27.50	57.5	3.7	21.0	BTSI024	24
xxx.xx SE4-24	27.51-28.70	57.5	3.7	21.0	BTSI024	24
xxx.xx SE4-26	28.71-29.80	63.5	4.0	23.5	BTSI026	26
xxx.xx SE4-26	29.81-31.00	63.5	4.0	23.5	BTSI026	26
xxx.xx SE4-28	31.01-32.10	63.5	4.3	25.5	BTSI028	28
xxx.xx SE4-28	32.11-33.30	63.5	4.3	25.5	BTSI028	28
xxx.xx SE4-30	33.31-34.80	63.5	4.5	28.0	BTSI030	30
xxx.xx SE4-30	34.81-36.20	63.5	4.5	28.0	BTSI030	30
xxx.xx SE4-33	36.21-37.30	73.5	4.8	30.0	BTSI033	33
xxx.xx SE4-33	37.31-38.40	73.5	4.8	30.0	BTSI033	33
xxx.xx SE4-33	38.41-39.60	73.5	4.8	30.0	BTSI033	33
xxx.xx SE4-36	39.61-40.60	73.5	5.6	33.0	BTSI036	36
xxx.xx SE4-36	40.61-41.80	73.5	5.6	33.0	BTSI036	36
xxx.xx SE4-36	41.81-43.00	73.5	5.6	33.0	BTSI036	36
xxx.xx SE4-39	43.01-44.30	75.0	5.4	36.0	BTSI039	39



- *1* головка с 2 режущими кромками, двухзаходная резьба

Однотрубная система

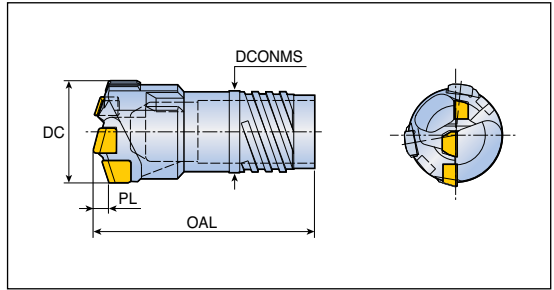

- Наружная четырехзачодная резьба

Обозначение	DC	Размеры (мм)			Труба	
		OAL	PL	DCONMS	Обозначение	Диаметр (мм)
BTA xxx.xx SE4-39	44.31-45.60	75.0	5.4	36.0	BTSI039	39
xxx.xx SE4-39	45.61-47.00	75.0	5.4	36.0	BTSI039	39
xxx.xx SE4-43	47.01-48.50	75.0	6.1	39.0	BTSI043	43
xxx.xx SE4-43	48.51-50.10	75.0	6.1	39.0	BTSI043	43
xxx.xx SE4-43	50.11-51.70	75.0	6.1	39.0	BTSI043	43
xxx.xx SE4-47	51.71-53.20	82.0	6.5	43.0	BTSI047	47
xxx.xx SE4-47	53.21-54.70	82.0	6.5	43.0	BTSI047	47
xxx.xx SE4-47	54.71-56.20	82.0	6.5	43.0	BTSI047	47
xxx.xx SE4-51	56.21-58.40	84.0	6.6	47.0	BTSI051	51
xxx.xx SE4-51	58.41-60.60	84.0	6.6	47.0	BTSI051	51
xxx.xx SE4-51	60.61-62.80	84.0	7.0	47.0	BTSI051	51
xxx.xx SE4-51	62.81-65.00	84.0	7.0	47.0	BTSI051	51
xxx.xx SE4-56	60.61-62.80	84.0	7.0	51.0	BTSI056	56
xxx.xx SE4-56	62.81-65.00	84.0	7.0	51.0	BTSI056	56

Труба D130	Условия резания D206
-------------------	-----------------------------

Двухтрубная система

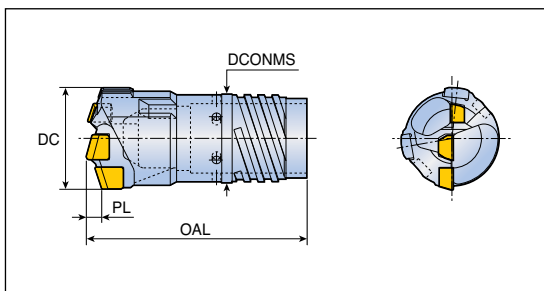

- Наружная четырехзаходная резьба

Обозначение	DC	Размеры (мм)			Труба		
		OAL	PL	DCONMS	Наружная труба	Внутренняя труба	Диаметр (мм)
ВТА xxx.xx DE4-18	18.41-19.20	50.0	2.9	16.0	BTDO018	BTDI012	18.0
xxx.xx DE4-18	19.21-20.00	50.0	2.9	16.0	BTDO018	BTDI012	18.0
xxx.xx DE4-19.5	20.01-20.90	56.0	3.2	18.0	BTDO019.5	BTDI014	19.5
xxx.xx DE4-19.5	20.91-21.80	56.0	3.2	18.0	BTDO019.5	BTDI014	19.5
xxx.xx DE4-21.5	21.81-22.90	56.0	3.2	19.5	BTDO021.5	BTDI015	21.5
xxx.xx DE4-21.5	22.91-24.10	56.0	3.2	19.5	BTDO021.5	BTDI015	21.5
xxx.xx DE4-23.5	24.11-25.20	57.5	3.5	21.0	BTDO023.5	BTDI016	23.5
xxx.xx DE4-23.5	25.21-26.40	57.5	3.5	21.0	BTDO023.5	BTDI016	23.5
xxx.xx DE4-26	26.41-27.50	60.5	3.7	23.5	BTDO026	BTDI018	26.0
xxx.xx DE4-26	27.51-28.70	60.5	3.7	23.5	BTDO026	BTDI018	26.0
xxx.xx DE4-28	28.71-29.80	63.5	4.0	25.5	BTDO028	BTDI020	28.0
xxx.xx DE4-28	29.81-31.00	63.5	4.0	25.5	BTDO028	BTDI020	28.0
xxx.xx DE4-30.5	31.01-32.10	63.5	4.1	28.0	BTDO030.5	BTDI022	30.5
xxx.xx DE4-30.5	32.11-33.30	63.5	4.1	28.0	BTDO030.5	BTDI022	30.5
xxx.xx DE4-33	33.31-34.80	70.5	4.5	30.0	BTDO033.0	BTDI024	33.0
xxx.xx DE4-33	34.81-36.20	70.5	4.5	30.0	BTDO033.0	BTDI024	33.0
xxx.xx DE4-35.5	36.21-37.30	73.5	4.8	33.0	BTDO035.5	BTDI026	35.5
xxx.xx DE4-35.5	37.31-38.40	73.5	4.8	33.0	BTDO035.5	BTDI026	35.5
xxx.xx DE4-35.5	38.41-39.60	73.5	4.8	33.0	BTDO035.5	BTDI026	35.5
xxx.xx DE4-39	39.61-40.60	73.5	5.3	36.0	BTDO039	BTDI029	39.0
xxx.xx DE4-39	40.61-41.80	73.5	5.3	36.0	BTDO039	BTDI029	39.0
xxx.xx DE4-39	41.81-43.00	73.5	5.3	36.0	BTDO039	BTDI029	39.0
xxx.xx DE4-42.5	43.01-44.30	75.0	5.5	39.0	BTDO042.5	BTDI032	42.5
xxx.xx DE4-42.5	44.31-45.60	75.0	5.5	39.0	BTDO042.5	BTDI032	42.5
xxx.xx DE4-42.5	45.61-47.00	75.0	5.5	39.0	BTDO042.5	BTDI032	42.5
xxx.xx DE4-46.5	47.01-48.50	79.0	6.1	43.0	BTDO046.5	BTDI035	46.5
xxx.xx DE4-46.5	48.51-50.10	79.0	6.1	43.0	BTDO046.5	BTDI035	46.5
xxx.xx DE4-46.5	50.11-51.70	79.0	6.1	43.0	BTDO046.5	BTDI035	46.5
xxx.xx DE4-51	51.71-53.20	82.0	6.5	47.0	BTDO051	BTDI039	51.0
xxx.xx DE4-51	53.21-54.70	82.0	6.5	47.0	BTDO051	BTDI039	51.0
xxx.xx DE4-51	54.71-56.20	82.0	6.5	47.0	BTDO051	BTDI039	51.0
xxx.xx DE4-55.5	56.21-58.40	84.0	6.6	51.0	BTDO055.5	BTDI043A	55.5
xxx.xx DE4-55.5	58.41-60.60	84.0	6.6	51.0	BTDO055.5	BTDI043A	55.5
xxx.xx DE4-55.5	60.61-62.80	84.0	6.6	51.0	BTDO055.5	BTDI043A	55.5
xxx.xx DE4-55.5	62.81-65.00	84.0	6.6	51.0	BTDO055.5	BTDI043A	55.5

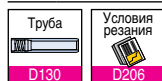

Однотрубная система

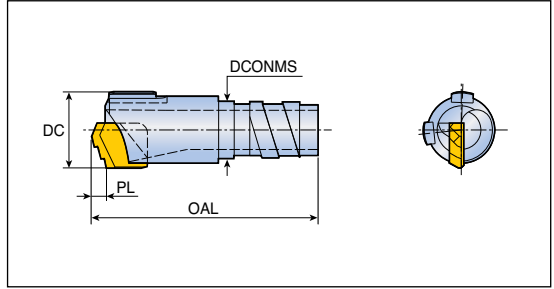

- Наружная однозаходная резьба

Обозначение	DC	Размеры (мм)			Труба	
		OAL	PL	DCONMS	Обозначение	Диаметр (мм)
BTS xxx.xx SE1-7.1	8.00-8.99	34	2.0	6.0	BTSO071	7.1
xxx.xx SE1-8.3	9.00-9.99	34	2.0	7.2	BTSO083	8.3
xxx.xx SE1-9	10.00-10.99	34	2.2	7.6	BTSO090	9.0
xxx.xx SE1-10	11.00-11.99	34	2.2	8.6	BTSO100	10.0
xxx.xx SE1-11	12.00-13.49	34	2.3	9.1	BTSO110	11.0
xxx.xx SE1-12	13.50-14.79	34	2.4	10.8	BTSO120	12.0

BTS...SE2/SE4

Однотрубная система

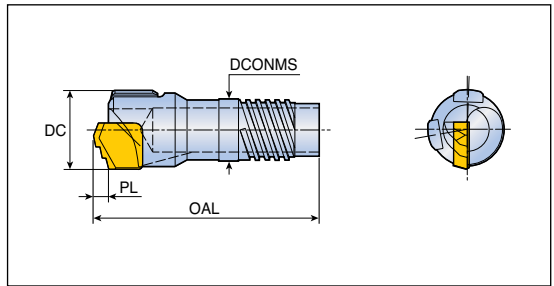

- Наружная однозаходная резьба

Обозначение	DC	Размеры (мм)			Труба	
		OAL	PL	DCONMS	Обозначение	Диаметр (мм)
BTS xxx.xx SE2-11*	12.60-13.60	40	2.3	9.6	BTSI011	11
xxx.xx SE2-12*	13.61-14.60	40	2.4	10.6	BTSI012	12
xxx.xx SE2-13*	14.61-15.59	40	3.0	11.6	BTSI013	13
xxx.xx SE4-14	15.60-16.70	40	2.4	12.6	BTSI014	14
xxx.xx SE4-15	16.71-17.70	40	3.0	13.6	BTSI015	15
xxx.xx SE4-16	17.71-18.90	40	3.3	14.5	BTSI016	16
xxx.xx SE4-17	18.91-20.00	40	3.3	15.5	BTSI017	17



- '*1' Обозначает наружную двухзаходную резьбу

Однотрубное крепление

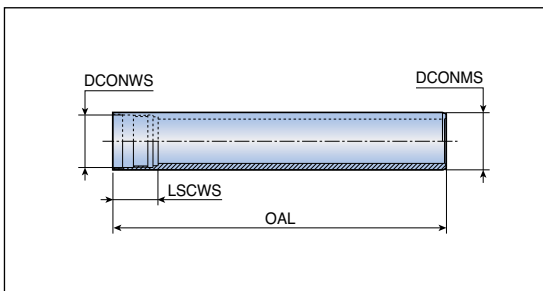

- Внутренняя четырехзаходная резьба

Обозначение	DC	Размеры (мм)		
		DCONMS	DCONWS	LSCWS
BTSI 011 *	12.60-13.60	11.0	9.6	22
012 *	13.61-14.60	12.0	10.6	22
013 *	14.61-15.59	13.0	11.6	22
014	15.60-16.70	14.0	12.6	21
015	16.71-17.70	15.0	13.6	21
016	17.71-18.90	16.0	14.5	22
017	18.91-20.00	17.0	15.5	22
018	20.01-21.80	18.0	16.0	27.5
020	21.81-24.10	20.0	18.0	30
022	24.11-26.40	22.0	19.5	30
024	26.41-28.70	24.0	21.0	30
026	28.71-31.00	26.0	23.5	33
028	31.01-33.30	28.0	25.5	33
030	33.31-36.20	30.0	28.0	33
033	36.21-39.60	33.0	30.0	40
036	39.61-43.00	36.0	33.0	40
039	43.01-47.00	39.0	36.0	40
043	47.01-51.70	43.0	39.0	40
047	51.71-56.20	47.0	43.0	44

- Пожалуйста, указывайте при заказе общую длину (OAL)
- '*1' Отмеченные позиции для внутренней двухзаходной резьбы

Однотрубное крепление

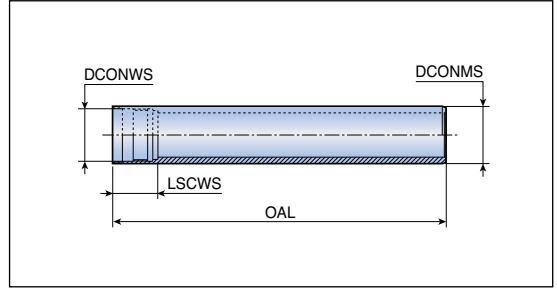

- Внутренняя четырехзаходная резьба

Обозначение	DC	Размеры (мм)		
		DCONMS	DCONWS	LSCWS
BTSI 051	56.21-60.60	51.0	47.0	44
056A	60.61-65.00	56.0	51.0	44
056B	65.00-66.99	56.0	52.0	75
062	67.00-72.99	62.0	58.0	75
068	73.00-79.99	68.0	63.0	75
075	80.00-86.99	75.0	70.0	97
082	87.00-99.99	82.0	77.0	97
094	100.00-111.99	94.0	89.0	97
106	112.00-123.99	106.0	101.0	118
118	124.00-135.99	118.0	113.0	118
130	136.00-147.99	130.0	125.0	118
142	148.00-159.99	142.0	137.0	139
154	160.00-171.99	154.0	149.0	139
166	172.00-183.99	166.0	161.0	139
178	184.00-195.99	178.0	173.0	144
190	196.00-207.99	190.0	185.0	144
202	208.00-219.99	202.0	197.0	144
214	220.00-231.99	214.0	208.0	164
226	232.00-243.99	226.0	220.0	164
238	244.00-255.99	238.0	232.0	164
250	256.00-267.99	250.0	244.0	184
262	268.00-279.99	262.0	256.0	184
274	280.00-291.99	274.0	268.0	184

- Пожалуйста, указывайте при заказе общую длину (OAL)

Однотрубное крепление

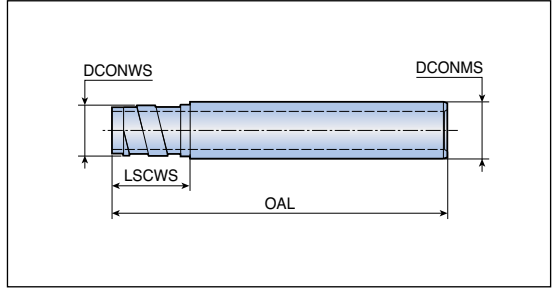

- Наружная однозаходная резьба

Обозначение	DC	Размеры (мм)		
		DCONMS	DCONWS	LSCWS
BTSE 012A	14.50-15.00	12.0	11.5	23
012B	15.01-15.50	12.0	11.8	23
013A	15.51-16.00	13.0	12.4	23
013B	16.01-16.50	13.0	12.7	23
014A	16.51-17.25	14.0	13.4	23
014B	17.26-18.00	14.0	13.7	23
015	18.01-19.00	15.0	14.4	23
016.5	19.01-19.99	16.5	15.4	23
018	20.00-21.99	18.0	16.5	26
020	22.00-24.99	20.0	19.0	26
022	25.00-26.99	22.0	20.0	26
024	27.00-29.99	24.0	22.0	26
026	30.00-31.99	26.0	24.0	26
028	32.00-33.99	28.0	26.0	26
030	34.00-36.99	30.0	27.0	41
033	37.00-39.99	33.0	30.0	41
036	40.00-43.99	36.0	33.0	41
039	44.00-46.99	39.0	37.0	41
043	47.00-51.99	43.0	41.0	41

- Пожалуйста, указывайте при заказе общую длину (OAL)

Однотрубное крепление

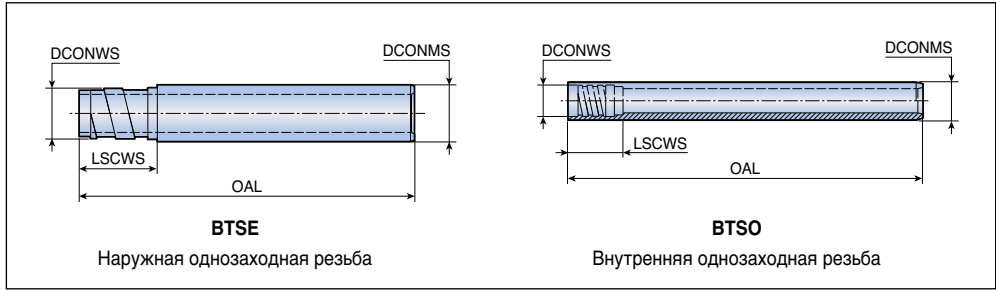

Обозначение	DC	Размеры (мм)			
		DCONMS	DCONWS	LSCWS	
BTSE 047	52.00-56.99	47.0	44	-	41
051	57.00-60.99	51.0	49	-	41
056	61.00-67.99	56.0	53	-	41
062	68.00-74.99	62.0	59	-	41
068	75.00-80.99	68.0	65	-	71
075	81.00-90.99	75.0	71	-	71
082	91.00-98.99	82.0	79	-	71
094	99.00-110.99	94.0	90	-	71
106	111.00-122.99	106.0	102	-	71
118	123.00-134.99	118.0	114	-	71
130	135.00-148.99	130.0	126	-	71
142	149.00-161.99	142.0	139	-	71
154	162.00-173.99	154.0	151	-	86
166	174.00-185.99	166.0	163	-	86
178	186.00-197.99	178.0	175	-	86
190	198.00-209.99	190.0	187	-	86
202	210.00-221.99	202.0	199	-	86
214	222.00-233.99	214.0	211	-	86
226	234.00-245.99	226.0	223	-	86
238	246.00-257.99	238.0	235	-	86
250	258.00-269.99	250.0	247	-	121
262	270.00-281.99	262.0	259	-	121
274	282.00-293.99	274.0	271	-	121
BTSO 071	8.00-8.99	7.1	-	6.0	13.5
083	9.00-9.99	8.3	-	7.2	13.5
090	10.00-10.99	9.0	-	7.6	13.5
100	11.00-11.99	10.0	-	8.6	13.5
110	12.00-13.49	11.0	-	9.1	13.5
120	13.50-14.79	12.0	-	10.8	13.5

• Пожалуйста, указывайте при заказе общую длину (OAL)

Двухтрубное соединение

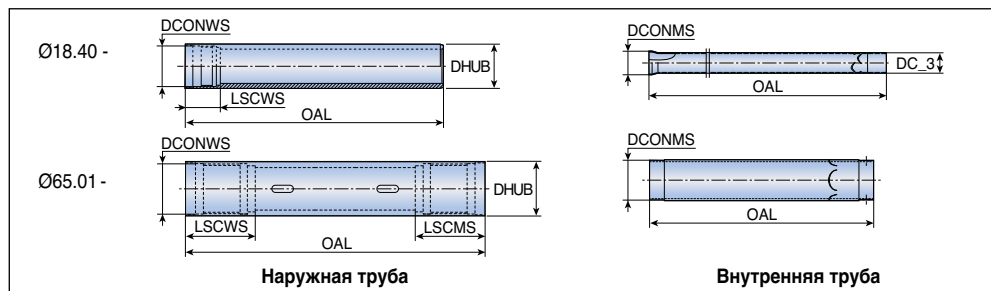

DC	Наружная труба	Размеры (мм)			Внутренняя труба	Размеры (мм)	
		DHUB	DCONWS	LSCWS		DCONMS	DC_3
18.40-20.00	BTDO 018	18.0	16	27.5	BTDI 012	12	10
20.01-21.80	019.5	19.5	18	30	014	14	12
21.81-24.10	021.5	21.5	19.5	30	015	15	13
24.11-26.40	023.5	23.5	21	30	016	16	14
26.41-28.70	026	26.0	23.5	33	018	18	16
28.71-31.00	028	28.0	25.5	33	020	20	18
31.01-33.30	030.5	30.5	28	33	022	22	20
33.31-36.20	033	33.0	30	40	024	24	22
36.21-39.60	035.5	35.5	33	40	026	26	24
39.61-43.00	039	39.0	36	40	029	29	27
43.01-47.00	042.5	42.5	39	40	032	32	30
47.01-51.70	046.5	46.5	43	44	035	35	32
51.71-56.20	051	51.0	47	44	039	39	36
56.21-65.00	055.5	55.5	51	44	043A	43	40
65.01-69.99	056	56.0	52	75	043B	40	-
70.00-72.99	062	62.0	58	75	048	44	-
73.00-79.99	068	68.0	63	75	053	48	-
80.00-86.99	075	75.0	70	97	059	54	-
87.00-99.99	082	82.0	77	97	066	60	-
100.00-111.99	094	94.0	89	97	078	70	-
112.00-123.99	106	106.0	101	118	090	80	-
124.00-135.99	118	118.0	113	118	092	80	-
136.00-147.99	130	130.0	125	118	104	95	-
148.00-159.99	142	142.0	137	139	116	100	-
160.00-171.99	154	154.0	149	139	128	120	-
172.00-183.99	166	166.0	161	139	138	130	-

- Пожалуйста, укажите при заказе общую длину (OAL)
- Для диаметров 18.40-65.00 (**BTDO 055.5**) необходимо заказывать внутреннюю трубу на 30 мм длиннее наружной.
- Для диаметров 65.00-123.99 (**BTDO 056 - BTDO 106**) необходимо заказывать внутреннюю трубу на 190 мм длиннее наружной.
- Для диаметров 124.00-183.99 (**BTDO 118 - BTDO 166**) необходимо заказывать внутреннюю трубу на 220 мм длиннее наружной.

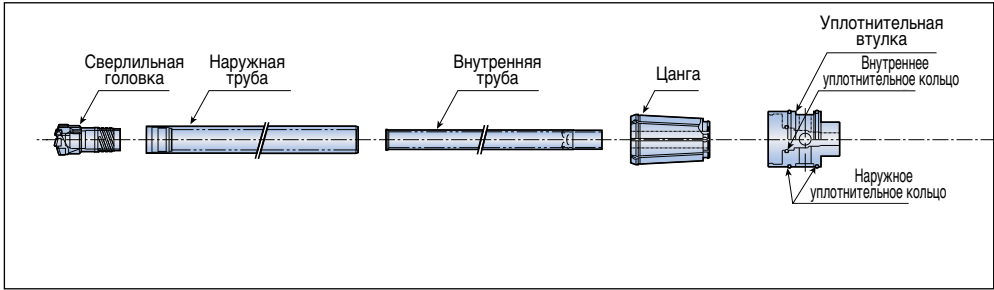

Обозначение		DC	Цанга
BTDO 018	BTDI 012	18.40-19.20	COLLET 4-18
018	012	19.21-20.00	COLLET 4-18
019.5	014	20.01-20.90	COLLET 4-19.5
019.5	014	20.91-21.80	COLLET 4-19.5
021.5	015	21.81-22.90	COLLET 4-21.5
021.5	015	22.91-24.10	COLLET 4-21.5
023.5	016	24.11-25.20	COLLET 4-23.5
023.5	016	25.21-26.40	COLLET 4-23.5
026	018	26.41-27.50	COLLET 4-26
026	018	27.51-28.70	COLLET 4-26
028	020	28.71-29.80	COLLET 4-28
028	020	29.81-31.00	COLLET 4-28
030.5	022	31.01-32.10	COLLET 4-30.5
030.5	022	32.11-33.30	COLLET 4-30.5
033	024	33.31-34.80	COLLET 4-33
033	024	34.81-36.20	COLLET 4-33
035.5	026	36.21-37.30	COLLET 4-35.5
035.5	026	37.31-38.40	COLLET 4-35.5
035.5	026	38.41-39.60	COLLET 4-35.5
039	029	39.61-40.60	COLLET 4-39
039	029	40.61-41.80	COLLET 4-39
039	029	41.81-43.00	COLLET 4-39
042.5	032	43.01-44.30	COLLET 4-42.5
042.5	032	44.31-45.60	COLLET 4-42.5
042.5	032	45.61-47.00	COLLET 4-42.5
046.5	035	47.01-48.50	COLLET 4-46.5
046.5	035	48.51-50.10	COLLET 4-46.5
046.5	035	50.11-51.70	COLLET 4-46.5
051	039	51.71-53.20	COLLET 4-51
051	039	53.21-54.70	COLLET 4-51
051	039	54.71-56.20	COLLET 4-51
055.5	043A	56.21-58.40	COLLET 4-55.5
055.5	043A	58.41-60.60	COLLET 4-55.5
055.5	043A	60.61-62.80	COLLET 4-55.5
055.5	043A	62.81-65.00	COLLET 4-55.5

• Внутренняя труба должна быть длиннее наружной. Подробную информацию см. на стр. D130-D131

Соединительная муфта

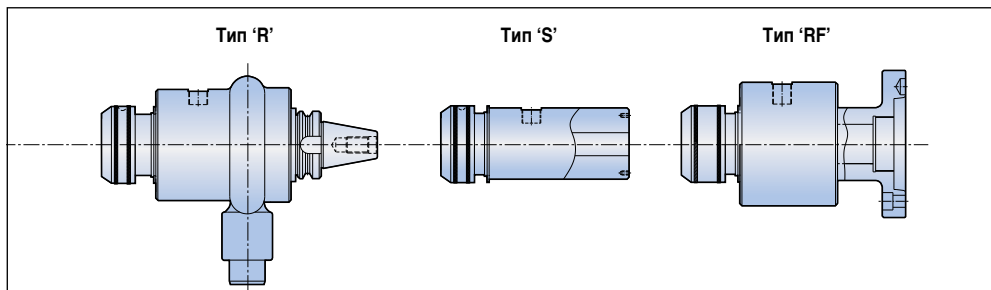

Уплотнительная втулка	Наружное уплотнительное кольцо	Внутреннее уплотнительное кольцо	Соединительная муфта
SEALING SLEEVE 4R-18	OOR 25.24	IOR18	DTC-4S/4R/4RF
SEALING SLEEVE 4R-18		IOR18	
SEALING SLEEVE 4R-19.5		IOR19.5	
SEALING SLEEVE 4R-19.5		IOR19.5	
SEALING SLEEVE 4R-21.5		IOR21.5	
SEALING SLEEVE 4R-21.5		IOR21.5	
SEALING SLEEVE 4R-23.5		IOR23.5	
SEALING SLEEVE 4R-23.5		IOR23.5	
SEALING SLEEVE 4R-26		IOR26	
SEALING SLEEVE 4R-26		IOR26	
SEALING SLEEVE 4R-28		IOR28	
SEALING SLEEVE 4R-28		IOR28	
SEALING SLEEVE 4R-30.5		IOR30.5	
SEALING SLEEVE 4R-30.5		IOR30.5	
SEALING SLEEVE 4R-33		IOR33	
SEALING SLEEVE 4R-33		IOR33	
SEALING SLEEVE 4R-35.5		IOR35.5	
SEALING SLEEVE 4R-35.5		IOR35.5	
SEALING SLEEVE 4R-35.5		IOR35.5	
SEALING SLEEVE 4R-39		IOR39	
SEALING SLEEVE 4R-39	IOR39		
SEALING SLEEVE 4R-39	IOR39		
SEALING SLEEVE 4R-42.5	IOR42.5		
SEALING SLEEVE 4R-42.5	IOR42.5		
SEALING SLEEVE 4R-42.5	IOR42.5		
SEALING SLEEVE 4R-46.5	IOR46.5		
SEALING SLEEVE 4R-46.5	IOR46.5		
SEALING SLEEVE 4R-46.5	IOR46.5		
SEALING SLEEVE 4R-51	IOR51		
SEALING SLEEVE 4R-51	IOR51		
SEALING SLEEVE 4R-51	IOR51		
SEALING SLEEVE 4R-55.5	IOR55.5		
SEALING SLEEVE 4R-55.5	IOR55.5		
SEALING SLEEVE 4R-55.5	IOR55.5		
SEALING SLEEVE 4R-55.5	IOR55.5		
SEALING SLEEVE 4R-55.5	IOR55.5		

• Внутренняя труба должна быть длиннее наружной. Подробную информацию см. на стр. D130-D131

Соединительная муфта, тип S

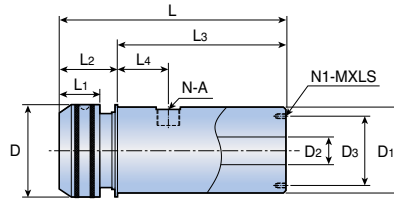

Обозначение	DC	D	D1	D2	D3	L	L1	L2	L3	L4	N-A	N1-MXLS
DTC 4S	18.4-65.0	115	100	45	80	310	50	60	250	68	2-PT3/4"	4-M8x15
5S	65.0-123.9	164	140	81	120	415	47	115	300		2-PT1"	6-M8x20

Соединительная муфта, тип R

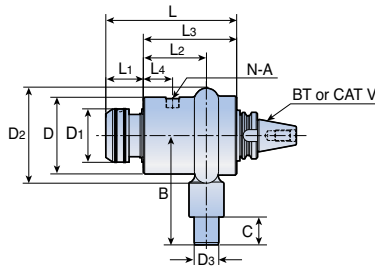

Обозначение	DC	D	D1	D2	D3	B	C	L	L1	L2	L3	L4	N-A
DTC 4R	18.4-65.0	165	115	206	53	186.5	60	319.7	59.2	152	228	75	2-PT1"
5R	65.0-123.9	225	164	312	100	310	100	382	62	201	320	95	2-PT1 1/4"
6R	124.0-183.9	350	244	445	152.4	412	120	487	75	250	412	118	4-PT1-1/4"

Соединительная муфта, тип RF

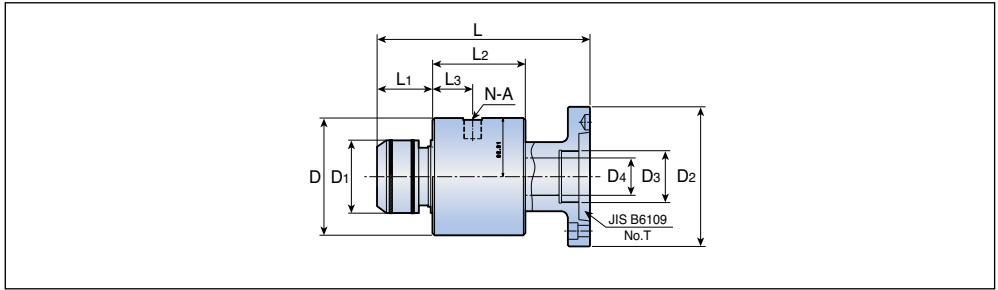

Обозначение	DC	D	D1	D2	D3	D4	L	L1	L2	L3	N-A
DTC 4RF	18.4-65.0	160	115	210	M62x2	46	291.5	64.5	150	75	2-PT1"

Цанга / Уплотнительная втулка

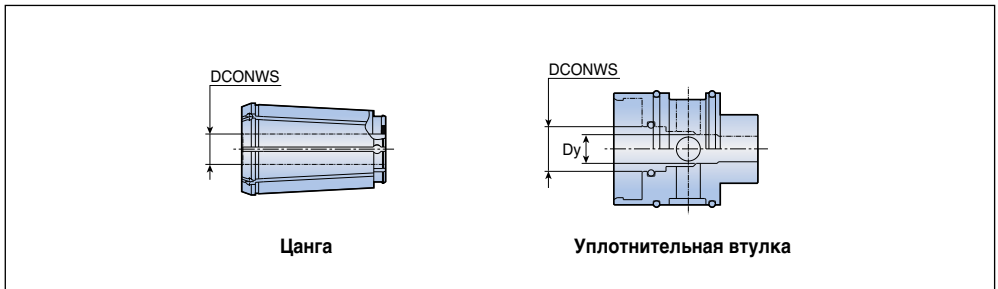

Цанга

Уплотнительная втулка

Обозначение	DC	DCONWS	Обозначение	DC	DCONWS	Dy	Наружное уплотнительное кольцо	Внутреннее уплотнительное кольцо
COLLET 4-18	18.40-20.00	18.0	SEALING SLEEVE	4-18	18.40-20.00	18.0	OOR 65	IOR 18
4-19.5	20.01-21.80	19.5		4-19.5	20.01-21.80	19.5		IOR 19.5
4-21.5	21.81-24.10	21.5		4-21.5	21.81-24.10	21.5		IOR 21.5
4-23.5	24.11-26.40	23.5		4-23.5	24.11-26.40	23.5		IOR 23.5
4-26	26.41-28.70	26.0		4-26	26.41-28.70	26.0		IOR 26
4-28	28.71-31.00	28.0		4-28	28.71-31.00	28.0		IOR 28
4-30.5	31.01-33.30	30.5		4-30.5	31.01-33.30	30.5		IOR 30.5
4-33	33.31-36.20	33.0		4-33	33.31-36.20	33.0		IOR 33
4-35.5	36.21-39.60	35.5		4-35.5	36.21-39.60	35.5		IOR 35.5
4-39	39.61-43.00	39.0		4-39	39.61-43.00	39.0		IOR 39
4-42.5	43.01-47.00	42.5		4-42.5	43.01-47.00	42.5		IOR 42.5
4-46.5	47.01-51.70	46.5		4-46.5	47.01-51.70	46.5		IOR 46.5
4-51	51.71-56.20	51.0		4-51	51.71-56.20	51.0		IOR 51
4-55.5	56.21-65.00	55.5		4-55.5	56.21-65.00	55.5		IOR 55.5

Стандартное ружейное сверло



• Глубина сверления: 10xDC - 25xDC

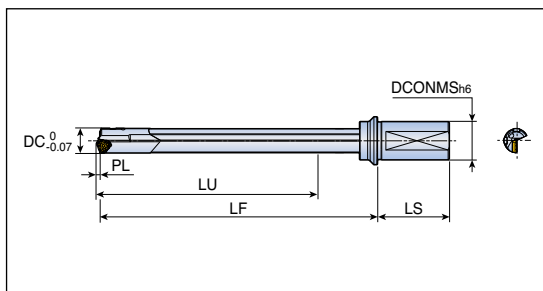

Обозначение	Размеры (мм)						
	DC	LU	LF	LS	DCONMS	PL	L/D
TRGD 16.00xM25-10	16.0	172	209	56	25	2.2	10
16.50xM25-10	16.5	172	209	56	25	2.2	10
17.00xM25-10	17.0	182	220	56	25	2.2	10
18.00xM25-10	18.0	193	232	56	25	3.0	10
19.00xM25-10	19.0	203	243	56	25	3.0	10
20.00xM32-10	20.0	213	255	60	32	3.2	10
14.00xM25-15	14.0	227	261	56	25	2.0	15
14.50xM25-15	14.5	227	262	56	25	2.0	15
15.00xM25-15	15.0	242	278	56	25	2.0	15
16.00xM25-15	16.0	257	294	56	25	2.2	15
16.50xM25-15	16.5	257	294	56	25	2.2	15
17.00xM25-15	17.0	272	310	56	25	2.2	15
17.50xM25-15	17.5	272	310	56	25	2.2	15
18.00xM25-15	18.0	288	327	56	25	3.0	15
18.50xM25-15	18.5	288	327	56	25	3.0	15
19.00xM25-15	19.0	303	343	56	25	3.0	15
19.50xM25-15	19.5	303	343	56	25	3.0	15
20.00xM32-15	20.0	318	360	60	32	3.2	15
21.00xM32-15	21.0	333	376	60	32	3.2	15
22.00xM32-15	22.0	348	393	60	32	3.4	15
23.00xM32-15	23.0	363	409	60	32	3.4	15
24.00xM32-15	24.0	378	426	60	32	3.4	15
25.00xM32-15	25.0	394	442	60	32	3.6	15
26.00xM40-15	26.0	409	449	70	40	3.6	15
27.00xM40-15	27.0	424	465	70	40	3.6	15
28.00xM40-15	28.0	424	467	70	40	3.6	15
14.00xM25-20	14.0	302	336	56	25	2.0	20
14.50xM25-20	14.5	302	337	56	25	2.0	20
15.00xM25-20	15.0	322	358	56	25	2.0	20
14.00xM25-25	14.0	377	411	56	25	2.0	25
14.50xM25-25	14.5	377	412	56	25	2.0	25
15.00xM25-25	15.0	402	438	56	25	2.0	25
16.00xM25-25	16.0	427	464	56	25	2.2	25
16.50xM25-25	16.5	427	464	56	25	2.2	25
17.00xM25-25	17.0	452	490	56	25	2.2	25



• Направляющие пластины необходимо заказывать дополнительно

• Доступно по запросу

Стандартное ружейное сверло



- Глубина сверления: 10xDC - 25xDC

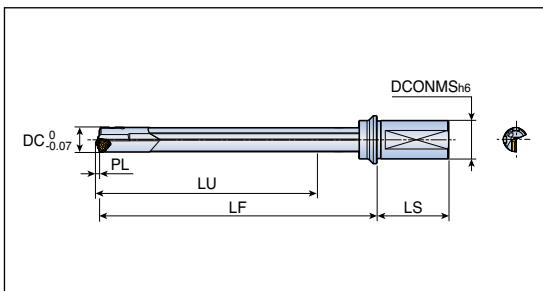

Обозначение	Размеры (мм)						
	DC	LU	LF	LS	DCONMS	PL	L/D
TRGD 17.50xM25-25	17.5	452	490	56	25	2.2	25
18.00xM25-25	18.0	478	517	56	25	3.0	25
18.50xM25-25	18.5	478	517	56	25	3.0	25
19.00xM25-25	19.0	503	543	56	25	3.0	25
19.50xM25-25	19.5	503	543	56	25	3.0	25
20.00xM32-25	20.0	528	570	60	32	3.2	25
21.00xM32-25	21.0	553	596	60	32	3.2	25
22.00xM32-25	22.0	578	623	60	32	3.4	25
23.00xM32-25	23.0	603	649	60	32	3.4	25
24.00xM32-25	24.0	628	676	60	32	3.4	25
25.00xM32-25	25.0	654	702	60	32	3.6	25
26.00xM40-25	26.0	679	719	70	40	3.6	25
27.00xM40-25	27.0	704	745	70	40	3.6	25
28.00xM40-25	28.0	704	747	70	40	3.6	25

- Направляющие пластины необходимо заказывать дополнительно

- Доступно по запросу

Режущие и направляющие пластины

Диаметр сверла (мм)	Пластина			Направляющая пластина		
	Пластина	Винт	Ключ	Направляющая пластина	Винт	Ключ
14.00-15.99	TOGT 070304 RS TT9030	SR14-560/S	T-8F	PAD-GO05-060CD-SA PAD-GO05-060CD-SB	SR34-508	T-7F
16.00-18.00	TOGT 080305 RS TT9030	SR14-560/S	T-8F	PAD-GO05-075CD-SA PAD-GO05-075CD-SB	SR34-508	T-7F
18.01-20.00	TOGT 090305 RS TT9030	CSTB2.5S*	T-8F	PAD-GO06-085CD-SA PAD-GO06-085CD-SB	CSTB2.2S*	T-7F
20.01-21.00	TOGT 100305 RS TT9030	CSTB3S*	T-9F			
21.01-21.99	TOGT 100305 RS TT9030	CSTB3S*	T-9F	PAD-GO06-100CD-SA PAD-GO06-100CD-SB	CSTB2.2S*	T-7F
22.00-25.00	TOGT 110405 RS TT9030	CSTB3.5H*	T-15F			
25.01-28.00	TOGT 120405 RS TT9030	CSTB4S*	T-15F	PAD-GO06CD-SA PAD-GO06CD-SB	CSTB2.2S*	T-7F



- Направляющие пластины в сплаве "SB" - первый выбор для общего применения. Направляющие пластины в сплаве "SA" применяются только если используется СОЖ на масляной основе.
- Режущие и направляющие пластины необходимо заказывать отдельно

Стандартное ружейное сверло



- Глубина сверления: 10xDC - 15xDC

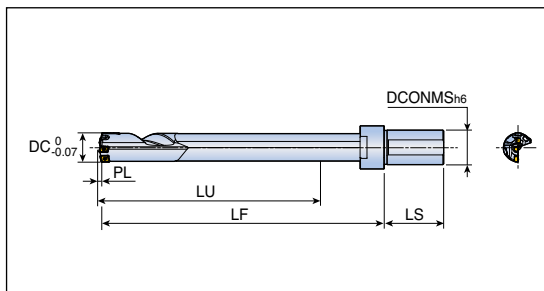

Обозначение	Размеры (мм)						
	DC	LU	LF	LS	DCONMS	PL	L/D
TRGD 29.00XFM40-10	29.0	293	360	69	40	2.6	10
30.00XFM40-10	30.0	313	383	69	40	2.9	10
31.00XFM40-10	31.0	313	383	69	40	2.9	10
32.00XFM40-10	32.0	323	395	69	40	3.0	10
33.00XFM40-10	33.0	333	406	69	40	3.1	10
34.00XFM40-10	34.0	343	418	69	40	3.0	10
35.00XFM40-10	35.0	353	428	69	40	3.1	10
36.00XFM40-10	36.0	363	441	69	40	3.1	10
29.00XFM40-15	29.0	438	505	69	40	2.6	15
30.00XFM40-15	30.0	468	538	69	40	2.9	15
31.00XFM40-15	31.0	468	538	69	40	2.9	15
32.00XFM40-15	32.0	483	555	69	40	3.0	15
33.00XFM40-15	33.0	498	571	69	40	3.1	15
34.00XFM40-15	34.0	513	588	69	40	3.0	15
35.00XFM40-15	35.0	528	603	69	40	3.1	15
36.00XFM40-15	36.0	543	621	69	40	3.1	15

- Направляющие пластины необходимо заказывать дополнительно
- Доступны сверла диаметром до 40.0 мм

- Доступно по запросу

Режущие и направляющие пластины

Комплектующие	Размеры (мм)				
	29.0-29.99	30.0-33.0	33.01-35.0	35.01-36.0	
Пластина	Наружная пластина	NPHT 06003RG	NPHT 07504RG	NPHT 07504RG	NPHT 07504RG
	Винт	CSTB2.2	CSTB2.5	CSTB2.5	CSTB2.5
	Ключ	T-7F	T-8F	T-8F	T-8F
	Внутренняя пластина	NPMT 05503RG	NPMT 06504RG	NPMT 06504RG	NPMT 06504RG
	Винт	CSTB2.2	CSTB2.5	CSTB2.5	CSTB2.5
	Ключ	T-7F	T-8F	T-8F	T-8F
	Центральная пластина	NPMT 06504LG	NPMT 06504LG	NPMT 06504LG	NPMT 08004LG
Направляющая пластина	Винт	CSTB2.5	CSTB2.6	CSTB2.7	CSTB2.8
	Ключ	T-8F	T-8F	T-8F	T-8F
	Направляющая пластина	PAD-GP06	PAD-GP06	PAD-GP07	PAD-GP07
	Винт	SR34-508	SR34-508	CSTB3.0S	CSTB3.0S
	Ключ	T-7F	T-7F	T-9F	T-9F



- Режущие и направляющие пластины необходимо заказывать отдельно

Стандартное ружейное сверло

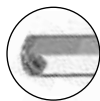

Глубина сверления: 10xDC - 25xDC

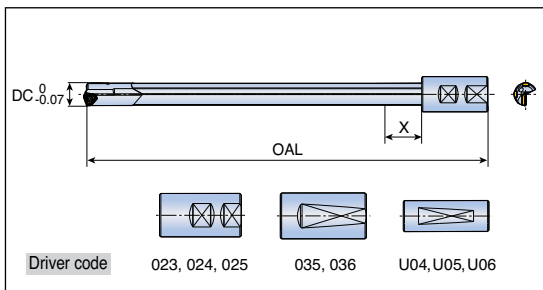

Обозначение	Код хвостовика	Размеры (мм)		
		DC	OAL	X
TRGDL 14.00X800-XXX	U04 023	14	800	21
14.00X1000-XXX		14	1000	21
14.00X1650-XXX		14	1650	21
14.50X800-XXX		14.5	800	22
14.50X1000-XXX		14.5	1000	22
14.50X1650-XXX		14.5	1650	22
15.00X800-XXX		15	800	23
15.00X1000-XXX		15	1000	23
15.00X1650-XXX		15	1650	23
16.00x800-XXX	U04 023 035	16	800	24
16.00x1000-XXX		16	1000	24
16.00x1500-XXX		16	1500	24
17.00x1000-XXX		17	1000	25
17.00x1500-XXX		17	1500	25
18.00x800-XXX		18	800	27
18.00x1000-XXX		18	1000	27
18.00x1500-XXX		18	1500	27
19.00x800-XXX		19	800	28
19.00x1000-XXX	19	1000	28	
19.00x1500-XXX	19	1500	28	
20.00x800-XXX	U05 024 036	20	800	30
20.00x1000-XXX		20	1000	30
20.00x1500-XXX		20	1500	30
21.00x1000-XXX		21	1000	31
21.00x1500-XXX		21	1500	31
22.00x1000-XXX		22	1000	33
22.00x1500-XXX		22	1500	33
23.00x1000-XXX		23	1000	34
23.00x1500-XXX		23	1500	34
24.00x1000-XXX		24	1000	36
24.00x1500-XXX		24	1500	36
25.00x1000-XXX	25	1000	37	
25.00x1500-XXX	25	1500	37	



• Направляющие пластины необходимо заказывать дополнительно

• Доступно по запросу
• Выберете код хвостовика "XXX"

Стандартное ружейное сверло

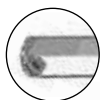

- Глубина сверления: 10xDC - 25xDC

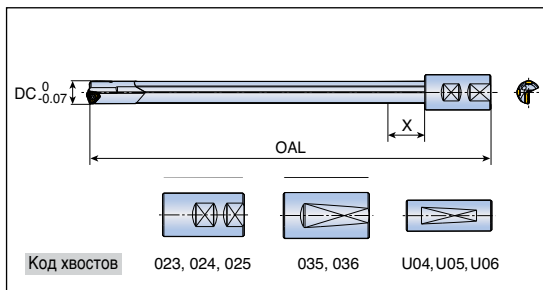

Обозначение	Код хвостовика	Размеры (мм)		
		DC	OAL	X
TRGDL 26.00x1000-XXX	U06 025 026 036	26	1000	39
26.00x1500-XXX		26	1500	39
27.00x1000-XXX		27	1000	40
27.00x1500-XXX		27	1500	40
28.00x1000-XXX		28	1000	42
28.00x1500-XXX		28	1500	42

- Направляющие пластины необходимо заказывать дополнительно

- Доступно по запросу
- Выберите код хвостовика "XXX"

Режущие и направляющие пластины

Диаметр сверла (мм)	Пластина			Направляющая пластина		
	Пластина	Винт	Ключ	Направляющая пластина	Винт	Ключ
14.00-15.99	TOGT 070304 RS TT9030	SR14-560/S	T-8F	PAD-GO05-060CD-SA PAD-GO05-060CD-SB	SR34-508	T-7F
16.00-18.00	TOGT 080305 RS TT9030	SR14-560/S	T-8F	PAD-GO05-075CD-SA PAD-GO05-075CD-SB	SR34-508	T-7F
18.01-20.00	TOGT 090305 RS TT9030	CSTB2.5S*	T-8F	PAD-GO06-085CD-SA PAD-GO06-085CD-SB	CSTB2.2S*	T-7F
20.01-21.00	TOGT 100305 RS TT9030	CSTB3S*	T-9F	PAD-GO06-100CD-SA PAD-GO06-100CD-SB	CSTB2.2S*	T-7F
21.01-21.99	TOGT 100305 RS TT9030	CSTB3S*	T-9F	PAD-GO06-100CD-SA PAD-GO06-100CD-SB	CSTB2.2S*	T-7F
22.00-25.00	TOGT 110405 RS TT9030	CSTB3.5H*	T-15F	PAD-GO06CD-SA PAD-GO06CD-SB	CSTB2.2S*	T-7F
25.01-28.00	TOGT 120405 RS TT9030	CSTB4S*	T-15F	PAD-GO06CD-SA PAD-GO06CD-SB	CSTB2.2S*	T-7F



- Направляющие пластины в сплаве "SB" - первый выбор для общего применения. Направляющие пластины в сплаве "SA" применяются только если используется СОЖ на масляной основе.
- Режущие и направляющие пластины необходимо заказывать отдельно

Хвостовик	Диаметр сверла	Код хвостовика	Размеры (мм)	
			LS	DCONMS
	14.00-19.69	023	56	25.00
	16.00-25.69	024	60	32.00
	16.00-28.00	025	70	40.00
	16.00-28.00	026	80	50.00
	16.00-19.69	035	56	25.00
	16.00-25.69	036	60	32.00
	16.00-19.69	U04	70	25.40
	16.00-25.69	U05	70	31.75
	16.00-28.00	U06	70	38.10

Сменные пластины и головки для свёрл

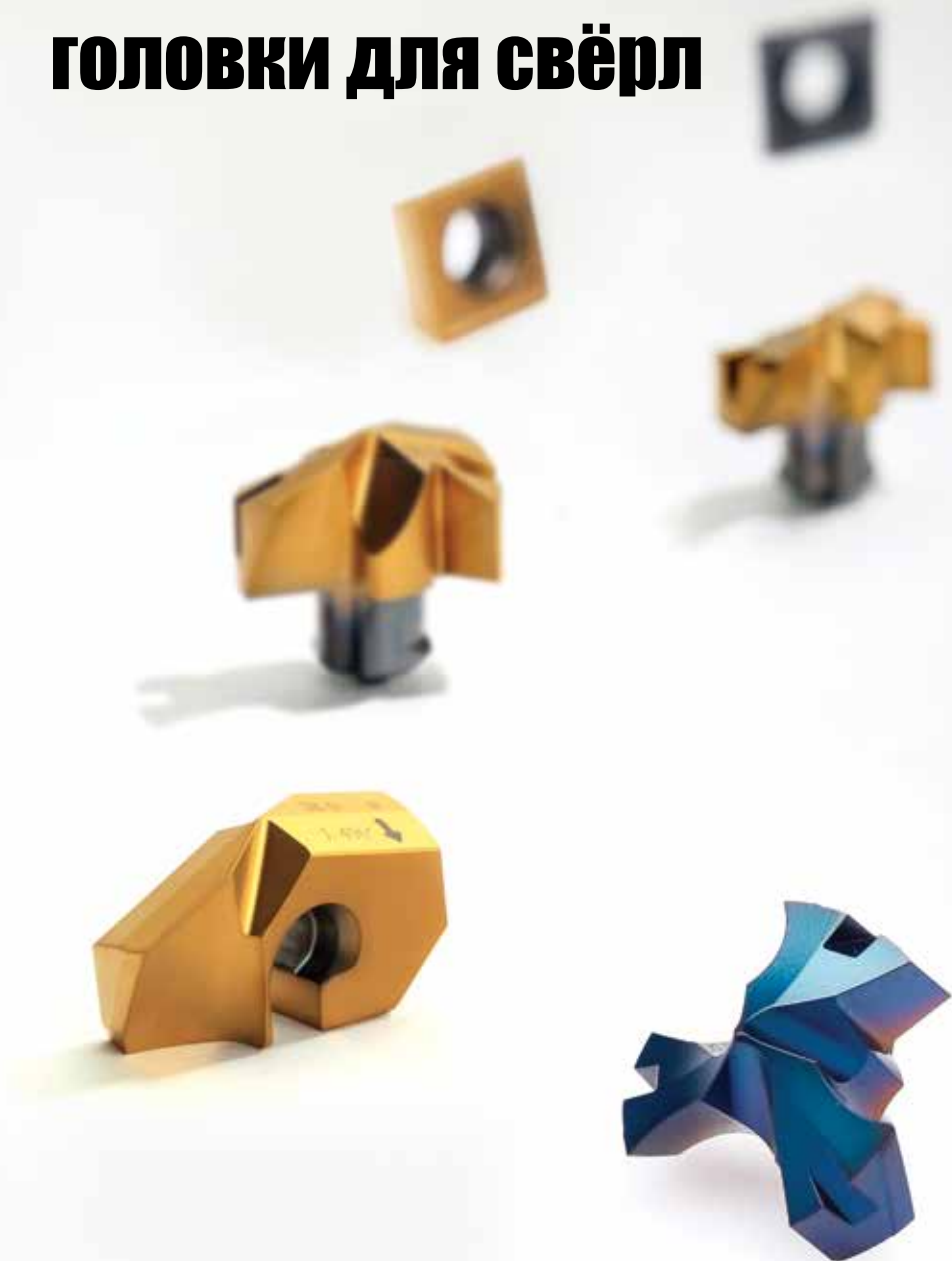

Пластина для общего применения

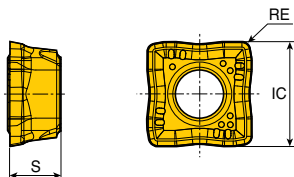

Габарит	Размеры (мм)		
	IC	S	RE
04	4.4	2.38	0.4
05	4.9	2.38	0.4
06	5.7	2.38	0.4
07	6.8	2.80	0.6
08	7.9	3.97	0.6
09	9.2	3.97	0.8
11	11.0	3.97	0.8
13	12.8	4.40	0.8
15	15.0	4.80	1.0

Пластина	Обозначение	С покрытием						Без покрытия	
		TT9080	TT8020	TT9300	TT9030	TT6030	TT7400	K10	
	SOMT 040204 DP	●	●	●					
	050204 DP	●	●	●					
	060204 DP	●	●	●					
	070306 DP	●	●	●					
	08T306 DP	●	●	●					
	09T308 DP	●	●	●					
	11T308 DP	●	●	●					
	130408 DP	●	●	●					
	150510 DP	●	●	●					



- TT9080: Для общего применения
- TT8020: Для нестабильных условий
- TT9300: Для высокоскоростной обработки стали (ТОЛЬКО периферийные пластины)

●: Стандартная позиция

SOMT...DL

Пластина для низкоуглеродистой стали

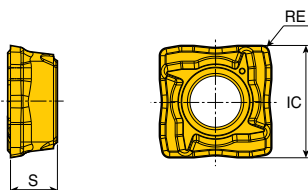

Габарит	Размеры (мм)		
	IC	S	RE
05	4.9	2.38	0.4
06	5.7	2.38	0.4
07	6.8	2.80	0.6
08	7.9	3.97	0.6
09	9.2	3.97	0.8
11	11.0	3.97	0.8
13	12.8	4.40	0.8
15	15.0	4.80	1.0

Пластина	Обозначение	С покрытием						Без покрытия	
		TT9080	TT9030	TT8020	TT6030	TT9300	TT7400	K10	
	SOMT 050204 DL	●							
	060204 DL	●							
	070306 DL	●							
	08T306 DL	●							
	09T308 DL	●							
	11T308 DL	●							
	130408 DL	●							
	150510 DL	●							



- TT9080: Для общего применения

●: Стандартная позиция

SOMT...DK

Пластина для чугуна

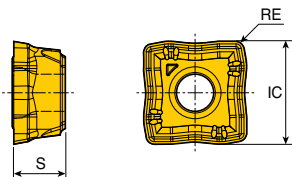

Габарит	Размеры (мм)		
	IC	S	RE
05	4.9	2.38	0.4
06	5.7	2.38	0.4
07	6.8	2.80	0.6
08	7.9	3.97	0.6
09	9.2	3.97	0.8
11	11.0	3.97	0.8
13	12.8	4.40	0.8
15	15.0	4.80	1.0

Пластина	Обозначение	С покрытием						Без покрытия	
		TT9080	TT8020	TT9300	TT9030	TT6030	TT6080	TT7400	K10
	SOMT 050204 DK						•		
	060204 DK						•		
	070306 DK						•		
	08T306 DK						•		
	09T308 DK						•		
	11T308 DK						•		
	130408 DK						•		
	150510 DK						•		



•: Стандартная позиция

SOMT...DA

Пластина для алюминиевых сплавов

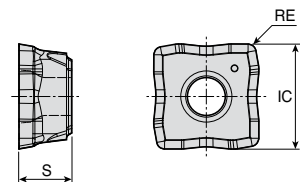

Габарит	Размеры (мм)		
	IC	S	RE
05	4.9	2.38	0.4
06	5.7	2.38	0.4
07	6.8	2.80	0.6
08	7.9	3.97	0.6
09	9.2	3.97	0.8
11	11.0	3.97	0.8
13	12.8	4.40	0.8
15	15.0	4.80	1.0

Пластина	Обозначение	С покрытием						Без покрытия	
		TT9080	TT8020	TT9300	TT9030	TT6030	TT6080	TT7400	K10
	SOMT 050204 DA							•	
	060204 DA							•	
	070306 DA							•	
	08T306 DA							•	
	09T308 DA							•	
	11T308 DA							•	
	130408 DA							•	
	150510 DA							•	



•: Стандартная позиция

Пластина для общего применения

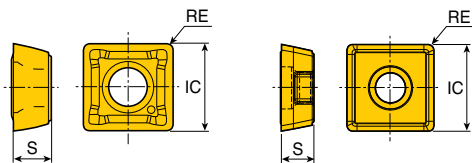

SPMG 120408 DG

Габарит	Размеры (мм)		
	IC	S	RE
05	5.00	2.38	0.4
06	6.00	2.38	0.4
07	7.94	3.97	0.8
09	9.80	4.30	0.8
11	11.50	4.80	0.8
12	12.70	4.76	0.8
14	14.30	5.20	1.2

Пластина	Обозначение	С покрытием						Без покрытия	
		TT9080	TT9030	TT8020	TT6030	TT9300	TT7400	K10	
	SPMG 050204 DG		●	●		●			
	060204 DG		●	●		●			
	07T308 DG		●	●		●			
	090408 DG		●	●		●			
	110408 DG		●	●		●			
	120408 DG		●						
	140512 DG		●	●			●		



- TT9030: Для общего применения
- TT8020: Для нестабильных условий
- TT7400: Для высокоскоростной обработки стали (ТОЛЬКО периферийные пластины)
- Стандартная позиция

SPMG...DK

Пластина для чугуна

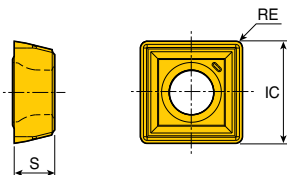

Габарит	Размеры (мм)		
	IC	S	RE
05	5.00	2.38	0.4
06	6.00	2.38	0.4
07	7.94	3.97	0.8
09	9.80	4.30	0.8
11	11.50	4.80	0.8
14	14.30	5.20	1.2

Пластина	Обозначение	С покрытием						Без покрытия	
		TT9080	TT9030	TT8020	TT6030	TT9300	TT7400	K10	
	SPMG 050204 DK				●				
	060204 DK				●				
	07T308 DK				●				
	090408 DK				●				
	110408 DK				●				
	140512 DK				●				



- Стандартная позиция

Пластина для алюминиевых сплавов

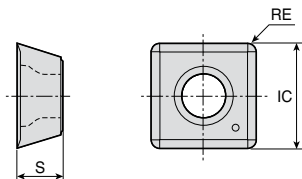

Габарит	Размеры (мм)		
	IC	S	RE
05	5.00	2.38	0.4
06	6.00	2.38	0.4
07	7.94	3.97	0.8
09	9.80	4.30	0.8
11	11.50	4.80	0.8
14	14.30	5.20	1.2

Пластина	Обозначение	С покрытием						Без покрытия	
		TT9080	TT9030	TT8020	TT6030	TT9300	TT7400	K10	
	SPGG 050204 DA							●	
	060204 DA							●	
	07T308 DA							●	
	090408 DA							●	
	110408 DA							●	
	140512 DA							●	



●: Стандартная позиция

3ED...-P+

Трехкромочная сверлильная головка

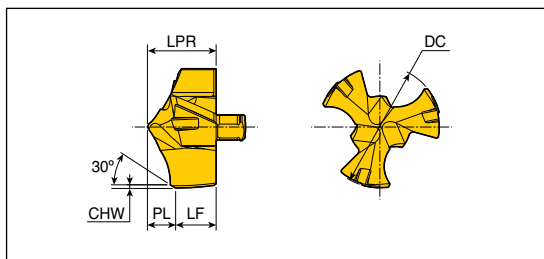

Обозначение	Размеры (мм)						Сплав
	DC	LPR	PL	LF	CHW	SSC	
3ED-160-P+	16.0	9.00	3.70	5.30	0.40	16	●
165-P+	16.5	9.00	3.71	5.29	0.40	16	●
170-P+	17.0	9.50	3.88	5.62	0.40	17	●
175-P+	17.5	9.50	3.89	5.61	0.40	17	●
180-P+	18.0	10.10	4.07	6.03	0.40	18	●
185-P+	18.5	10.10	4.08	6.02	0.40	18	●
190-P+	19.0	10.70	4.26	6.44	0.40	19	●
195-P+	19.5	10.70	4.27	6.43	0.40	19	●
200-P+	20.0	11.30	4.44	6.86	0.40	20	●
205-P+	20.5	11.30	4.45	6.85	0.40	20	●



● SSC : Размер кармана

●: Стандартная позиция

Сверлильная головка

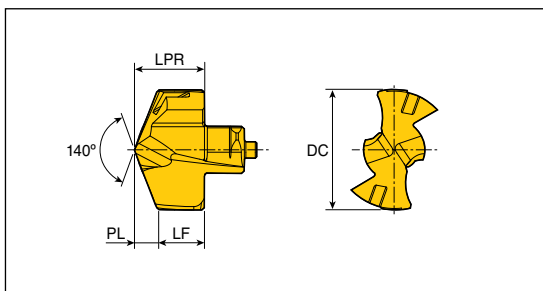

Обозначение	Размеры (мм)					Сплав
	DC	LPR	PL	LF	SSC	TT9080
TCD - 060-P/M/K	6.0	4.0	0.96	3.04	6	●
061-P/M/K	6.1	4.0	0.98	3.02	6	●
062-P/M/K	6.2	4.0	1.00	3.00	6	●
063-P/M/K	6.3	4.0	1.01	2.99	6	●
064-P/M/K	6.4	4.0	1.03	2.97	6	●
065-P/M/K	6.5	4.3	1.18	3.12	6.5	●
066-P/M/K	6.6	4.3	1.20	3.10	6.5	●
067-P/M/K	6.7	4.3	1.22	3.08	6.5	●
068-P/M/K	6.8	4.3	1.23	3.07	6.5	●
069-P/M/K	6.9	4.3	1.25	3.05	6.5	●
070-P/M/K	7.0	4.6	1.01	3.59	7	●
071-P/M/K	7.1	4.6	1.03	3.57	7	●
072-P/M/K	7.2	4.6	1.05	3.55	7	●
073-P/M/K	7.3	4.6	1.06	3.54	7	●
074-P/M/K	7.4	4.6	1.08	3.52	7	●
075-P/M/K	7.5	4.6	1.10	3.50	7	●
076-P/M/K	7.6	4.6	1.12	3.48	7	●
077-P/M/K	7.7	4.6	1.14	3.46	7	●
078-P/M/K	7.8	4.6	1.16	3.44	7	●
079-P/M/K	7.9	4.6	1.17	3.43	7	●
080-P/M/K	8.0	5.4	1.20	4.20	8	●
081-P/M/K	8.1	5.4	1.22	4.18	8	●
082-P/M/K	8.2	5.4	1.24	4.16	8	●
083-P/M/K	8.3	5.4	1.25	4.15	8	●
084-P/M/K	8.4	5.4	1.27	4.13	8	●
085-P/M/K	8.5	5.4	1.29	4.11	8	●
086-P/M/K	8.6	5.4	1.31	4.09	8	●
087-P/M/K	8.7	5.4	1.33	4.07	8	●
088-P/M/K	8.8	5.4	1.35	4.05	8	●
089-P/M/K	8.9	5.4	1.36	4.04	8	●
090-P/M/K	9.0	5.8	1.35	4.45	9	●
091-P/M/K	9.1	5.8	1.37	4.43	9	●
092-P/M/K	9.2	5.8	1.39	4.41	9	●
093-P/M/K	9.3	5.8	1.40	4.40	9	●
094-P/M/K	9.4	5.8	1.42	4.38	9	●



● Сверлильная головка может быть заказана по применению
 Пример заказа) Сверлильная головка D10.0 мм для
 обработки материалов группы P по ISO TCD-100-P TT9080

●: Стандартная позиция



● Чугун

TCD...P/M/K

Сверлильная головка

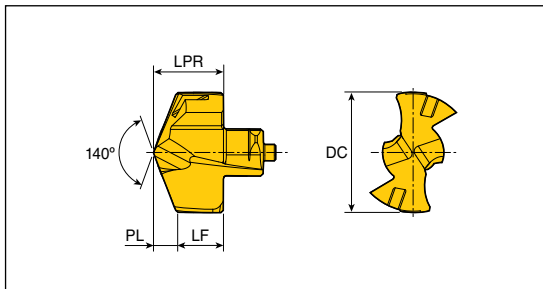

Обозначение	Размеры (мм)					Сплав
	DC	LPR	PL	LF	SSC	TT9080
TCD - 095-P/M/K	9.5	5.8	1.44	4.36	9	●
096-P/M/K	9.6	5.8	1.46	4.34	9	●
097-P/M/K	9.7	5.8	1.48	4.32	9	●
098-P/M/K	9.8	5.8	1.50	4.30	9	●
099-P/M/K	9.9	5.8	1.51	4.29	9	●
100-P/M/K	10.0	6.2	1.50	4.70	10	●
101-P/M/K	10.1	6.2	1.52	4.68	10	●
102-P/M/K	10.2	6.2	1.54	4.66	10	●
103-P/M/K	10.3	6.2	1.55	4.65	10	●
104-P/M/K	10.4	6.2	1.57	4.63	10	●
105-P/M/K	10.5	6.2	1.59	4.61	10	●
106-P/M/K	10.6	6.2	1.61	4.59	10	●
107-P/M/K	10.7	6.2	1.63	4.57	10	●
108-P/M/K	10.8	6.2	1.65	4.55	10	●
109-P/M/K	10.9	6.2	1.66	4.54	10	●
110-P/M/K	11.0	6.6	1.67	4.93	11	●
111-P/M/K	11.1	6.6	1.69	4.91	11	●
112-P/M/K	11.2	6.6	1.71	4.89	11	●
113-P/M/K	11.3	6.6	1.72	4.88	11	●
114-P/M/K	11.4	6.6	1.74	4.86	11	●
115-P/M/K	11.5	6.6	1.76	4.84	11	●
116-P/M/K	11.6	6.6	1.78	4.82	11	●
117-P/M/K	11.7	6.6	1.80	4.80	11	●
118-P/M/K	11.8	6.6	1.82	4.78	11	●
119-P/M/K	11.9	6.6	1.83	4.77	11	●
120-P/M/K	12.0	7.0	1.82	5.18	12	●
121-P/M/K	12.1	7.0	1.84	5.16	12	●
122-P/M/K	12.2	7.0	1.86	5.14	12	●
123-P/M/K	12.3	7.0	1.87	5.13	12	●
124-P/M/K	12.4	7.0	1.89	5.11	12	●
125-P/M/K	12.5	7.0	1.91	5.09	12	●
126-P/M/K	12.6	7.0	1.93	5.07	12	●
127-P/M/K	12.7	7.0	1.95	5.05	12	●
128-P/M/K	12.8	7.0	1.97	5.03	12	●
129-P/M/K	12.9	7.0	1.98	5.02	12	●



● Сверлильная головка может быть заказана по применению (Пример заказа) Сверлильная головка D10.0 мм для обработки материалов группы P по ISO TCD-100-P TT9080

● Стандартная позиция



Сталь Нержавеющая сталь Чугун

Сверлильная головка

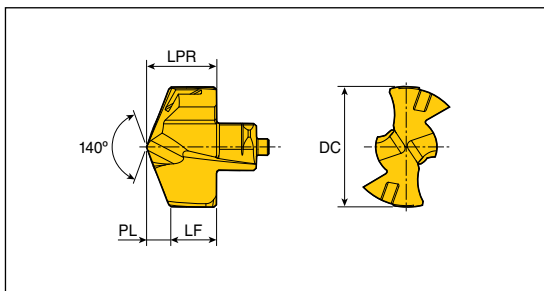

Обозначение	Размеры (мм)					Сплав
	DC	LPR	PL	LF	SSC	TT9080
TCD - 130-P/M/K	13.0	7.6	1.96	5.64	13	●
131-P/M/K	13.1	7.6	1.98	5.62	13	●
132-P/M/K	13.2	7.6	2.00	5.60	13	●
133-P/M/K	13.3	7.6	2.01	5.59	13	●
134-P/M/K	13.4	7.6	2.03	5.57	13	●
135-P/M/K	13.5	7.6	2.05	5.55	13	●
136-P/M/K	13.6	7.6	2.07	5.53	13	●
137-P/M/K	13.7	7.6	2.09	5.51	13	●
138-P/M/K	13.8	7.6	2.11	5.49	13	●
139-P/M/K	13.9	7.6	2.12	5.48	13	●
140-P/M/K	14.0	8.1	2.12	5.98	14	●
141-P/M/K	14.1	8.1	2.14	5.96	14	●
142-P/M/K	14.2	8.1	2.16	5.94	14	●
143-P/M/K	14.3	8.1	2.17	5.93	14	●
144-P/M/K	14.4	8.1	2.19	5.91	14	●
145-P/M/K	14.5	8.1	2.21	5.89	14	●
146-P/M/K	14.6	8.1	2.23	5.87	14	●
147-P/M/K	14.7	8.1	2.25	5.85	14	●
148-P/M/K	14.8	8.1	2.27	5.83	14	●
149-P/M/K	14.9	8.1	2.28	5.82	14	●
150-P/M/K	15.0	8.7	2.27	6.43	15	●
151-P/M/K	15.1	8.7	2.29	6.41	15	●
152-P/M/K	15.2	8.7	2.31	6.39	15	●
153-P/M/K	15.3	8.7	2.32	6.38	15	●
154-P/M/K	15.4	8.7	2.34	6.36	15	●
155-P/M/K	15.5	8.7	2.36	6.34	15	●
156-P/M/K	15.6	8.7	2.38	6.32	15	●
157-P/M/K	15.7	8.7	2.40	6.30	15	●
158-P/M/K	15.8	8.7	2.42	6.28	15	●
159-P/M/K	15.9	8.7	2.43	6.27	15	●
160-P/M/K	16.0	9.3	2.42	6.88	16	●
161-P/M/K	16.1	9.3	2.44	6.86	16	●
162-P/M/K	16.2	9.3	2.46	6.84	16	●
163-P/M/K	16.3	9.3	2.47	6.83	16	●
164-P/M/K	16.4	9.3	2.49	6.81	16	●



● Сверлильная головка может быть заказана по применению
 Пример заказа) Сверлильная головка D10.0 мм для
 обработки материалов группы P по ISO TCD-100-P TT9080

●: Стандартная позиция



Сталь Нержавеющая сталь Чугун

Сверлильная головка

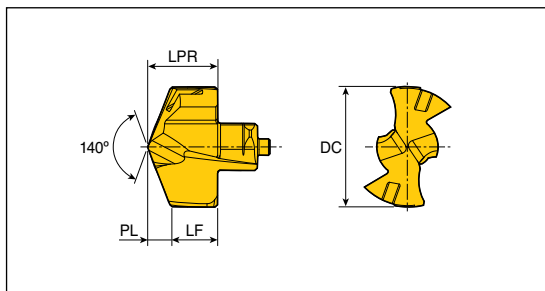

Обозначение	Размеры (мм)					Сплав
	DC	LPR	PL	LF	SSC	TT9080
TCD - 165-P/M/K	16.5	9.3	2.51	6.79	16	●
166-P/M/K	16.6	9.3	2.53	6.77	16	●
167-P/M/K	16.7	9.3	2.55	6.75	16	●
168-P/M/K	16.8	9.3	2.57	6.73	16	●
169-P/M/K	16.9	9.3	2.58	6.72	16	●
170-P/M/K	17.0	9.9	2.59	7.31	17	●
171-P/M/K	17.1	9.9	2.61	7.29	17	●
172-P/M/K	17.2	9.9	2.63	7.27	17	●
173-P/M/K	17.3	9.9	2.64	7.26	17	●
174-P/M/K	17.4	9.9	2.66	7.24	17	●
175-P/M/K	17.5	9.9	2.68	7.22	17	●
176-P/M/K	17.6	9.9	2.70	7.20	17	●
177-P/M/K	17.7	9.9	2.72	7.18	17	●
178-P/M/K	17.8	9.9	2.74	7.16	17	●
179-P/M/K	17.9	9.9	2.75	7.15	17	●
180-P/M/K	18.0	10.5	2.73	7.77	18	●
181-P/M/K	18.1	10.5	2.75	7.75	18	●
182-P/M/K	18.2	10.5	2.77	7.73	18	●
183-P/M/K	18.3	10.5	2.78	7.72	18	●
184-P/M/K	18.4	10.5	2.80	7.70	18	●
185-P/M/K	18.5	10.5	2.82	7.68	18	●
186-P/M/K	18.6	10.5	2.84	7.66	18	●
187-P/M/K	18.7	10.5	2.86	7.64	18	●
188-P/M/K	18.8	10.5	2.88	7.62	18	●
189-P/M/K	18.9	10.5	2.89	7.61	18	●
190-P/M/K	19.0	11.0	2.88	8.12	19	●
191-P/M/K	19.1	11.0	2.90	8.10	19	●
192-P/M/K	19.2	11.0	2.92	8.08	19	●
193-P/M/K	19.3	11.0	2.93	8.07	19	●
194-P/M/K	19.4	11.0	2.95	8.05	19	●
195-P/M/K	19.5	11.0	2.97	8.03	19	●
196-P/M/K	19.6	11.0	2.99	8.01	19	●
197-P/M/K	19.7	11.0	3.01	7.99	19	●
198-P/M/K	19.8	11.0	3.03	7.97	19	●
199-P/M/K	19.9	11.0	3.04	7.96	19	●



● Сверлильная головка может быть заказана по применению (Пример заказа) Сверлильная головка D10.0 мм для обработки материалов группы P по ISO TCD-100-P TT9080

● Стандартная позиция

P Сталь **M** Нержавеющая сталь **K** Чугун

Сверлильная головка

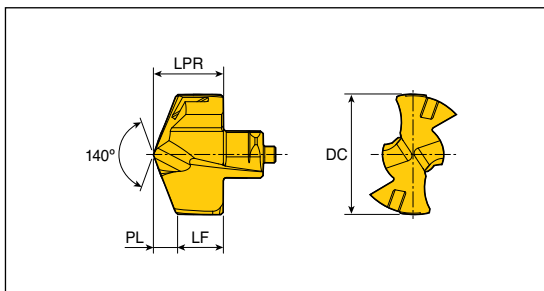

Обозначение	Размеры (мм)					Сплав TT9080
	DC	LPR	PL	LF	SSC	
TCD - 200-P/M/K	20.0	11.6	3.02	8.58	20	●
201-P/M/K	20.1	11.6	3.04	8.56	20	●
202-P/M/K	20.2	11.6	3.06	8.54	20	●
203-P/M/K	20.3	11.6	3.07	8.53	20	●
204-P/M/K	20.4	11.6	3.09	8.51	20	●
205-P/M/K	20.5	11.6	3.11	8.49	20	●
206-P/M/K	20.6	11.6	3.13	8.47	20	●
207-P/M/K	20.7	11.6	3.15	8.45	20	●
208-P/M/K	20.8	11.6	3.17	8.43	20	●
209-P/M/K	20.9	11.6	3.18	8.42	20	●
210-P/M/K	21.0	12.1	3.18	8.92	21	●
211-P/M/K	21.1	12.1	3.20	8.90	21	●
212-P/M/K	21.2	12.1	3.22	8.88	21	●
213-P/M/K	21.3	12.1	3.23	8.87	21	●
214-P/M/K	21.4	12.1	3.25	8.85	21	●
215-P/M/K	21.5	12.1	3.27	8.83	21	●
216-P/M/K	21.6	12.1	3.29	8.81	21	●
217-P/M/K	21.7	12.1	3.31	8.79	21	●
218-P/M/K	21.8	12.1	3.33	8.77	21	●
219-P/M/K	21.9	12.1	3.34	8.76	21	●
220-P/M/K	22.0	12.7	3.24	9.46	22	●
221-P/M/K	22.1	12.7	3.26	9.44	22	●
222-P/M/K	22.2	12.7	3.28	9.42	22	●
223-P/M/K	22.3	12.7	3.29	9.41	22	●
224-P/M/K	22.4	12.7	3.31	9.39	22	●
225-P/M/K	22.5	12.7	3.33	9.37	22	●
226-P/M/K	22.6	12.7	3.35	9.35	22	●
227-P/M/K	22.7	12.7	3.37	9.33	22	●
228-P/M/K	22.8	12.7	3.39	9.31	22	●
229-P/M/K	22.9	12.7	3.40	9.30	22	●
230-P/M/K	23.0	13.3	3.46	9.84	23	●
231-P/M/K	23.1	13.3	3.48	9.82	23	●
232-P/M/K	23.2	13.3	3.50	9.80	23	●
233-P/M/K	23.3	13.3	3.51	9.79	23	●
234-P/M/K	23.4	13.3	3.53	9.77	23	●



● Сверлильная головка может быть заказана по применению
 Пример заказа) Сверлильная головка D10.0 мм для
 обработки материалов группы P по ISO TCD-100-P TT9080

●: Стандартная позиция



Сверлильная головка

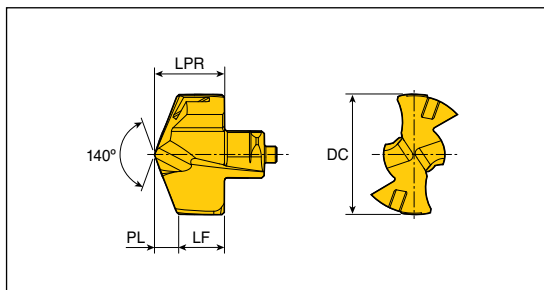

Обозначение	Размеры (мм)					Сплав
	DC	LPR	PL	LF	SSC	TT9080
TCD - 235-P/M/K	23.5	13.3	3.55	9.75	23	●
236-P/M/K	23.6	13.3	3.57	9.73	23	●
237-P/M/K	23.7	13.3	3.59	9.71	23	●
238-P/M/K	23.8	13.3	3.61	9.69	23	●
239-P/M/K	23.9	13.3	3.62	9.68	23	●
240-P/M/K	24.0	13.9	3.62	10.28	24	●
241-P/M/K	24.1	13.9	3.64	10.26	24	●
242-P/M/K	24.2	13.9	3.66	10.24	24	●
243-P/M/K	24.3	13.9	3.67	10.23	24	●
244-P/M/K	24.4	13.9	3.69	10.21	24	●
245-P/M/K	24.5	13.9	3.71	10.19	24	●
246-P/M/K	24.6	13.9	3.73	10.17	24	●
247-P/M/K	24.7	13.9	3.75	10.15	24	●
248-P/M/K	24.8	13.9	3.77	10.13	24	●
249-P/M/K	24.9	13.9	3.78	10.12	24	●
250-P/M/K	25.0	14.5	3.80	10.70	25	●
251-P/M/K	25.1	14.5	3.82	10.68	25	●
252-P/M/K	25.2	14.5	3.84	10.66	25	●
253-P/M/K	25.3	14.5	3.85	10.65	25	●
254-P/M/K	25.4	14.5	3.87	10.63	25	●
255-P/M/K	25.5	14.5	3.89	10.61	25	●
256-P/M/K	25.6	14.5	3.91	10.59	25	●
257-P/M/K	25.7	14.5	3.93	10.57	25	●
258-P/M/K	25.8	14.5	3.95	10.55	25	●
259-P/M/K	25.9	14.5	3.96	10.54	25	●



● Сверлильная головка может быть заказана по применению (Пример заказа) Сверлильная головка D10.0 мм для обработки материалов группы P по ISO TCD-100-P TT9080

● Стандартная позиция



Сталь



Нержавеющая сталь



Чугун

Сверлильная головка для алюминиевых сплавов

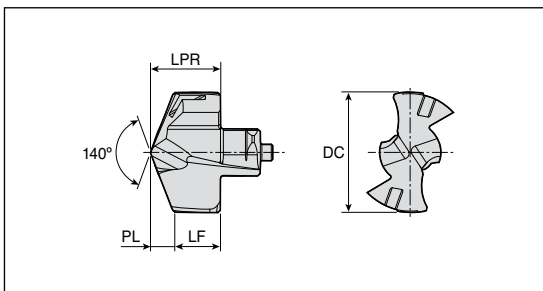

Обозначение	Размеры (мм)					Сплав	
	DC	LPR	PL	LF	SSC	UF10	
TCD - 060-N	6.0	4.00	0.96	3.04	6	●	
065-N	6.5	4.30	1.18	3.12	6.5	●	
070-N	7.0	4.60	1.01	3.59	7	●	
075-N	7.5	4.60	1.10	3.50	7	●	
080-N	8.0	5.40	1.20	4.20	8	●	
085-N	8.5	5.40	1.29	4.11	8	●	
090-N	9.0	5.80	1.35	4.45	9	●	
095-N	9.5	5.80	1.44	4.36	9	●	
100-N	10.0	6.20	1.50	4.70	10	●	
105-N	10.5	6.20	1.59	4.61	10	●	
110-N	11.0	6.60	1.67	4.93	11	●	
115-N	11.5	6.60	1.76	4.84	11	●	
120-N	12.0	7.00	1.82	5.18	12	●	
125-N	12.5	7.00	1.91	5.09	12	●	
130-N	13.0	7.60	1.96	5.64	13	●	
135-N	13.5	7.60	2.05	5.55	13	●	
140-N	14.0	8.15	2.12	6.03	14	●	
145-N	14.5	8.15	2.21	5.94	14	●	
150-N	15.0	8.73	2.27	6.46	15	●	
155-N	15.5	8.73	2.36	6.37	15	●	
160-N	16.0	9.30	2.42	6.88	16	●	
165-N	16.5	9.30	2.51	6.79	16	●	
170-N	17.0	9.90	2.59	7.31	17	●	
175-N	17.5	9.90	2.68	7.22	17	●	
180-N	18.0	10.50	2.73	7.77	18	●	
185-N	18.5	10.50	2.82	7.68	18	●	
190-N	19.0	11.00	2.88	8.12	19	●	
195-N	19.5	11.00	2.97	8.03	19	●	



● SSC : Размер кармана

● Стандартная позиция

N Цветные металлы

Самоцентрирующаяся сверлильная головка

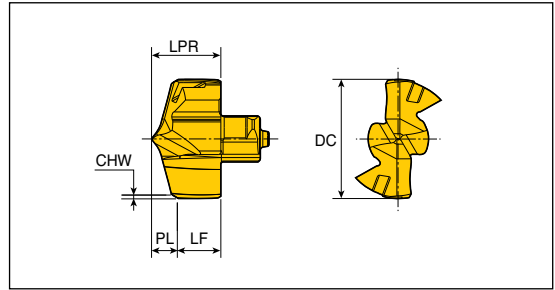

Обозначение	Размеры (мм)						Сплав TT9080
	DC	LPR	PL	LF	CHW	SSC	
TCD-060-P+	6.0	4.00	1.46	2.54	0.27	6	●
065-P+	6.5	4.30	1.55	2.75	0.27	6.5	●
068-P+	6.8	4.30	1.59	2.71	0.27	6.5	●
070-P+	7.0	4.60	1.64	2.96	0.27	7	●
075-P+	7.5	4.60	1.71	2.89	0.27	7	●
080-P+	8.0	5.40	1.81	3.59	0.27	8	●
085-P+	8.5	5.40	1.88	3.52	0.27	8	●
086-P+	8.6	5.40	1.89	3.51	0.27	8	●
090-P+	9.0	5.80	1.98	3.82	0.27	9	●
095-P+	9.5	5.80	2.05	3.75	0.27	9	●
099-P+	9.9	5.80	2.10	3.70	0.27	9	●
100-P+	10.0	6.20	2.33	3.87	0.38	10	●
102-P+	10.2	6.20	2.36	3.84	0.38	10	●
103-P+	10.3	6.20	2.37	3.83	0.38	10	●
105-P+	10.5	6.20	2.40	3.80	0.38	10	●
107-P+	10.7	6.20	2.42	3.78	0.38	10	●
108-P+	10.8	6.20	2.44	3.76	0.38	10	●
110-P+	11.0	6.60	2.50	4.10	0.38	11	●
111-P+	11.1	6.60	2.51	4.09	0.38	11	●
115-P+	11.5	6.60	2.57	4.03	0.38	11	●
120-P+	12.0	7.00	2.67	4.33	0.38	12	●
123-P+	12.3	7.00	2.71	4.29	0.38	12	●
125-P+	12.5	7.00	2.74	4.26	0.38	12	●
126-P+	12.6	7.00	2.75	4.25	0.38	12	●
127-P+	12.7	7.00	2.76	4.24	0.38	12	●
130-P+	13.0	7.60	2.85	4.75	0.38	13	●
135-P+	13.5	7.60	2.92	4.68	0.38	13	●
140-P+	14.0	8.15	3.02	5.13	0.38	14	●
141-P+	14.1	8.15	3.03	5.12	0.38	14	●
142-P+	14.2	8.15	3.05	5.10	0.38	14	●
143-P+	14.3	8.15	3.06	5.09	0.38	14	●
145-P+	14.5	8.15	3.09	5.06	0.38	14	●
146-P+	14.6	8.15	3.10	5.05	0.38	14	●
150-P+	15.0	8.73	3.19	5.54	0.38	15	●



● SSC : Размер кармана

● : Стандартная позиция

Самоцентрирующаяся сверлильная головка

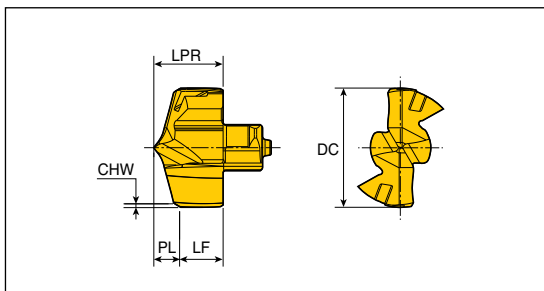

Обозначение	Размеры (мм)						Сплав TT9080
	DC	LPR	PL	LF	CHW	SSC	
TCD-151-P+	15.1	8.73	3.20	5.53	0.38	15	●
152-P+	15.2	8.73	3.22	5.51	0.38	15	●
155-P+	15.5	8.73	3.26	5.47	0.38	15	●
159-P+	15.9	8.73	3.31	5.42	0.38	15	●
160-P+	16.0	9.30	3.46	5.84	0.44	16	●
161-P+	16.1	9.30	3.47	5.83	0.44	16	●
163-P+	16.3	9.30	3.50	5.80	0.44	16	●
164-P+	16.4	9.30	3.51	5.79	0.44	16	●
165-P+	16.5	9.30	3.53	5.77	0.44	16	●
167-P+	16.7	9.30	3.55	5.75	0.44	16	●
170-P+	17.0	9.90	3.63	6.27	0.44	17	●
173-P+	17.3	9.90	3.67	6.23	0.44	17	●
175-P+	17.5	9.90	3.70	6.20	0.44	17	●
180-P+	18.0	10.50	3.81	6.69	0.44	18	●
185-P+	18.5	10.50	3.88	6.62	0.44	18	●
190-P+	19.0	11.00	3.98	7.02	0.44	19	●
192-P+	19.2	11.00	4.01	6.99	0.44	19	●
193-P+	19.3	11.00	4.02	6.98	0.44	19	●
194-P+	19.4	11.00	4.03	6.97	0.44	19	●
195-P+	19.5	11.00	4.05	6.95	0.44	19	●
200-P+	20.0	11.60	4.15	7.45	0.44	20	●
205-P+	20.5	11.60	4.22	7.38	0.44	20	●
206-P+	20.6	11.60	4.23	7.37	0.44	20	●
210-P+	21.0	12.18	4.32	7.86	0.44	21	●
215-P+	21.5	12.18	4.39	7.79	0.44	21	●
220-P+	22.0	12.76	4.50	8.26	0.44	22	●
222-P+	22.2	12.76	4.53	8.23	0.44	22	●
225-P+	22.5	12.76	4.57	8.19	0.44	22	●
230-P+	23.0	13.33	4.67	8.66	0.44	23	●
235-P+	23.5	13.33	4.74	8.59	0.44	23	●
240-P+	24.0	13.90	4.84	9.06	0.44	24	●
245-P+	24.5	13.90	4.91	8.99	0.44	24	●
250-P+	25.0	14.50	5.01	9.49	0.44	25	●
255-P+	25.5	14.50	5.08	9.42	0.44	25	●
259-P+	25.9	14.50	5.13	9.37	0.44	25	●



● SSC : Размер кармана

● : Стандартная позиция

Сверлильная головка для отверстия с плоским дном

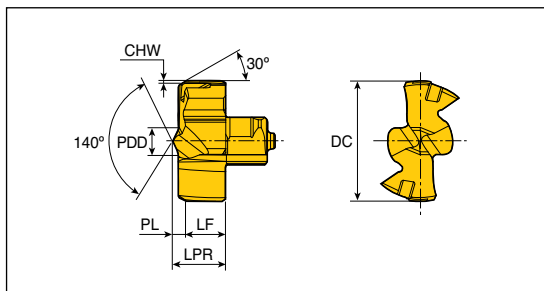

Обозначение	Размеры (мм)							Сплав
	DC	PDD	LPR	PL	LF	CHW	SSC	TT9080
TCD - 080-F	8.0	1.2	4.4	1.09	3.3	0.7	8	●
085-F	8.5	1.2	4.4	1.09	3.3	0.7	8	●
090-F	9.0	1.21	4.6	1.11	3.5	0.7	9	●
095-F	9.5	1.21	4.6	1.11	3.5	0.7	9	●
100-F	10.0	1.27	4.9	1.17	3.7	0.7	10	●
105-F	10.5	1.27	4.9	1.17	3.7	0.7	10	●
110-F	11.0	1.49	5.1	1.25	3.8	0.7	11	●
115-F	11.5	1.49	5.1	1.25	3.8	0.7	11	●
120-F	12.0	1.5	5.4	1.26	4.1	0.7	12	●
125-F	12.5	1.5	5.4	1.26	4.1	0.7	12	●
130-F	13.0	1.64	5.7	1.30	4.4	0.7	13	●
135-F	13.5	1.64	5.7	1.30	4.4	0.7	13	●
140-F	14.0	1.68	6.1	1.31	4.8	0.7	14	●
145-F	14.5	1.68	6.1	1.31	4.8	0.7	14	●
150-F	15.0	1.78	6.6	1.35	5.23	0.7	15	●
155-F	15.5	1.78	6.6	1.35	5.23	0.7	15	●
160-F	16.0	1.89	7.0	1.39	5.6	0.7	16	●
165-F	16.5	1.89	7.0	1.39	5.6	0.7	16	●
170-F	17.0	1.91	7.3	1.40	5.9	0.7	17	●
175-F	17.5	1.91	7.3	1.40	5.9	0.7	17	●
180-F	18.0	1.97	7.6	1.42	6.18	0.7	18	●
185-F	18.5	1.97	7.6	1.42	6.18	0.7	18	●
190-F	19.0	1.96	7.9	1.44	6.5	0.7	19	●
195-F	19.5	1.96	7.9	1.44	6.5	0.7	19	●
200-F	20.0	3.42	9.3	1.77	7.5	0.7	20	●
205-F	20.5	3.42	9.3	1.77	7.5	0.7	20	●
210-F	21.0	3.6	9.7	1.79	7.9	0.7	21	●
215-F	21.5	3.6	9.7	1.79	7.9	0.7	21	●
220-F	22.0	3.8	10.0	1.81	8.2	0.7	22	●
225-F	22.5	3.8	10.0	1.81	8.2	0.7	22	●
230-F	23.0	3.9	10.4	1.83	8.6	0.7	23	●
235-F	23.5	3.9	10.4	1.83	8.6	0.7	23	●
240-F	24.0	4.1	10.9	1.86	9.0	0.7	24	●
245-F	24.5	4.1	10.9	1.86	9.0	0.7	24	●
250-F	25.0	4.3	11.3	1.89	9.4	0.7	25	●



● SSC : Размер кармана

● : Стандартная позиция

Сверлильная головка для отверстия с плоским дном

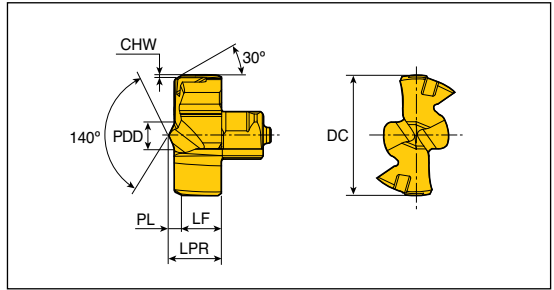

Обозначение	Размеры (мм)							Сплав
	DC	PDD	LPR	PL	LF	CHW	SSC	TT9080
TCD - 254-F	25.4	4.3	11.3	1.89	9.4	0.7	25	•
255-F	25.5	4.3	11.3	1.89	9.4	0.7	25	•



• SSC : Размер кармана

●: Стандартная позиция

Сверлильная головка с двойной ленточкой

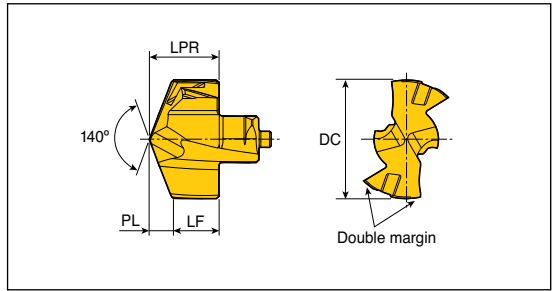

Обозначение	Размеры (мм)					Сплав TT9080
	DC	LPR	PL	LF	SSC	
TCD - 080-P2	8.0	5.4	1.20	4.20	8	●
085-P2	8.5	5.4	1.29	4.11	8	●
090-P2	9.0	5.8	1.35	4.45	9	●
095-P2	9.5	5.8	1.44	4.36	9	●
100-P2	10.0	6.2	1.50	4.70	10	●
105-P2	10.5	6.2	1.59	4.61	10	●
110-P2	11.0	6.6	1.67	4.93	11	●
115-P2	11.5	6.6	1.76	4.84	11	●
120-P2	12.0	7.0	1.82	5.18	12	●
125-P2	12.5	7.0	1.91	5.09	12	●
130-P2	13.0	7.6	1.96	5.64	13	●
135-P2	13.5	7.6	2.05	5.55	13	●
140-P2	14.0	8.15	2.12	6.03	14	●
145-P2	14.5	8.15	2.21	5.94	14	●
150-P2	15.0	8.73	2.27	6.46	15	●
155-P2	15.5	8.73	2.36	6.37	15	●
160-P2	16.0	9.3	2.42	6.88	16	●
165-P2	16.5	9.3	2.51	6.79	16	●
170-P2	17.0	9.9	2.59	7.31	17	●
175-P2	17.5	9.9	2.68	7.22	17	●
180-P2	18.0	10.5	2.73	7.77	18	●
185-P2	18.5	10.5	2.82	7.68	18	●
190-P2	19.0	11.0	2.88	8.12	19	●
195-P2	19.5	11.0	2.97	8.03	19	●



- Другие диаметры доступны по запросу
- SSC : Размер кармана

●: Стандартная позиция

AOMT 060204-C45

Пластина для отверстия под резьбу

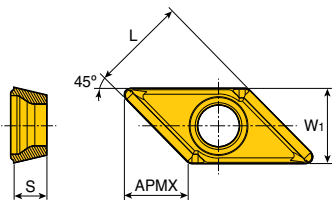

Габарит	Размеры (мм)			
	W1	L	S	APMX
06	4.5	5.66	1.96	4.0

Пластина	Обозначение	С покрытием						Без покрытия	
		TT9080	TT9030	TT8020	TT6030	TT9300	TT7400		
	AOMT 060204-C45	●						K10	



●: Стандартная позиция

CRNG 0802-45CD

Пластина для обработки фаски

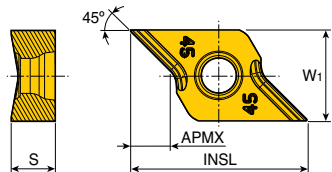

Габарит	Размеры (мм)			
	W1	INSL	S	APMX
08	7.5	14.80	3.65	3.3

Пластина	Обозначение	С покрытием						Без покрытия	
		TT9080	TT9030	TT8020	TT6030	TT9300	TT7400		
	CRNG 0802-45CD	●						K10	



●: Стандартная позиция

TCD...P-CO+

Самоцентрирующаяся сверлильная головка

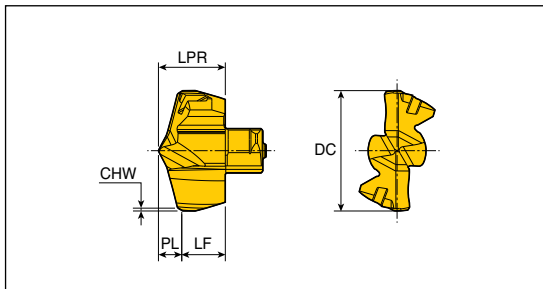

Обозначение	Размеры (мм)						Сплав
	DC	LPR	PL	LF	CHW	SSC	TT9080
TCD-159-P-CO+	15.9	8.73	3.17	5.56	0.38	15	●
169-P-CO+	16.9	9.30	3.34	5.96	0.38	16	●
179-P-CO+	17.9	9.90	3.50	6.40	0.38	17	●
189-P-CO+	18.9	10.50	3.66	6.84	0.38	18	●
199-P-CO+	19.9	11.00	3.82	7.18	0.38	19	●
209-P-CO+	20.9	11.60	3.98	7.62	0.38	20	●
219-P-CO+	21.9	12.18	4.15	8.03	0.38	21	●
229-P-CO+	22.9	12.76	4.31	8.45	0.38	22	●
239-P-CO+	23.9	13.33	4.48	8.85	0.38	23	●
249-P-CO+	24.9	13.90	4.64	9.26	0.38	24	●
259-P-CO+	25.9	14.50	4.81	9.69	0.38	25	●



● SSC : Размер кармана

● : Стандартная позиция

SPGX...DW

Пластина

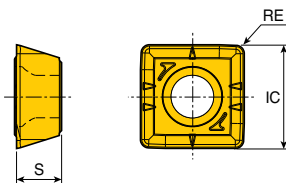

Габарит	Размеры (мм)			
	IC	S	RE	
06	6.07	2.38	0.4	
07	8.02	3.97	0.8	
09	9.91	4.30	0.8	
11	11.62	4.80	0.8	
14	14.41	5.20	1.2	

Пластина	Обозначение	С покрытием						Без покрытия	
		TT9080	TT8020	TT9900	TT9030	TT6080	TT7400	K10	
	SPGX 060204 DW	●							
	07T308 DW	●							
	090408 DW	●							
	110408 DW	●							
	140512 DW	●							



● : Стандартная позиция

Сверлильная головка

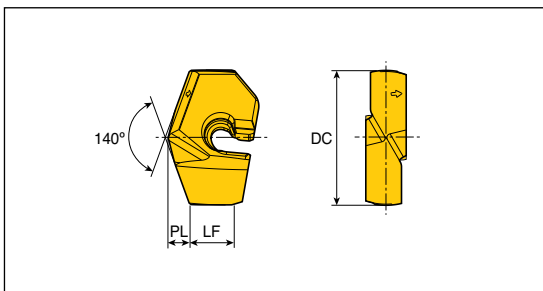

Обозначение	Размеры (мм)				Сплав	
	DC	PL	LF	SSC	ТТ9080	
LCD- 200-P	20.0	3.11	6.54	20	●	
205-P	20.5	3.20	6.45	20	●	
210-P	21.0	3.29	6.36	21	●	
215-P	21.5	3.38	6.27	21	●	
220-P	22.0	3.42	7.12	22	●	
225-P	22.5	3.51	7.03	22	●	
230-P	23.0	3.60	6.94	23	●	
235-P	23.5	3.69	6.85	23	●	
240-P	24.0	3.73	7.03	24	●	
245-P	24.5	3.82	6.94	24	●	
250-P	25.0	3.91	6.85	25	●	
255-P	25.5	4.00	6.76	25	●	
260-P	26.0	4.04	7.51	26	●	
265-P	26.5	4.13	7.42	26	●	
270-P	27.0	4.22	7.33	27	●	
275-P	27.5	4.31	7.24	27	●	
280-P	28.0	4.35	7.39	28	●	
285-P	28.5	4.44	7.30	28	●	
290-P	29.0	4.53	7.21	29	●	
295-P	29.5	4.62	7.12	29	●	
300-P	30.0	4.67	9.47	30	●	
305-P	30.5	4.76	9.38	30	●	
310-P	31.0	4.85	9.29	31	●	
315-P	31.5	4.94	9.20	31	●	
320-P	32.0	4.98	9.55	32	●	
325-P	32.5	5.07	9.46	32	●	
330-P	33.0	5.16	9.37	33	●	
335-P	33.5	5.25	9.28	33	●	
340-P	34.0	5.34	9.19	34	●	
345-P	34.5	5.44	9.10	34	●	
350-P	35.0	5.44	11.12	35	●	
355-P	35.5	5.53	11.03	35	●	
360-P	36.0	5.62	10.94	36	●	
365-P	36.5	5.71	10.85	36	●	
370-P	37.0	5.80	10.76	37	●	



● SSC : Размер кармана

● : Стандартная позиция

LCD...-P

Сверлильная головка

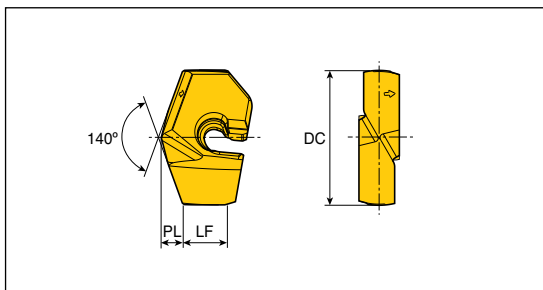

Обозначение	Размеры (мм)				Сплав TT9080
	DC	PL	LF	SSC	
LCD- 375-P	37.5	5.90	10.67	37	●
380-P	38.0	5.91	11.09	38	●
385-P	38.5	6.00	11.00	38	●
390-P	39.0	6.09	10.91	39	●
395-P	39.5	6.18	10.82	39	●
400-P	40.0	6.27	10.73	40	●
405-P	40.5	6.37	10.64	40	●
410-P	41.0	6.46	10.54	40	●



● SSC : Размер кармана

● : Стандартная позиция

LCD...-F

Сверлильная головка для отверстия с плоским дном

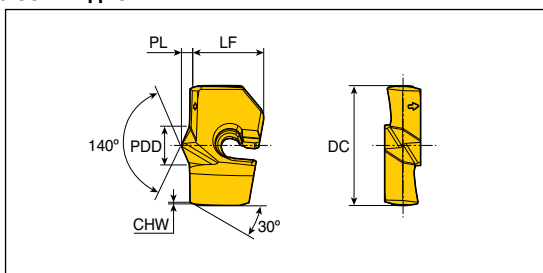

Обозначение	Размеры (мм)					Сплав TT9080	
	DC	PL	LF	CHW	SSC		
LCD - 200-F	20.0	2.11	11.76	0.30	20	6.0	●
205-F	20.5	2.11	11.76	0.30	20	6.0	●
210-F	21.0	2.11	11.76	0.30	20	6.0	●
215-F	21.5	2.11	11.76	0.30	20	6.0	●
220-F	22.0	2.27	12.76	0.30	22	6.6	●
225-F	22.5	2.27	12.76	0.30	22	6.6	●
230-F	23.0	2.27	12.76	0.30	22	6.6	●



● SSC : Размер кармана

● : Стандартная позиция

Сверлильная головка для отверстия с плоским дном

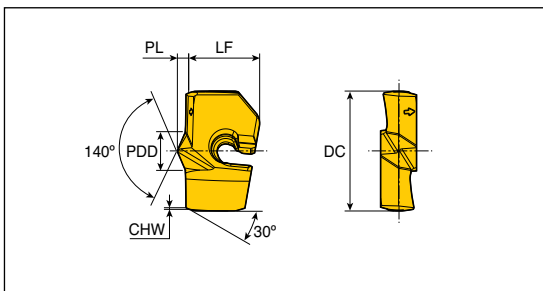

Обозначение	Размеры (мм)						Сплав
	DC	PL	LF	CHW	SSC	PDD	TT9080
LCD - 235-F	23.5	2.27	12.76	0.30	22	6.6	●
240-F	24.0	2.43	13.26	0.30	24	7.2	●
245-F	24.5	2.43	13.26	0.30	24	7.2	●
250-F	25.0	2.43	13.26	0.30	24	7.2	●
255-F	25.5	2.43	13.26	0.30	24	7.2	●
260-F	26.0	2.50	14.90	0.30	26	7.8	●
265-F	26.5	2.50	14.90	0.30	26	7.8	●
270-F	27.0	2.50	14.90	0.30	26	7.8	●
275-F	27.5	2.50	14.90	0.30	26	7.8	●
280-F	28.0	2.66	15.31	0.30	28	8.4	●
285-F	28.5	2.66	15.31	0.30	28	8.4	●
290-F	29.0	2.66	15.31	0.30	28	8.4	●
295-F	29.5	2.66	15.31	0.30	28	8.4	●
300-F	30.0	2.82	17.76	0.30	30	9.0	●
305-F	30.5	2.82	17.76	0.30	30	9.0	●
310-F	31.0	2.82	17.76	0.30	30	9.0	●
315-F	31.5	2.82	17.76	0.30	30	9.0	●
320-F	32.0	2.98	18.31	0.30	32	9.6	●
325-F	32.5	2.98	18.31	0.30	32	9.6	●
330-F	33.0	2.98	18.31	0.30	32	9.6	●
335-F	33.5	2.98	18.31	0.30	32	9.6	●
340-F	34.0	2.98	18.31	0.30	32	9.6	●
345-F	34.5	2.98	18.31	0.30	32	9.6	●
350-F	35.0	3.21	20.30	0.30	35	10.5	●
355-F	35.5	3.21	20.30	0.30	35	10.5	●
360-F	36.0	3.21	20.30	0.30	35	10.5	●
365-F	36.5	3.21	20.30	0.30	35	10.5	●
370-F	37.0	3.21	20.30	0.30	35	10.5	●
375-F	37.5	3.21	20.30	0.30	35	10.5	●
380-F	38.0	3.44	20.90	0.30	38	11.4	●
385-F	38.5	3.44	20.90	0.30	38	11.4	●
390-F	39.0	3.44	20.90	0.30	38	11.4	●
395-F	39.5	3.44	20.90	0.30	38	11.4	●
400-F	40.0	3.44	20.90	0.30	38	11.4	●
405-F	40.5	3.44	20.90	0.30	38	11.4	●
410-F	41.0	3.44	20.90	0.30	38	11.4	●



● SSC : Размер кармана

●: Стандартная позиция

Пластина для инструмента T-CHAMFER

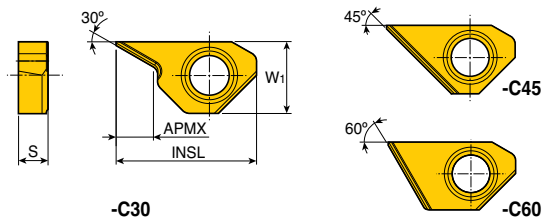

Габарит	Размеры (мм)			
	W1	INSL	S	APMX
06-C30	6.18	12.3	2.8	3.49
09-C30	8.50	16.0	3.3	4.43
06-C45	6.18	12.3	2.8	5.89
09-C45	8.50	16.0	3.3	8.07
06-C60	6.18	12.3	2.8	3.43
09-C60	8.50	16.0	3.3	4.78

Пластина	Обозначение	С покрытием							Без покрытия	
		TT9080	TT9090	TT8020	TT6030	TT9300	TT7400	TT9050		K10
	XCGT 0603-C30							●		
	0903-C30							●		
	XCGT 0603-C45							●		
	0903-C45							●		
	XCGT 0603-C60							●		
	0903-C60							●		

●: Стандартная позиция



D87

Пластина

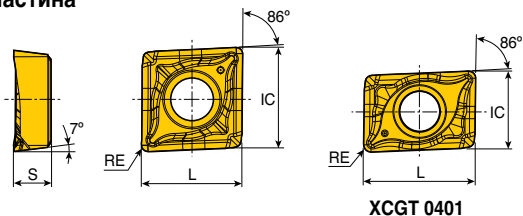

XCGT 0401

Габарит	Размеры (мм)			
	IC	L	S	RE
04	4.4	6.4	1.70	0.4
05	5.6	5.6	2.10	0.4
06	6.4	6.4	2.38	0.4
07	7.5	7.5	3.18	0.4
08	8.4	8.4	3.18	0.4
10	10.5	10.5	3.97	0.4
13	13.4	13.4	4.76	0.4
17	17.5	17.5	5.56	0.8

• Для алюминиевых сплавов

Пластина	Обозначение	Точение		Сверление	С покрытием					Без покрытия		
		ap (мм)	Подача (мм/об)	Подача (мм/об)	TT9080	TT8020	TT9300	TT9030	TT6030	TT7400	K10	
 Правосторонняя (XCGT 0401)	XCGT 040104R TA	0.2-1.8	0.02-0.15	0.02-0.09							•	
	040104L TA	0.2-1.8	0.02-0.15	0.02-0.09							•	
	050204 TA	0.2-2.2	0.03-0.18	0.02-0.11							•	
	060204 TA	0.3-2.5	0.03-0.20	0.03-0.12							•	
	070304 TA	0.4-2.8	0.05-0.22	0.03-0.13							•	
	080304 TA	0.4-3.2	0.06-0.25	0.03-0.13							•	
	10T304 TA	0.5-3.5	0.06-0.30	0.03-0.13							•	
	130404 TA	0.6-4.3	0.08-0.33	0.03-0.13							•	
	170508 TA	0.7-5.3	0.10-0.38	0.03-0.13							•	



• Стандартная позиция

XGMT..R-GV

Пластина

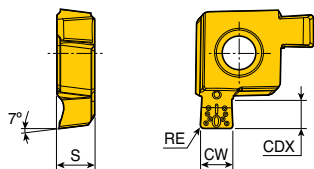

Габарит	Размеры (мм)			
	CW	CDX	S	RE
05	2.0	1.8	2.28	0.2
06	2.0	2.0	2.65	0.2
07	2.5	2.0	3.41	0.2
08	2.5	2.5	3.50	0.2
10	3.0	3.0	4.34	0.3
13	3.5	3.5	5.18	0.3
17	4.0	4.0	6.00	0.4

• Для обработки канавок

Пластина	Обозначение	С покрытием						Без покрытия	
		TT9080	TT8020	TT9300	TT9030	TT6030	TT7400	K10	
	XGMT 05R-200020GV	•	•						
	06R-200020GV	•	•						
	07R-250020GV	•	•						
	08R-250020GV	•	•						
	10R-300030GV	•	•						
	13R-350030GV	•	•						
	17R-400040GV	•	•						



• Доступны только правосторонние канавочные пластины

• Стандартная позиция

Пластина

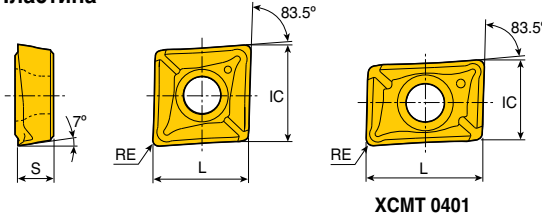

Габарит	Размеры (мм)			
	IC	L	S	RE
04	4.4	6.4	1.70	0.4
05	5.6	5.6	2.10	0.4
06	6.4	6.4	2.38	0.4
07	7.5	7.5	3.18	0.4
08	8.4	8.4	3.18	0.4
10	10.5	10.5	3.97	0.4/0.8
13	13.4	13.4	4.76	0.4/0.8
17	17.4	17.4	5.56	0.8

- Для сверления, растачивания и точения

Пластина	Обозначение	Точение		Сверление Подача (мм/об)	С покрытием					Без покрытия	
		ар (мм)	Подача (мм/об)		ТТ9080	ТТ8020	ТТ9300	ТТ9030	ТТ6030	ТТ7400	K10
 Правосторонняя (XCMT 0401) 	XCMT 040104R TC	0.2-1.8	0.02-0.15	0.02-0.09	●	●	●				
	040104L TC	0.2-1.8	0.02-0.15	0.02-0.09	●	●	●				
	050204 TC	0.2-2.2	0.03-0.18	0.02-0.11	●	●	●				
	060204 TC	0.3-2.5	0.03-0.20	0.03-0.12	●	●	●				
	070304 TC	0.4-2.8	0.05-0.22	0.03-0.13	●	●	●				
	080304 TC	0.4-3.2	0.06-0.25	0.03-0.13	●	●	●				
	10T304 TC	0.5-3.5	0.06-0.30	0.03-0.13	●	●	●				
	10T308 TC	0.5-3.5	0.06-0.30	0.03-0.13	●	●	●				
	130404 TC	0.6-4.3	0.08-0.33	0.03-0.13	●	●	●				
	130408 TC	0.6-4.3	0.08-0.33	0.03-0.13	●	●	●				
170508 TC	0.7-5.3	0.10-0.38	0.03-0.13	●	●	●					

●: Стандартная позиция



NPHT...RG



Пластина для головки TBTA-FB и сверла TRGD

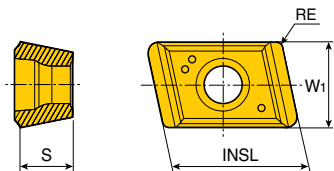

Габарит	Размеры (мм)			
	W ₁	INSL	S	RE
06	6.0	8.0	3.0	0.8
07	7.5	10.0	4.0	0.8
09	9.0	10.0	4.0	0.8
11	11.0	10.0	4.0	0.8
13	13.0	10.0	4.0	0.8

Пластина	Обозначение	Карман			С покрытием						Без покрытия		
		Центральный	Внутренний	Наружный	TT9030	TT8125	TT7100	TT3500	TT6020	TT9300	TT7400	K10	
	NPHT 06003RG			●	●				●				
	07504RG			●	●				●				
	09004RG			●	●				●				
	11004RG			●	●				●				
	13004RG			●	●				●				

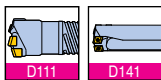

●: Стандартная позиция

NPMT...LG



Пластина для головки TBTA-FB и сверла TRGD

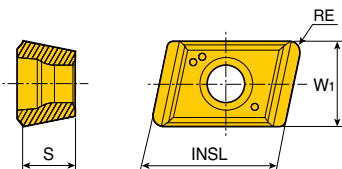

Габарит	Размеры (мм)			
	W ₁	INSL	S	RE
05	5.5	8	3.0	0.8
06	6.5	10	4.0	0.8
08	8.0	10	4.0	0.8
09	9.5	10	4.0	0.8
12	12.5	10	4.0	0.8

Пластина	Обозначение	Карман			С покрытием						Без покрытия		
		Центральный	Внутренний	Наружный	TT9030	TT8125	TT7100	TT3500	TT6020	TT9300	TT7400	K10	
	NPMT 05503LG	●			●	●			●				
	06504LG	●			●	●			●				
	08004LG	●			●	●			●				
	09504LG	●			●	●			●				
	12504LG	●			●	●			●				

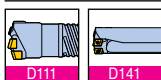

●: Стандартная позиция

Пластина для головки ТВТА-FB и сверла TRGD

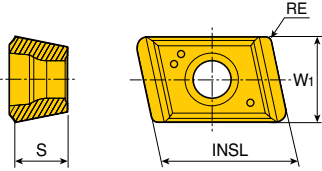

Габарит	Размеры (мм)			
	W1	INSL	S	RE
05	5.5	8	3.0	0.8
06	6.5	10	4.0	0.8
08	8.0	10	4.0	0.8
09	9.5	10	4.0	0.8
12	12.5	10	4.0	0.8

Пластина	Обозначение	Карман			С покрытием						Без покрытия	
		Центральный	Внутренний	Наружный	TT9030	TT8125	TT7100	TT3500	TT6020	TT9300	TT7400	K10
	NPMT 05503RG		•		•	•		•				
	06504RG		•		•	•		•				
	08004RG		•		•	•		•				
	09504RG		•		•	•		•				
	12504RG		•		•	•		•				

•: Стандартная позиция

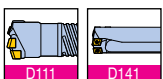

NPMX...RB/RG



Пластина для головки ТВТА...3/5/7/9

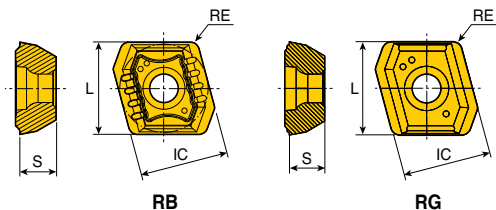

Габарит	Размеры (мм)			
	IC	L	S	RE
08	8.0	8.36	3.18	0.8

Пластина	Обозначение	Карман			С покрытием						Без покрытия		
		Центральный	Внутренний	Наружный	TT9030	TT8125	TT7100	TT3500	TT6020	TT9300	TT7400	K10	
	NPMX 0803RB	●	●	●	●								
	0803RG	●	●	●	●					●			



●: Стандартная позиция

TPMX...RB/RG



Пластина для головки ТВТА...3/5/7/9 и сверла ТВТА-R

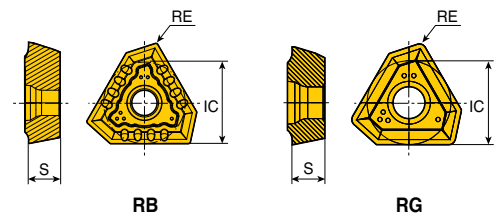

Габарит	Размеры (мм)		
	IC	S	RE
1403RB	8.45	3.5	0.4
1403RG	8.45	3.5	0.8
1704RB	10.30	4.0	0.4
1704RG	10.30	4.0	0.8
2405RB	14.20	5.5	0.4
2405RG	14.20	5.5	1.2
2807RB	17.00	7.5	0.8
2807RG	17.00	7.5	1.6

Пластина	Обозначение	Карман			С покрытием						Без покрытия		
		Центральный	Внутренний	Наружный	TT9030	TT8125	TT7100	TT3500	TT6020	TT9300	TT7400	K10	
	TPMX 1403RB	●	●	●	●	●							
	1403RG	●	●	●	●	●							
	1704RB	●	●	●	●								
	1704RG	●	●	●	●		●	●		●			
	2405RB	●	●	●	●								
	2405RG	●	●	●	●						●		
	2807RB	●	●	●	●								
	2807RG	●	●	●	●						●		



●: Стандартная позиция

Пластина для головки ТВТА-TR и сверла TRGD



Рис.1



Рис.2

Габарит	Размеры (мм)			
	IC	PL	S	RE
07	7.69	2.0	2.3	0.4
08	8.32	2.2	2.8	0.5
09	8.55	3.0	3.0	0.5
10	9.23	3.2	3.3	0.5
11	10.40	3.4	3.8	0.5
12	11.59	3.7	4.3	0.5

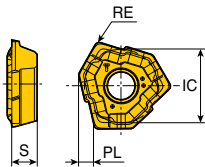
Пластина	Обозначение	Рис.	С покрытием						Без покрытия	
			TT9090	TT8125	TT7100	TT3500	TT6020	TT9300	TT7400	K10
	TOGT 070304 RS	1	●							
	070304 GF	1	●							
	080305 RS	1	●							
	080305 GF	1	●							
	090305 RS	2	●							
	090305 GF	2	●							
	100305 RS	2	●							
	100305 GF	2	●							
	110405 RS	2	●							
	110405 GF	2	●							
	120405 RS	2	●							
120405 GF	2	●								

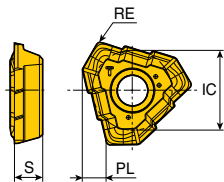

D122



D139

- RS: Для общего применения
- GF: Для жаропрочных материалов

•●: Стандартная позиция

Пластина для головки ТВТА-R

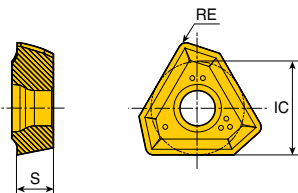

Габарит	Размеры (мм)			
	IC	S	RE	
14	8.45	3.5	0.8	
17	10.30	4.0	0.8	
24	14.20	5.5	1.2	

Пластина	Обозначение	Карман			С покрытием						Без покрытия		
		Центральный	Внутренний	Наружный	TT9030	TT8125	TT7100	TT3500	TT6020	TT9300	TT7400	K10	
	TPMX 1403LG			●	●								
	1704LG			●	●								
	2405LG			●	●								



●: Стандартная позиция

XPMT...-45

Пластина для головки ТВТА-R

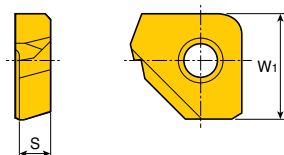

Габарит	Размеры (мм)			
	W1	S		
16	9.5	2.70		

Пластина	Обозначение	Карман			С покрытием						Без покрытия		
		Центральный	Внутренний	Наружный	TT9030	TT8125	TT7100	TT3500	TT6020	TT9300	TT7400	K10	
	XPMT 16002-45			●	●								



●: Стандартная позиция

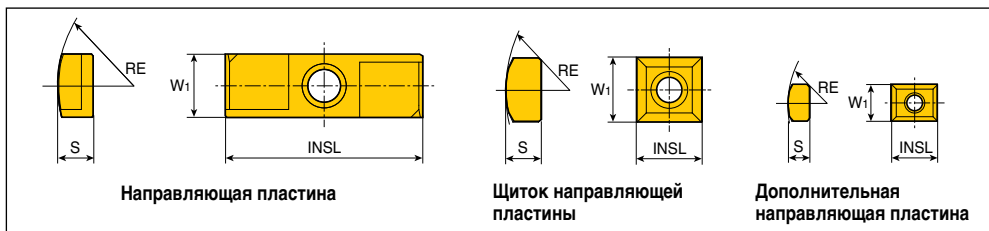

Обозначение		Размеры (мм)				Винт
		W1	S	INSL	RE	
Направляющая пластина	PAD - G008CD-SA-FB	8	4.5	25	15.5	CSTB3S
	G008CD-SB-FB	8	4.5	25	15.5	CSTB3S
	GC10-SA	10	6.0	35	20.0	CSTB4S
	GC10-SB	10	6.0	35	20.0	CSTB4S
	GC14-SB	14	7.5	40	25.0	CSTA5S
	GC18-SB	18	9.0	40	30.0	LS1206S
Щиток направляющей пластины	PAD - P08	8	4.5	8	17.5	CSTB3S
	P10	10	6.0	10	20.0	CSTB4S
	P14	14	7.5	14	25.0	CSTA5S
	P18	18	9.0	18	30.0	LS1206S
	PAD - S08	8	4.5	10	17.5	CSTB3S
Дополнительная направляющая пластина	S10	10	5.0	10	29.0	CSTB3S
	S14	14	7.0	20	45.0	CCSTA5S



+ Направляющие пластины для головок ТВТА 3.../5.../7.../9...

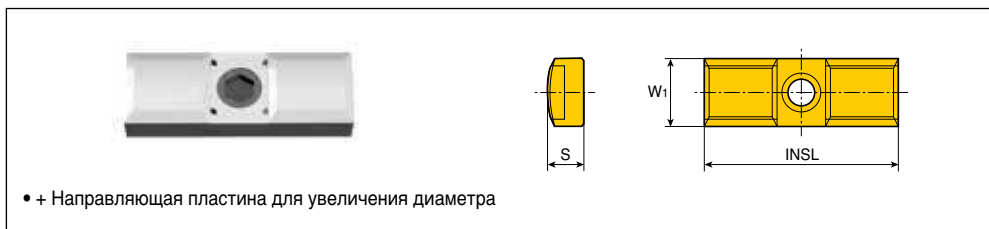

Обозначение										
DC	DC+1мм	S	DC+2мм	S	DC+3мм	S	DC+4мм	S	DC+5мм	S
PAD-GC08	PAD-GC08+1	5.0	PAD-GC08+2	5.5	PAD-GC08+3	6.0	-	-	-	-
PAD-GC10	PAD-GC10+1	6.5	PAD-GC10+2	7.0	PAD-GC10+3	7.5	PAD-GC10+4	8.0	-	-
PAD-GC14	PAD-GC14+1	8.0	PAD-GC14+2	8.5	PAD-GC14+3	9.0	PAD-GC14+4	9.5	PAD-GC14+5	10.0
PAD-GC18	PAD-GC18+1	9.5	PAD-GC18+2	10	PAD-GC18+3	10.5	PAD-GC18+4	11.0	PAD-GC18+5	11.5



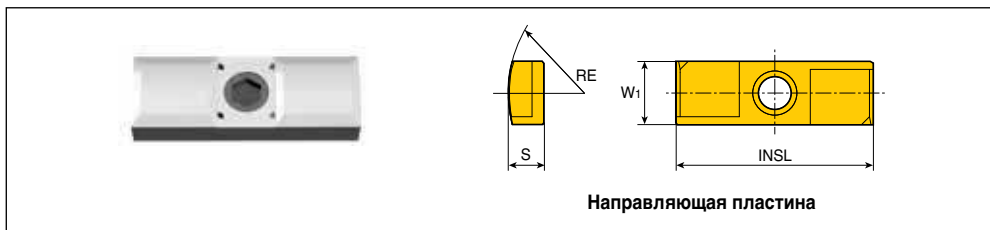

Обозначение		Размеры (мм)				Винт
		W1	S	INSL	RE	
Направляющая пластина	PAD - G006CD-SA	6	3.0	20	12.0	CSTB2.2S
	G006CD-SB	6	3.0	20	12.0	CSTB2.2S
	G007CD-SA	7	3.5	20	12.0	CSTB3.0S
	G007CD-SB	7	3.5	20	12.0	CSTB3.0S
	G008CD-SA-FB	8	4.5	25	15.5	CSTB3.5S
	G008CD-SB-FB	8	4.5	25	15.5	CSTB3.5S
	G010CD-SA	10	4.5	30	20.0	CSTB3.5S
	G010CD-SB	10	4.5	30	20.0	CSTB3.5S
	G012CD-SA	12	5.5	35	25.0	CSTB3.5S
	G012CD-SB	12	5.5	35	25.0	CSTB3.5S



Направляющие пластины для головок ТВТА-TR и сверла TRGD

Твердосплавные направляющие пластины

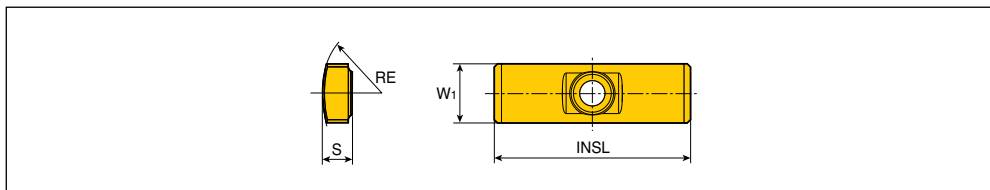

Обозначение		Размеры (мм)				Винт
		W1	S	INSL	RE	
Направляющая пластина	PAD - G005-060-SB	5	2.5	18	6.0	SR34-508
	G005-075-CD-SA	5	2.5	18	7.5	SR34-508
	G005-075-CD-SB	5	2.5	18	7.5	SR34-508
	G006CD-SA	6	3	20	12.0	CSTB2.2S*
	G006CD-SB	6	3	20	12.0	CSTB2.2S*
	G006-075CD-SA	6	3	20	7.5	CSTB2.2S*
	G006-075CD-SB	6	3	20	7.5	CSTB2.2S*
	G006-085CD-SA	6	3	20	8.5	CSTB2.2S*
	G006-085CD-SB	6	3	20	8.5	CSTB2.2S*
	G006-100CD-SA	6	3	20	10.0	CSTB2.2S*
	G006-100CD-SB	6	3	20	10.0	CSTB2.2S*



- Направляющие пластины в сплаве "SB" - первый выбор для общего применения. Направляющие пластины в сплаве "SA" применяются только если используется СОЖ на масляной основе.

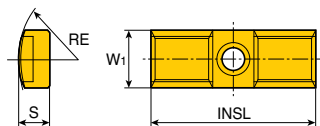

Направляющая пластина

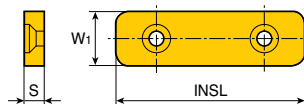

Резиновая направляющая пластина

Обозначение		Размеры (мм)				Винт
		W1	S	INSL	RE	
Направляющая пластина	PAD - GC08-120	8	4.4	25	17.5	CSTB3S
	GC08-140	8	3.5	25	17.5	CSTB3S
	G008CD-SA-FB	8	4.5	25	15.5	CSTB3S
	G008CD-SB-FB	8	4.5	25	15.5	CSTB3S
	GC10-SA	10	6.0	35	20.0	CSTB4S
	GC10-SB	10	6.0	35	20.0	CSTB4S
	GC14-SB	14	7.5	40	25.0	CSTA5S
	GC18-SB	18	9.0	40	30.0	LS1206S
Резиновая направляющая пластина	PAD - R10	10	4.0	40	-	LS0902.5-6
	R12	12	5.0	45	-	LS0903-8
	R15	15	5.8	50	-	LS0904-10
	R20	20	7.5	70	-	LS0905-12
	R30	30	12.5	80	-	LS0906-15
	R35	35	15.5	100	-	LS0906-15



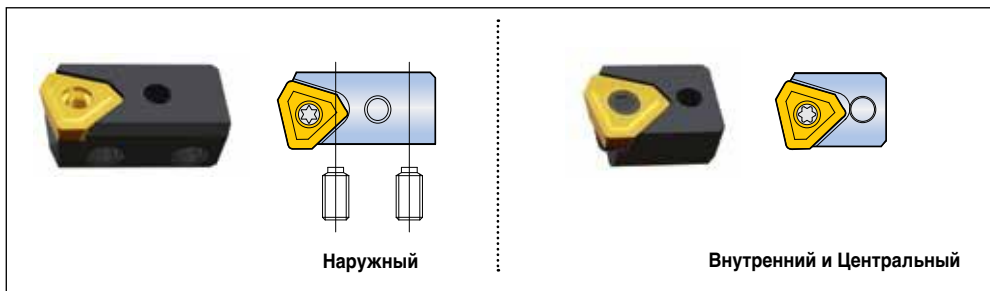

Обозначение		Регулировочный винт	Ключ	Стопорный винт	Ключ	Пластина
Наружный	PERC 05R	AS0003-5	H1.5	LS1803RH	H2	NPMX0803..
	402-04	AS0004-8	H2	LS1803.5RH	H2.5	TPMX1403..
	402-32	AS0005-10	H2.5	LS1805RH	H3	TPMX1704..
	402-43	AS0005-15	H2.5	L1806RH	H4	TPMX2405..
	402-63	AS0006-15	H3	L1806RH	H4	TPMX2807..
Внутренний и Центральный	GENC 05R	-	-	CSTB3	T9	NPMX0803..
	402-04	-	-	CSTB3.5	T15	TPMX1403..
	402-32	-	-	CSTA5	T15	TPMX1704..
	402-43	-	-	LS1206	H3	TPMX2405..
	402-63	-	-	LS1206	H3	TPMX2807..



+ Картриджи для головок ТВТА 3.../5.../7.../9



Обозначение					
DC	DC+1мм	DC+2мм	DC+3мм	DC+4мм	DC+5мм
PERC 05R	PERC 05R+1	PERC 05R+2	-	-	-
PERC 402-04	PERC 402-04+1	PERC 402-04+2	PERC 402-04+3	-	-
PERC 402-32	PERC 402-32+1	PERC 402-32+2	PERC 402-32+3	PERC 402-32+4	-
PERC 402-43	PERC 402-43+1	PERC 402-43+2	PERC 402-43+3	PERC 402-43+4	PERC 402-43+5
PERC 402-63	PERC 402-63+1	PERC 402-63+2	PERC 402-63+3	PERC 402-63+4	PERC 402-63+5



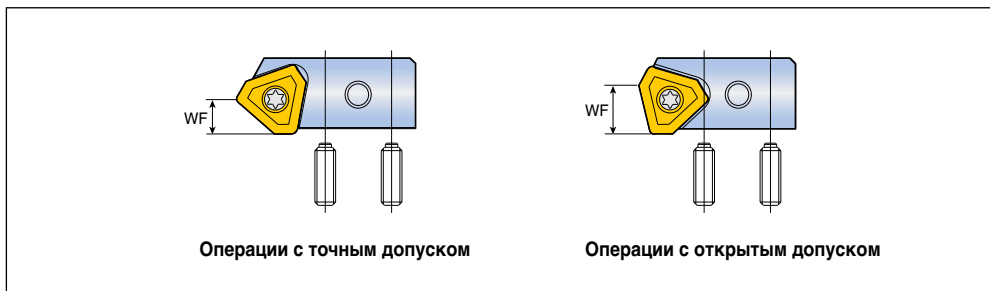

Обозначение		WF (мм)	Регулировочный винт	Ключ	Стопорный винт	Ключ	Пластина
Для точного допуска	PERC P04R	5	AS0004-8	H2	LS1803.5RH	H2.5	TPMX1403 LG
	P32R	6	AS0005-10	H2.5	LS1805RH	H3	TPMX1704 LG
	P43R	8	AS0005-15	H2.5	LS1806RH	H4	TPMX2405 LG
Для открытого допуска	PERC 402-04	8	AS0004-8	H2	LS1803.5RH	H2.5	TPMX1403 RG
	402-32	9	AS0005-10	H2.5	LS1805RH	H3	TPMX1704 RG
	402-43	13	AS0005-15	H2.5	LS1806RH	H4	TPMX2405 RG



• Картриджи PERC-P и PERC 402-□ □ взаимозаменяемы

Направляющие пластины для головок TNDH-TP

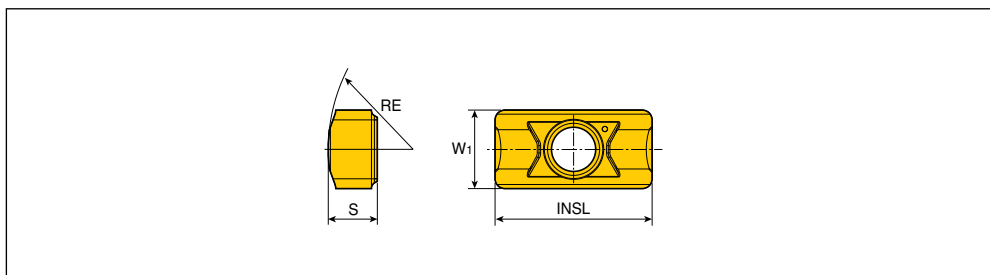

Обозначение	Размеры (мм)				Винт	Сплав TT9030
	W1	S	INSL	RE		
PAD-G04-08	4	2.5	8	9	TS 20043I/HG-P	•



• Направляющую необходимо заказывать отдельно

• Стандартная позиция

Рекомендуемые условия резания

Режимы обработки для TOP-DRILL 2,3,4xD

ISO	Материал	Состояние	Предел прочности (Н/мм ²)	Твердость по Бринеллю	Материал №	Скорость резания Vc (м/мин)	
P	Нелегированная сталь, литье, легкообрабатываемая сталь	<0.25%C	Отожженная	420	125	1	220-350
		>=0.25%C	Отожженная	650	190	2	180-280
		<0.55%C	Закалённая и отпущенная	850	250	3	140-240
		>=0.55%C	Отожженная	750	220	4	140-240
			Закалённая и отпущенная	1000	300	5	140-240
	Низколегированная сталь и литье (менее 5% легирующих добавок)		Отожженная	600	200	6	140-240
		Закалённая и отпущенная		930	275	7	100-180
				1000	300	8	100-180
				1200	350	9	100-180
	Высоколегированная сталь, литье и инструментальная сталь	Отожженная	680	200	10	140-200	
Закалённая и отпущенная		1100	325	11	100-160		
M	Нержавеющая сталь и литье	Ферритная/Мартенситная	680	200	12	150-250	
		Мартенситная	820	240	13	150-250	
		Аустенитная	600	180	14	150-250	
K	Серый чугун (GG)	Ферритный		160	15	160-260	
		Перлитный		250	16	160-260	
	Чугун с шаровидным графитом (GGG)	Ферритный		180	17	160-260	
		Перлитный		260	18	160-260	
	Ковкий чугун	Ферритный		130	19	120-220	
Перлитный			230	20	120-220		
N	Деформируемые алюминиевые сплавы	Неструктурированные		60	21	200-350	
		Структурированные		100	22	200-350	
	Алюминий - литье, легированный сплав	<=12% Si	Неструктурированные		75	23	200-350
			Структурированные		90	24	200-350
		>12% Si	Жаропрочные сплавы		130	25	200-350
	Сплавы меди	>1% Pb	Легкообрабатываемые		110	26	150-250
			Латунь		90	27	150-250
			Электролитная медь		100	28	150-250
	Неметаллические материалы	Реактопласты, волокниты				29	150-250
		Твердая резина				30	150-250
S	Жаропрочные сплавы	На основе железа	Отожженная		200	31	30-60
			Структурированные		280	32	30-60
		На основе никеля или кобальта	Отожженная		250	33	30-60
			Структурированные		350	34	30-60
	Титан, титановые сплавы	Литье		320	35	30-60	
				Rm 400		36	50-80
H	Закаленная сталь	Закалка			55HRC	38	30-60
		Закалка			60HRC	39	30-60
	Отбеленный чугун	Литье			400	40	30-60
	Чугун с шаровидным графитом	Закалка			55HRC	41	30-60

• Подробную информацию по группам материалов см. в Техническом Руководстве, "Таблица соответствия материалов"

■ Сталь
 ■ Нержавеющая сталь
 ■ Чугун
 ■ Цветные металлы
 ■ Жаропрочные сплавы
 ■ Закаленная сталь

Рекомендуемые условия резания



Режимы обработки для TOP-DRILL 2,3,4xD

Подача (мм/об) и диаметр сверла Длина сверла 2,3,4xD								
SOMT 04 Ø12 - Ø13.5	SOMT 05 Ø14 - Ø16	SOMT 06 Ø17 - Ø19	SOMT 07 Ø20 - Ø22	SOMT 08 Ø23 - Ø26	SOMT 09 Ø27 - Ø31	SOMT 11 Ø32 - Ø36	SOMT 13 Ø37 - Ø43	SOMT 15 Ø44 - Ø50
0.04-0.06	0.04-0.06	0.04-0.06	0.04-0.08	0.04-0.08	0.06-0.10	0.06-0.10	0.08-0.12	0.08-0.12
0.06-0.10	0.06-0.10	0.06-0.10	0.06-0.12	0.06-0.12	0.08-0.14	0.08-0.14	0.08-0.16	0.10-0.16
0.08-0.12	0.08-0.12	0.08-0.12	0.08-0.16	0.08-0.16	0.10-0.16	0.10-0.16	0.10-0.18	0.10-0.18
0.08-0.12	0.08-0.12	0.08-0.12	0.08-0.16	0.08-0.16	0.10-0.16	0.10-0.16	0.10-0.18	0.10-0.18
0.08-0.12	0.08-0.12	0.08-0.12	0.08-0.16	0.08-0.16	0.10-0.16	0.10-0.16	0.10-0.18	0.10-0.18
0.06-0.16	0.06-0.16	0.06-0.16	0.08-0.20	0.08-0.20	0.08-0.20	0.10-0.22	0.10-0.22	0.10-0.24
0.06-0.16	0.06-0.16	0.06-0.16	0.08-0.20	0.08-0.20	0.08-0.20	0.08-0.22	0.10-0.22	0.10-0.22
0.06-0.16	0.06-0.16	0.06-0.16	0.08-0.20	0.08-0.20	0.08-0.20	0.08-0.22	0.10-0.22	0.10-0.22
0.06-0.16	0.06-0.16	0.06-0.16	0.08-0.20	0.08-0.20	0.08-0.20	0.08-0.22	0.10-0.22	0.10-0.22
0.06-0.12	0.06-0.12	0.06-0.12	0.08-0.16	0.08-0.16	0.08-0.18	0.08-0.20	0.10-0.20	0.10-0.20
0.06-0.12	0.06-0.12	0.06-0.12	0.08-0.16	0.08-0.16	0.08-0.18	0.08-0.20	0.10-0.20	0.10-0.20
0.06-0.12	0.06-0.12	0.06-0.12	0.06-0.16	0.06-0.16	0.08-0.18	0.08-0.20	0.10-0.20	0.10-0.20
0.06-0.12	0.06-0.12	0.06-0.12	0.06-0.16	0.06-0.16	0.08-0.18	0.08-0.20	0.10-0.20	0.10-0.20
0.06-0.12	0.06-0.12	0.06-0.12	0.06-0.16	0.06-0.16	0.08-0.18	0.08-0.20	0.10-0.20	0.10-0.20
0.08-0.18	0.08-0.18	0.08-0.18	0.10-0.20	0.10-0.20	0.10-0.20	0.10-0.20	0.10-0.22	0.10-0.22
0.08-0.18	0.08-0.18	0.08-0.18	0.10-0.20	0.10-0.20	0.10-0.20	0.10-0.20	0.10-0.22	0.10-0.22
0.08-0.18	0.08-0.18	0.08-0.18	0.10-0.20	0.10-0.20	0.10-0.20	0.10-0.20	0.10-0.22	0.10-0.22
0.08-0.18	0.08-0.18	0.08-0.18	0.10-0.20	0.10-0.20	0.10-0.20	0.10-0.20	0.10-0.22	0.10-0.22
0.08-0.14	0.08-0.14	0.08-0.14	0.10-0.16	0.10-0.16	0.10-0.16	0.10-0.18	0.10-0.18	0.10-0.18
0.08-0.14	0.08-0.14	0.08-0.14	0.10-0.16	0.10-0.16	0.10-0.16	0.10-0.18	0.10-0.18	0.10-0.18
0.06-0.15	0.06-0.15	0.06-0.15	0.08-0.16	0.08-0.16	0.08-0.18	0.08-0.18	0.10-0.18	0.10-0.18
0.06-0.15	0.06-0.15	0.06-0.15	0.08-0.16	0.08-0.16	0.08-0.18	0.08-0.18	0.10-0.18	0.10-0.18
0.06-0.15	0.06-0.15	0.06-0.15	0.08-0.16	0.08-0.16	0.08-0.18	0.08-0.18	0.10-0.18	0.10-0.18
0.06-0.15	0.06-0.15	0.06-0.15	0.08-0.16	0.08-0.16	0.08-0.18	0.08-0.18	0.10-0.18	0.10-0.18
0.06-0.15	0.06-0.15	0.06-0.15	0.08-0.16	0.08-0.16	0.08-0.16	0.08-0.17	0.10-0.18	0.10-0.18
0.06-0.15	0.06-0.15	0.06-0.15	0.08-0.16	0.08-0.16	0.08-0.16	0.08-0.17	0.10-0.18	0.10-0.18
0.06-0.15	0.06-0.15	0.06-0.15	0.08-0.16	0.08-0.16	0.08-0.16	0.08-0.17	0.10-0.18	0.10-0.18
0.06-0.15	0.06-0.15	0.06-0.15	0.08-0.16	0.08-0.16	0.10-0.17	0.10-0.17	0.10-0.18	0.10-0.18
0.06-0.15	0.06-0.15	0.06-0.15	0.08-0.16	0.08-0.16	0.10-0.17	0.10-0.17	0.10-0.18	0.10-0.18
0.05-0.08	0.05-0.08	0.05-0.08	0.05-0.09	0.05-0.09	0.06-0.10	0.06-0.10	0.06-0.12	0.06-0.12
0.05-0.08	0.05-0.08	0.05-0.08	0.05-0.09	0.05-0.09	0.06-0.10	0.06-0.10	0.06-0.12	0.06-0.12
0.05-0.08	0.05-0.08	0.05-0.08	0.05-0.09	0.05-0.09	0.06-0.10	0.06-0.10	0.06-0.12	0.06-0.12
0.05-0.08	0.05-0.08	0.05-0.08	0.05-0.09	0.05-0.09	0.06-0.10	0.06-0.10	0.06-0.12	0.06-0.12
0.06-0.09	0.06-0.09	0.06-0.09	0.06-0.10	0.06-0.10	0.06-0.10	0.06-0.10	0.06-0.10	0.06-0.10
0.06-0.09	0.06-0.09	0.06-0.09	0.06-0.10	0.06-0.10	0.06-0.10	0.06-0.10	0.06-0.10	0.06-0.10
0.05-0.09	0.05-0.09	0.05-0.09	0.05-0.10	0.05-0.10	0.05-0.10	0.05-0.10	0.05-0.10	0.05-0.10
0.05-0.09	0.05-0.09	0.05-0.09	0.05-0.10	0.05-0.10	0.05-0.10	0.05-0.10	0.05-0.10	0.05-0.10
0.05-0.09	0.05-0.09	0.05-0.09	0.05-0.10	0.05-0.10	0.05-0.10	0.05-0.10	0.05-0.10	0.05-0.10
0.05-0.09	0.05-0.09	0.05-0.09	0.05-0.10	0.05-0.10	0.05-0.10	0.05-0.10	0.05-0.10	0.05-0.10

Режимы обработки для TOP-DRILL 5xD

ISO	Материал	Состояние	Предел прочности (Н/мм ²)	Твердость по Бринеллю	Материал №	Скорость резания V _c (м/мин)	
P	Нелегированная сталь, литье, легкообрабатываемая сталь	<0.25%C	Отожженная	420	125	1	220-350
		≥0.25%C	Отожженная	650	190	2	180-280
		<0.55%C	Закалённая и отпущенная	850	250	3	140-240
		≥0.55%C	Отожженная	750	220	4	140-240
			Закалённая и отпущенная	1000	300	5	140-240
	Низколегированная сталь и литье (менее 5% легирующих добавок)	Отожженная		600	200	6	140-240
				930	275	7	100-180
		Закалённая и отпущенная		1000	300	8	100-180
				1200	350	9	100-180
	Высоколегированная сталь, литье и инструментальная сталь	Отожженная		680	200	10	140-200
Закалённая и отпущенная			1100	325	11	100-160	
M	Нержавеющая сталь и литье	Ферритная/Мартенситная		680	200	12	150-250
		Мартенситная		820	240	13	150-250
		Аустенитная		600	180	14	150-250
K	Серый чугун (GG)	Ферритный			160	15	160-260
		Перлитный			250	16	160-260
	Чугун с шаровидным графитом (GGG)	Ферритный			180	17	160-260
		Перлитный			260	18	160-260
	Ковкий чугун	Ферритный			130	19	120-220
Перлитный				230	20	120-220	
N	Деформируемые алюминиевые сплавы	Неструктурированные		60	21	200-350	
		Структурированные		100	22	200-350	
	Алюминий - литье, легированный сплав	<=12% Si	Неструктурированные		75	23	200-350
			Структурированные		90	24	200-350
		>12% Si	Жаропрочные сплавы		130	25	200-350
	Сплавы меди	>1% Pb	Легкообрабатываемые		110	26	150-250
			Латунь		90	27	150-250
			Электролитная медь		100	28	150-250
	Неметаллические материалы	Реактопласты, волокниты				29	150-250
		Твердая резина				30	150-250
S	Жаропрочные сплавы	На основе железа	Отожженная		200	31	30-60
			Структурированные		280	32	30-60
		На основе никеля или кобальта	Отожженная		250	33	30-60
			Структурированные		350	34	30-60
	Титан, титановые сплавы	Литье		320	35	30-60	
			Rm 400		36	50-80	
H	Закаленная сталь	Закалка			55HRC	38	30-60
		Закалка			60HRC	39	30-60
	Отбеленный чугун	Литье			400	40	30-60
	Чугун с шаровидным графитом	Закалка			55HRC	41	30-60

• Подробную информацию по группам материалов см. в Техническом Руководстве, "Таблица соответствия материалов"

■ Сталь
 ■ Нержавеющая сталь
 ■ Чугун
 ■ Цветные металлы
 ■ Жаропрочные сплавы
 ■ Закаленная сталь

Рекомендуемые условия резания



Режимы обработки для TOP-DRILL 5xD

Подача (мм/об) и диаметр сверла Длина сверла 5xD								
SOMT 04 Ø12 - Ø13.5	SOMT 05 Ø14 - Ø16	SOMT 06 Ø17 - Ø19	SOMT 07 Ø20 - Ø22	SOMT 08 Ø23 - Ø26	SOMT 09 Ø27 - Ø31	SOMT 11 Ø32 - Ø36	SOMT 13 Ø37 - Ø43	SOMT 15 Ø44 - Ø50
0.04-0.05	0.04-0.05	0.04-0.05	0.04-0.05	0.04-0.06	0.06-0.08	0.06-0.08	0.08-0.10	0.08-0.10
0.06-0.08	0.06-0.08	0.06-0.08	0.06-0.10	0.06-0.10	0.08-0.12	0.08-0.12	0.08-0.14	0.10-0.14
0.06-0.10	0.06-0.10	0.06-0.10	0.06-0.12	0.06-0.12	0.10-0.15	0.10-0.15	0.10-0.17	0.10-0.17
0.06-0.10	0.06-0.10	0.06-0.10	0.06-0.12	0.06-0.12	0.10-0.15	0.10-0.15	0.10-0.17	0.10-0.17
0.06-0.10	0.06-0.10	0.06-0.10	0.06-0.12	0.06-0.12	0.10-0.15	0.10-0.15	0.10-0.17	0.10-0.17
0.06-0.12	0.06-0.12	0.06-0.12	0.08-0.16	0.08-0.16	0.08-0.18	0.10-0.20	0.10-0.20	0.10-0.22
0.06-0.12	0.06-0.12	0.06-0.12	0.08-0.16	0.08-0.16	0.08-0.18	0.10-0.20	0.10-0.20	0.10-0.22
0.06-0.12	0.06-0.12	0.06-0.12	0.08-0.16	0.08-0.16	0.08-0.18	0.10-0.20	0.10-0.20	0.10-0.22
0.06-0.12	0.06-0.12	0.06-0.12	0.08-0.16	0.08-0.16	0.08-0.18	0.10-0.20	0.10-0.20	0.10-0.22
0.06-0.10	0.06-0.10	0.06-0.10	0.08-0.12	0.08-0.12	0.08-0.16	0.08-0.18	0.10-0.18	0.10-0.20
0.06-0.10	0.06-0.10	0.06-0.10	0.08-0.12	0.08-0.12	0.08-0.16	0.08-0.18	0.10-0.18	0.10-0.20
0.06-0.10	0.06-0.10	0.06-0.10	0.06-0.12	0.06-0.12	0.08-0.16	0.08-0.18	0.10-0.18	0.10-0.20
0.06-0.10	0.06-0.10	0.06-0.10	0.06-0.12	0.06-0.12	0.08-0.16	0.08-0.18	0.10-0.18	0.10-0.20
0.08-0.14	0.08-0.14	0.08-0.14	0.08-0.16	0.08-0.16	0.10-0.18	0.10-0.18	0.10-0.20	0.10-0.20
0.08-0.14	0.08-0.14	0.08-0.14	0.08-0.16	0.08-0.16	0.10-0.18	0.10-0.18	0.10-0.20	0.10-0.20
0.08-0.14	0.08-0.14	0.08-0.14	0.08-0.16	0.08-0.16	0.10-0.18	0.10-0.18	0.10-0.20	0.10-0.20
0.08-0.14	0.08-0.14	0.08-0.14	0.08-0.16	0.08-0.16	0.10-0.18	0.10-0.18	0.10-0.20	0.10-0.20
0.08-0.12	0.08-0.12	0.08-0.14	0.08-0.16	0.08-0.16	0.10-0.16	0.10-0.16	0.10-0.16	0.10-0.16
0.08-0.12	0.08-0.12	0.08-0.14	0.08-0.16	0.08-0.16	0.10-0.16	0.10-0.16	0.10-0.16	0.10-0.16
0.06-0.15	0.06-0.15	0.06-0.15	0.08-0.16	0.08-0.16	0.08-0.16	0.08-0.16	0.10-0.17	0.10-0.17
0.06-0.15	0.06-0.15	0.06-0.15	0.08-0.16	0.08-0.16	0.08-0.16	0.08-0.16	0.10-0.17	0.10-0.17
0.06-0.15	0.06-0.15	0.06-0.15	0.08-0.16	0.08-0.16	0.08-0.16	0.08-0.16	0.10-0.17	0.10-0.17
0.06-0.15	0.06-0.15	0.06-0.15	0.08-0.16	0.08-0.16	0.08-0.16	0.08-0.16	0.10-0.17	0.10-0.17
0.06-0.15	0.06-0.15	0.06-0.15	0.08-0.16	0.08-0.16	0.08-0.16	0.08-0.16	0.10-0.17	0.10-0.17
0.06-0.15	0.06-0.15	0.06-0.15	0.08-0.16	0.08-0.16	0.08-0.16	0.08-0.16	0.10-0.17	0.10-0.17
0.06-0.15	0.06-0.15	0.06-0.15	0.08-0.16	0.08-0.16	0.08-0.16	0.08-0.16	0.10-0.17	0.10-0.17
0.06-0.15	0.06-0.15	0.06-0.15	0.08-0.16	0.08-0.16	0.08-0.16	0.08-0.16	0.10-0.17	0.10-0.17
0.05-0.07	0.05-0.07	0.05-0.08	0.05-0.08	0.05-0.08	0.06-0.09	0.06-0.09	0.06-0.10	0.06-0.10
0.05-0.07	0.05-0.07	0.05-0.08	0.05-0.08	0.05-0.08	0.06-0.09	0.06-0.09	0.06-0.10	0.06-0.10
0.05-0.07	0.05-0.07	0.05-0.08	0.05-0.08	0.05-0.08	0.06-0.09	0.06-0.09	0.06-0.10	0.06-0.10
0.05-0.07	0.05-0.07	0.05-0.08	0.05-0.08	0.05-0.08	0.06-0.09	0.06-0.09	0.06-0.10	0.06-0.10
0.05-0.08	0.05-0.08	0.05-0.08	0.06-0.09	0.06-0.09	0.06-0.10	0.06-0.10	0.06-0.10	0.06-0.10
0.05-0.08	0.05-0.08	0.05-0.08	0.06-0.09	0.06-0.09	0.06-0.10	0.06-0.10	0.06-0.10	0.06-0.10
0.05-0.08	0.05-0.08	0.05-0.08	0.05-0.09	0.05-0.09	0.05-0.10	0.05-0.10	0.05-0.10	0.05-0.10
0.05-0.08	0.05-0.08	0.05-0.08	0.05-0.09	0.05-0.09	0.05-0.10	0.05-0.10	0.05-0.10	0.05-0.10
0.05-0.08	0.05-0.08	0.05-0.08	0.05-0.09	0.05-0.09	0.05-0.10	0.05-0.10	0.05-0.10	0.05-0.10

Рекомендуемые условия резания



Режимы обработки для T-DRILL 2,3,4xD

ISO	Материал	Состояние	Предел прочности (Н/мм ²)	Твердость по Бринеллю	Материал №	Скорость резания V _c (м/мин)			
P	Нелегированная сталь, литье, легкообрабатываемая сталь	<0.25%C	Отожженная	420	125	1	250-350		
		>=0.25%C	Отожженная	650	190	2	180-250		
		<0.55%C	Закаленная и отпущенная	850	250	3	160-220		
		>=0.55%C	Отожженная	750	220	4	160-220		
			Закаленная и отпущенная	1000	300	5	160-220		
	Низколегированная сталь и литье (менее 5% легирующих добавок)	Отожженная		600	200	6	150-220		
				930	275	7	120-160		
		Закаленная и отпущенная		1000	300	8	120-160		
				1200	350	9	120-160		
	Высоколегированная сталь, литье и инструментальная сталь	Отожженная		680	200	10	140-180		
Закаленная и отпущенная			1100	325	11	130-180			
M	Нержавеющая сталь и литье	Ферритная/Мартенситная		680	200	12	170-240		
		Мартенситная		820	240	13	170-240		
		Аустенитная		600	180	14	170-240		
K	Серый чугун (GG)	Ферритный			160	15	180-250		
		Перлитный			250	16	180-250		
	Чугун с шаровидным графитом (GGG)	Ферритный			180	17	180-250		
		Перлитный			260	18	180-250		
	Ковкий чугун	Ферритный			130	19	130-200		
Перлитный				230	20	130-200			
N	Деформируемые алюминиевые сплавы	Неструктурированные			60	21	330-380		
		Структурированные			100	22	330-380		
	Алюминий - литье, легированный сплав	<=12% Si	Неструктурированные			75	23	330-380	
			Структурированные			90	24	330-380	
		>12% Si	Жаропрочные сплавы			130	25	330-380	
	Сплавы меди	>1% Pb	Легкообрабатываемые			110	26	150-230	
			Латунь			90	27	150-230	
			Электролитная медь			100	28	150-230	
	Неметаллические материалы	Реактопласты, волокниты					29	150-230	
		Твердая резина					30	150-230	
S	Жаропрочные сплавы	На основе железа	Отожженная			200	31	30-60	
			Структурированные			280	32	30-60	
		На основе никеля или кобальта	Отожженная			250	33	30-60	
			Структурированные			350	34	30-60	
	Титан, титановые сплавы	Литье			320	35	30-60		
				Rm 400			36	30-60	
H	Закаленная сталь	Закалка				55HRC	38	30-60	
		Закалка				60HRC	39	30-60	
	Отбеленный чугун	Литье				400	40	30-60	
	Чугун с шаровидным графитом	Закалка					55HRC	41	30-60

• Подробную информацию по группам материалов см. в Техническом Руководстве, "Таблица соответствия материалов"

■ Сталь
 ■ Нержавеющая сталь
 ■ Чугун
 ■ Цветные металлы
 ■ Жаропрочные сплавы
 ■ Закаленная сталь

Рекомендуемые условия резания



Режимы обработки для T-DRILL 2,3,4xD

Подача (мм/об) и диаметр сверла Длина сверла 2,3,4xD					
SPMG 05 Ø12.5 - Ø15	SPMG 06 Ø16 - Ø21	SPMG 07 Ø22 - Ø27	SPMG 09 Ø28 - Ø33	SPMG 11 Ø34 - Ø41	SPMG 14 Ø42 - Ø50
0.04-0.06	0.04-0.06	0.04-0.08	0.04-0.08	0.06-0.10	0.06-0.12
0.05-0.08	0.06-0.10	0.06-0.12	0.07-0.13	0.08-0.15	0.08-0.16
0.06-0.12	0.08-0.15	0.10-0.18	0.12-0.22	0.12-0.24	0.13-0.25
0.06-0.12	0.08-0.15	0.10-0.18	0.12-0.22	0.12-0.24	0.13-0.25
0.06-0.12	0.08-0.14	0.10-0.18	0.12-0.20	0.12-0.20	0.13-0.20
0.06-0.15	0.06-0.15	0.08-0.18	0.08-0.18	0.08-0.18	0.08-0.18
0.06-0.15	0.06-0.15	0.08-0.18	0.08-0.18	0.08-0.18	0.08-0.18
0.06-0.15	0.06-0.15	0.08-0.18	0.08-0.18	0.08-0.18	0.08-0.18
0.06-0.10	0.06-0.10	0.08-0.12	0.08-0.14	0.08-0.14	0.08-0.14
0.06-0.10	0.08-0.12	0.10-0.15	0.12-0.15	0.12-0.18	0.13-0.18
0.05-0.10	0.06-0.12	0.08-0.15	0.09-0.16	0.10-0.17	0.11-0.18
0.05-0.10	0.06-0.12	0.08-0.15	0.09-0.16	0.10-0.17	0.11-0.18
0.05-0.10	0.06-0.12	0.08-0.15	0.09-0.16	0.10-0.17	0.11-0.18
0.06-0.12	0.08-0.16	0.12-0.20	0.15-0.25	0.16-0.28	0.18-0.30
0.06-0.12	0.08-0.16	0.12-0.20	0.15-0.25	0.16-0.28	0.18-0.30
0.06-0.12	0.08-0.16	0.12-0.20	0.15-0.25	0.16-0.28	0.18-0.30
0.06-0.12	0.08-0.16	0.12-0.20	0.15-0.25	0.16-0.28	0.18-0.30
0.06-0.10	0.08-0.15	0.10-0.18	0.12-0.20	0.15-0.23	0.16-0.25
0.06-0.10	0.08-0.15	0.10-0.18	0.12-0.20	0.15-0.23	0.16-0.25
0.06-0.14	0.08-0.15	0.10-0.20	0.12-0.22	0.14-0.23	0.15-0.26
0.06-0.14	0.08-0.15	0.10-0.20	0.12-0.22	0.14-0.23	0.15-0.26
0.06-0.14	0.08-0.15	0.10-0.20	0.12-0.22	0.14-0.23	0.15-0.26
0.06-0.14	0.08-0.15	0.10-0.20	0.12-0.22	0.14-0.23	0.15-0.26
0.06-0.13	0.06-0.13	0.08-0.15	0.08-0.15	0.08-0.15	0.08-0.15
0.06-0.13	0.06-0.13	0.08-0.15	0.08-0.15	0.08-0.15	0.08-0.15
0.06-0.13	0.06-0.13	0.08-0.15	0.08-0.15	0.08-0.15	0.08-0.15
0.06-0.13	0.06-0.13	0.08-0.15	0.08-0.15	0.08-0.15	0.08-0.15
0.05-0.08	0.05-0.08	0.05-0.09	0.05-0.09	0.05-0.09	0.05-0.09
0.05-0.08	0.05-0.08	0.05-0.09	0.05-0.09	0.05-0.09	0.05-0.09
0.05-0.08	0.05-0.08	0.05-0.09	0.05-0.09	0.05-0.09	0.05-0.09
0.05-0.08	0.05-0.08	0.05-0.09	0.05-0.09	0.05-0.09	0.05-0.09
0.05-0.10	0.06-0.14	0.08-0.18	0.10-0.22	0.14-0.23	0.15-0.24
0.05-0.10	0.06-0.14	0.08-0.18	0.10-0.22	0.14-0.23	0.15-0.24
0.05-0.09	0.05-0.09	0.05-0.10	0.05-0.10	0.05-0.10	0.05-0.10
0.05-0.09	0.05-0.09	0.05-0.10	0.05-0.10	0.05-0.10	0.05-0.10
0.05-0.09	0.05-0.09	0.05-0.10	0.05-0.10	0.05-0.10	0.05-0.10
0.05-0.09	0.05-0.09	0.05-0.10	0.05-0.10	0.05-0.10	0.05-0.10

Рекомендуемые условия резания



Режимы обработки для T-DRILL 5xD

ISO	Материал	Состояние	Предел прочности (Н/мм ²)	Твердость по Бринеллю	Материал №	Скорость резания V _c (м/мин)			
P	Нелегированная сталь, литье, легкообрабатываемая сталь	<0.25%C	Отожженная	420	125	1	250-350		
		>=0.25%C	Отожженная	650	190	2	180-250		
		<0.55%C	Закалённая и отпущенная	850	250	3	160-220		
		>=0.55%C	Отожженная	750	220	4	160-220		
			Закалённая и отпущенная	1000	300	5	160-220		
	Низколегированная сталь и литье (менее 5% легирующих добавок)	Отожженная		600	200	6	150-220		
				930	275	7	120-160		
		Закалённая и отпущенная		1000	300	8	120-160		
				1200	350	9	120-160		
	Высоколегированная сталь, литье и инструментальная сталь	Отожженная		680	200	10	140-180		
Закалённая и отпущенная			1100	325	11	130-180			
M	Нержавеющая сталь и литье	Ферритная/Мартенситная		680	200	12	170-240		
		Мартенситная		820	240	13	170-240		
		Аустенитная		600	180	14	170-240		
K	Серый чугун (GG)	Ферритный			160	15	180-250		
		Перлитный			250	16	180-250		
	Чугун с шаровидным графитом (GGG)	Ферритный			180	17	180-250		
		Перлитный			260	18	180-250		
	Ковкий чугун	Ферритный			130	19	130-200		
Перлитный				230	20	130-200			
N	Деформируемые алюминиевые сплавы	Неструктурированные			60	21	330-380		
		Структурированные			100	22	330-380		
	Алюминий - литье, легированный сплав	<=12% Si	Неструктурированные			75	23	330-380	
			Структурированные			90	24	330-380	
		>12% Si	Жаропрочные сплавы			130	25	330-380	
	Сплавы меди	>1% Pb	Легкообрабатываемые			110	26	150-230	
			Латунь			90	27	150-230	
			Электролитная медь			100	28	150-230	
	Неметаллические материалы	Реактопласты, волокниты					29	150-230	
		Твердая резина					30	150-230	
S	Жаропрочные сплавы	На основе железа	Отожженная			200	31	30-60	
			Структурированные			280	32	30-60	
		На основе никеля или кобальта	Отожженная			250	33	30-60	
			Структурированные			350	34	30-60	
	Титан, титановые сплавы	Литье				320	35	30-60	
				Rm 400			36	30-60	
H	Закаленная сталь	Закалка				55HRC	38	30-60	
		Закалка				60HRC	39	30-60	
	Отбеленный чугун	Литье				400	40	30-60	
	Чугун с шаровидным графитом	Закалка					55HRC	41	30-60

• Подробную информацию по группам материалов см. в Техническом Руководстве, "Таблица соответствия материалов"

■ Сталь
 ■ Нержавеющая сталь
 ■ Чугун
 ■ Цветные металлы
 ■ Жаропрочные сплавы
 ■ Закаленная сталь

Рекомендуемые условия резания



Режимы обработки для T-DRILL 5xD

Подача (мм/об) и диаметр сверла Длина сверла 5xD					
SPMG 05 Ø12.5 - Ø15	SPMG 06 Ø16 - Ø21	SPMG 07 Ø22 - Ø27	SPMG 09 Ø28 - Ø33	SPMG 11 Ø34 - Ø41	SPMG 14 Ø42 - Ø50
0.04-0.05	0.04-0.05	0.04-0.06	0.04-0.07	0.06-0.08	0.06-0.10
0.06-0.08	0.06-0.08	0.06-0.10	0.07-0.12	0.08-0.13	0.08-0.14
0.06-0.10	0.08-0.13	0.10-0.16	0.12-0.20	0.12-0.22	0.13-0.23
0.06-0.10	0.08-0.13	0.10-0.16	0.12-0.20	0.12-0.22	0.13-0.23
0.06-0.10	0.08-0.12	0.10-0.16	0.12-0.18	0.12-0.18	0.13-0.18
0.06-0.12	0.06-0.13	0.08-0.16	0.08-0.16	0.08-0.17	0.08-0.17
0.06-0.12	0.06-0.13	0.08-0.16	0.08-0.16	0.08-0.17	0.08-0.17
0.06-0.12	0.06-0.13	0.08-0.16	0.08-0.16	0.08-0.17	0.08-0.17
0.06-0.08	0.06-0.08	0.08-0.10	0.08-0.12	0.08-0.12	0.08-0.12
0.06-0.09	0.08-0.10	0.10-0.13	0.12-0.13	0.12-0.15	0.12-0.16
0.05-0.09	0.06-0.10	0.08-0.13	0.09-0.15	0.10-0.15	0.10-0.17
0.05-0.09	0.06-0.10	0.08-0.13	0.09-0.15	0.10-0.15	0.10-0.17
0.05-0.09	0.06-0.10	0.08-0.13	0.09-0.15	0.10-0.15	0.10-0.17
0.06-0.10	0.08-0.15	0.12-0.18	0.15-0.22	0.16-0.25	0.18-0.28
0.06-0.10	0.08-0.15	0.12-0.18	0.15-0.22	0.16-0.25	0.18-0.28
0.06-0.10	0.08-0.15	0.12-0.18	0.15-0.22	0.16-0.25	0.18-0.28
0.06-0.10	0.08-0.15	0.12-0.18	0.15-0.22	0.16-0.25	0.18-0.28
0.06-0.08	0.08-0.12	0.10-0.16	0.12-0.18	0.15-0.22	0.16-0.23
0.06-0.08	0.08-0.12	0.10-0.16	0.12-0.18	0.15-0.22	0.16-0.23
0.06-0.12	0.08-0.15	0.10-0.13	0.12-0.18	0.14-0.20	0.14-0.24
0.06-0.12	0.08-0.15	0.10-0.13	0.12-0.18	0.14-0.20	0.14-0.24
0.06-0.12	0.08-0.15	0.10-0.13	0.12-0.18	0.14-0.20	0.14-0.24
0.06-0.12	0.08-0.15	0.10-0.13	0.12-0.18	0.14-0.20	0.14-0.24
0.06-0.12	0.08-0.15	0.10-0.13	0.12-0.18	0.14-0.20	0.14-0.24
0.06-0.12	0.06-0.12	0.08-0.13	0.08-0.13	0.08-0.14	0.08-0.14
0.06-0.12	0.06-0.12	0.08-0.13	0.08-0.13	0.08-0.14	0.08-0.14
0.06-0.12	0.06-0.12	0.08-0.13	0.08-0.13	0.08-0.14	0.08-0.14
0.06-0.12	0.06-0.12	0.08-0.13	0.08-0.13	0.08-0.14	0.08-0.14
0.05-0.07	0.05-0.07	0.05-0.08	0.05-0.08	0.05-0.08	0.05-0.08
0.05-0.07	0.05-0.07	0.05-0.08	0.05-0.08	0.05-0.08	0.05-0.08
0.05-0.07	0.05-0.07	0.05-0.08	0.05-0.08	0.05-0.08	0.05-0.08
0.05-0.07	0.05-0.07	0.05-0.08	0.05-0.08	0.05-0.08	0.05-0.08
0.05-0.07	0.05-0.07	0.05-0.08	0.05-0.08	0.05-0.08	0.05-0.08
0.05-0.09	0.08-0.13	0.08-0.17	0.10-0.20	0.14-0.22	0.14-0.24
0.05-0.09	0.08-0.13	0.08-0.17	0.10-0.20	0.14-0.22	0.14-0.24
0.05-0.08	0.05-0.08	0.05-0.09	0.05-0.09	0.05-0.09	0.05-0.09
0.05-0.08	0.05-0.08	0.05-0.09	0.05-0.09	0.05-0.09	0.05-0.09
0.05-0.08	0.05-0.08	0.05-0.09	0.05-0.09	0.05-0.09	0.05-0.09
0.05-0.08	0.05-0.08	0.05-0.09	0.05-0.09	0.05-0.09	0.05-0.09

Режимы обработки для DRILL-SPEED

ISO	Материал	Состояние	Пример материала (JIS)	Предел прочности (Н/мм ²)	Твердость по Бринеллю	Материал №	
P	Нелегированная сталь, литье, легкообрабатываемая сталь	<0.25%C	Отожженная	SS41/S10C	420	125	1
		>=0.25%C	Отожженная	S25C	650	190	2
		<0.55%C	Закалённая и отпущенная	S45C	850	250	3
		>=0.55%C	Отожженная	S55C	750	220	4
			Закалённая и отпущенная	SK3	1000	300	5
	Низколегированная сталь и литье (менее 5% легирующих добавок)	Отожженная		SCM4	600	200	6
				SKS3	930	275	7
		Закалённая и отпущенная			1000	300	8
						1200	350
	Высоколегированная сталь, литье и инструментальная сталь	Отожженная	SKD61	680	200	10	
Закалённая и отпущенная		SKH/HSS	1100	325	11		
M	Нержавеющая сталь и литье	Ферритная/Мартенситная		680	200	12	
		Мартенситная		820	240	13	
		Аустенитная		600	180	14	
K	Серый чугун (GG)	Ферритный	FC		160	15	
		Перлитный			250	16	
	Чугун с шаровидным графитом (GGG)	Ферритный	FCD		180	17	
		Перлитный			260	18	
	Ковкий чугун	Ферритный	FCMP/AC4A		130	19	
Перлитный				230	20		
N	Деформируемые алюминиевые сплавы	Неструктурированные			60	21	
		Структурированные			100	22	
	Алюминий - литье, легированный сплав	<=12% Si	Неструктурированные			75	23
			Структурированные			90	24
		>12% Si	Жаропрочные сплавы			130	25
	Сплавы меди	>1% Pb	Легкообрабатываемые			110	26
			Латунь			90	27
			Электролитная медь			100	28
	Неметаллические материалы	Реактопласты, волокниты					29
		Твердая резина					30
S	Жаропрочные сплавы	На основе железа	Отожженная			200	31
			Структурированные			280	32
		На основе никеля или кобальта	Отожженная			250	33
			Структурированные			350	34
			Литье			320	35
	Титан, титановые сплавы				Rm 400		36
Альфа и бета сплавы структурированные				Rm 1050		37	
H	Закаленная сталь	Закалка			55HRC	38	
		Закалка			60HRC	39	
	Отбеленный чугун	Литье			400	40	
	Чугун с шаровидным графитом	Закалка			55HRC	41	

• Подробную информацию по группам материалов см. в Техническом Руководстве, "Таблица соответствия материалов"

■ Сталь
 ■ Нержавеющая сталь
 ■ Чугун
 ■ Цветные металлы
 ■ Жаропрочные сплавы
 ■ Закаленная сталь

Рекомендуемые условия резания



Режимы обработки для DRILL-SFEED

Скорость резания Vc(м/мин)	Подача (мм/об) и диаметр сверла		
	Ø16 - Ø20.9		
80-140	0.35-0.55		
80-130	0.35-0.55		
80-120	0.35-0.55		
70-110	0.35-0.55		
50-90	0.35-0.55		
80-120	0.30-0.50		
70-110	0.30-0.50		
50-90	0.30-0.50		
40-70	0.30-0.50		
50-90	0.30-0.45		
40-80	0.30-0.45		
90-160	0.45-0.65		
80-140	0.45-0.65		
90-180	0.40-0.60		
80-140	0.40-0.60		
90-160	0.40-0.60		
80-140	0.40-0.60		

Рекомендуемые условия резания

Режимы обработки для DRILL-RUSH

ISO	Материал	Состояние	Предел прочности (Н/мм ²)	Твердость по Бринеллю	Материал №	Скорость резания Vc (м/мин)	
P	Нелегированная сталь, литье, легкообрабатываемая сталь	<0.25%C	Отожженная	420	125	1	80-140
		>=0.25%C	Отожженная	650	190	2	80-130
		<0.55%C	Закалённая и отпущенная	850	250	3	80-120
		>=0.55%C	Отожженная	750	220	4	70-110
			Закалённая и отпущенная	1000	300	5	50-90
	Низколегированная сталь и литье (менее 5% легирующих добавок)	Отожженная		600	200	6	70-120
				930	275	7	70-110
		Закалённая и отпущенная		1000	300	8	50-90
				1200	350	9	40-70
	Высоколегированная сталь, литье и инструментальная сталь	Отожженная		680	200	10	50-90
Закалённая и отпущенная			1100	325	11	40-80	
M	Нержавеющая сталь и литье	Ферритная/Мартенситная		680	200	12	40-70
		Мартенситная		820	240	13	40-70
		Аустенитная		600	180	14	30-70
K	Серый чугун (GG)	Ферритный			160	15	90-160
		Перлитный			250	16	80-140
	Чугун с шаровидным графитом (GGG)	Ферритный			180	17	90-180
		Перлитный			260	18	80-140
	Ковкий чугун	Ферритный			130	19	90-160
Перлитный				230	20	80-140	
N	Деформируемые алюминиевые сплавы	Неструктурированные		60	21	90-220	
		Структурированные		100	22	90-220	
	Алюминий - литье, легированный сплав	<=12% Si	Неструктурированные		75	23	90-220
			Структурированные		90	24	90-220
		>12% Si	Жаропрочные сплавы		130	25	80-160
	Сплавы меди	>1% Pb	Легкообрабатываемые		110	26	90-220
			Латунь		90	27	90-220
			Электролитная медь		100	28	90-220
	Неметаллические материалы	Реактопласты, волокниты				29	
		Твердая резина				30	
S	Жаропрочные сплавы	На основе железа	Отожженная		200	31	30-60
			Структурированные		280	32	20-50
		На основе никеля или кобальта	Отожженная		250	33	20-50
			Структурированные		350	34	20-50
	Титан, титановые сплавы	Литье			320	35	20-50
				Rm 400		36	20-50
H	Закаленная сталь	Закалка			55HRC	38	20-50
		Закалка			60HRC	39	20-50
	Отбеленный чугун	Литье			400	40	
	Чугун с шаровидным графитом	Закалка			55HRC	41	

• Подробную информацию по группам материалов см. в Техническом Руководстве, "Таблица соответствия материалов"

■ Сталь
 ■ Нержавеющая сталь
 ■ Чугун
 ■ Цветные металлы
 ■ Жаропрочные сплавы
 ■ Закаленная сталь

Режимы обработки для MODU-R-DRILL

ISO	Материал	Состояние	Предел прочности (Н/мм ²)	Твердость по Бринеллю	Материал №	Скорость резания Vc(м/мин)	
P	Нелегированная сталь, литье, легкообрабатываемая сталь	<0.25%C	Отожженная	420	125	1	120-200
		>=0.25%C	Отожженная	650	190	2	120-200
		<0.55%C	Закалённая и отпущенная	850	250	3	130-190
		>=0.55%C	Отожженная	750	220	4	130-190
			Закалённая и отпущенная	1000	300	5	130-190
	Низколегированная сталь и литье (менее 5% легирующих добавок)	Закалённая и отпущенная	Отожженная	600	200	6	100-200
				930	275	7	100-200
				1000	300	8	100-200
				1200	350	9	100-200
	Высоколегированная сталь, литье и инструментальная сталь	Отожженная	680	200	10	100-160	
Закалённая и отпущенная		1100	325	11	100-160		
M	Нержавеющая сталь и литье	Ферритная/Мартенситная	680	200	12	80-140	
		Мартенситная	820	240	13	80-140	
		Аустенитная	600	180	14	80-140	
K	Серый чугун (GG)	Ферритный		160	15	100-250	
		Перлитный		250	16	100-250	
	Чугун с шаровидным графитом (GGG)	Ферритный		180	17	100-250	
		Перлитный		260	18	100-250	
	Ковкий чугун	Ферритный		130	19	100-250	
Перлитный			230	20	100-250		
N	Деформируемые алюминиевые сплавы	Неструктурированные		60	21	160-260	
		Структурированные		100	22	160-260	
	Алюминий - литье, легированный сплав	<=12% Si	Неструктурированные		75	23	160-260
			Структурированные		90	24	160-260
		>12% Si	Жаропрочные сплавы		130	25	160-260
	Сплавы меди	>1% Pb	Легкообрабатываемые		110	26	160-260
			Латунь		90	27	160-260
			Электролитная медь		100	28	160-260
	Неметаллические материалы	Реактопласты, волокниты				29	
		Твердая резина				30	
S	Жаропрочные сплавы	На основе железа	Отожженная		200	31	30-60
			Структурированные		280	32	30-80
		На основе никеля или кобальта	Отожженная		250	33	30-80
			Структурированные		350	34	30-80
	Титан, титановые сплавы	Литье		320	35	30-80	
				Rm 400		36	30-80
H	Закаленная сталь	Закалка			55HRC	38	20-50
		Закалка			60HRC	39	20-50
	Отбеленный чугун	Литье		400	40		
	Чугун с шаровидным графитом	Закалка			55HRC	41	

Рекомендуемые условия резания

Режимы обработки для MODU-R-DRILL

Подача (мм/об) и диаметр сверла					
SPGX 06 Ø26 - Ø28	SPGX 07 Ø29 - Ø32	SPGX 09 Ø33 - Ø36	SPGX 11 Ø37 - Ø43	SPGX 11 Ø44 - Ø45	SPGX 14 Ø46 - Ø50
0.20-0.35	0.25-0.35	0.2-0.4	0.25-0.4	0.28-0.45	0.28-0.45
0.20-0.35	0.25-0.35	0.2-0.4	0.25-0.4	0.28-0.45	0.28-0.45
0.20-0.35	0.25-0.35	0.2-0.4	0.25-0.4	0.28-0.45	0.28-0.45
0.20-0.35	0.25-0.35	0.2-0.4	0.25-0.4	0.28-0.45	0.28-0.45
0.20-0.35	0.25-0.35	0.2-0.4	0.25-0.4	0.28-0.45	0.28-0.45
0.20-0.33	0.25-0.33	0.25-0.36	0.25-0.36	0.25-0.40	0.25-0.40
0.20-0.33	0.25-0.33	0.25-0.36	0.25-0.36	0.25-0.40	0.25-0.40
0.20-0.33	0.25-0.33	0.25-0.36	0.25-0.36	0.25-0.40	0.25-0.40
0.20-0.33	0.25-0.33	0.25-0.36	0.25-0.36	0.25-0.40	0.25-0.40
0.20-0.33	0.25-0.33	0.25-0.36	0.25-0.36	0.25-0.40	0.25-0.40
0.20-0.33	0.25-0.33	0.25-0.36	0.25-0.36	0.25-0.40	0.25-0.40
0.12-0.24	0.15-0.24	0.16-0.25	0.18-0.28	0.18-0.30	0.18-0.30
0.12-0.24	0.15-0.24	0.16-0.25	0.18-0.28	0.18-0.30	0.18-0.30
0.12-0.24	0.15-0.24	0.16-0.25	0.18-0.28	0.18-0.30	0.18-0.30
0.25-0.45	0.25-0.45	0.3-0.5	0.3-0.5	0.35-0.55	0.35-0.55
0.25-0.45	0.25-0.45	0.3-0.5	0.3-0.5	0.35-0.55	0.35-0.55
0.25-0.45	0.25-0.45	0.3-0.5	0.3-0.5	0.35-0.55	0.35-0.55
0.25-0.45	0.25-0.45	0.3-0.5	0.3-0.5	0.35-0.55	0.35-0.55
0.25-0.45	0.25-0.45	0.3-0.5	0.3-0.5	0.35-0.55	0.35-0.55
0.25-0.45	0.25-0.45	0.3-0.5	0.3-0.5	0.35-0.55	0.35-0.55
0.3-0.5	0.3-0.5	0.35-0.55	0.35-0.55	0.4-0.6	0.4-0.6
0.3-0.5	0.3-0.5	0.35-0.55	0.35-0.55	0.4-0.6	0.4-0.6
0.3-0.5	0.3-0.5	0.35-0.55	0.35-0.55	0.4-0.6	0.4-0.6
0.3-0.5	0.3-0.5	0.35-0.55	0.35-0.55	0.4-0.6	0.4-0.6
0.3-0.5	0.3-0.5	0.35-0.55	0.35-0.55	0.4-0.6	0.4-0.6
0.3-0.5	0.3-0.5	0.35-0.55	0.35-0.55	0.4-0.6	0.4-0.6
0.3-0.5	0.3-0.5	0.35-0.55	0.35-0.55	0.4-0.6	0.4-0.6
0.3-0.5	0.3-0.5	0.35-0.55	0.35-0.55	0.4-0.6	0.4-0.6
0.1-0.16	0.10-0.18	0.15-0.20	0.15-0.22	0.16-0.24	0.16-0.24
0.1-0.16	0.10-0.18	0.15-0.20	0.15-0.22	0.16-0.24	0.16-0.24
0.1-0.16	0.10-0.18	0.15-0.20	0.15-0.22	0.16-0.24	0.16-0.24
0.1-0.16	0.10-0.18	0.15-0.20	0.15-0.22	0.16-0.24	0.16-0.24
0.1-0.16	0.10-0.18	0.15-0.20	0.15-0.22	0.16-0.24	0.16-0.24
0.1-0.16	0.10-0.18	0.15-0.20	0.15-0.22	0.16-0.24	0.16-0.24
0.1-0.16	0.10-0.18	0.15-0.20	0.15-0.22	0.16-0.24	0.16-0.24
0.1-0.16	0.12-0.18	0.14-0.20	0.14-0.20	0.16-0.22	0.16-0.22
0.1-0.16	0.12-0.18	0.14-0.20	0.14-0.20	0.16-0.22	0.16-0.22

Режимы обработки для SPADE-RUSH

ISO	Материал	Состояние	Предел прочности (Н/мм ²)	Твердость по Бринеллю	Материал №	Скорость резания V _c (м/мин)	
P	Нелегированная сталь, литье, легкообрабатываемая сталь	<0.25%C	Отожженная	420	125	1	80-140
		>=0.25%C	Отожженная	650	190	2	80-130
		<0.55%C	Закалённая и отпущенная	850	250	3	80-120
		>=0.55%C	Отожженная	750	220	4	70-110
			Закалённая и отпущенная	1000	300	5	50-90
	Низколегированная сталь и литье (менее 5% легирующих добавок)	Закалённая и отпущенная	Отожженная	600	200	6	80-120
				930	275	7	70-110
				1000	300	8	50-90
				1200	350	9	40-70
	Высоколегированная сталь, литье и инструментальная сталь	Отожженная	680	200	10	50-90	
Закалённая и отпущенная		1100	325	11	40-80		
M	Нержавеющая сталь и литье	Ферритная/Мартенситная	680	200	12	40-70	
		Мартенситная	820	240	13	40-70	
		Аустенитная	600	180	14	30-70	
K	Серый чугун (GG)	Ферритный		160	15	90-180	
		Перлитный		250	16	80-140	
	Чугун с шаровидным графитом (GGG)	Ферритный		180	17	90-165	
		Перлитный		260	18	80-140	
	Ковкий чугун	Ферритный		130	19	90-160	
Перлитный			230	20	80-140		
N	Деформируемые алюминиевые сплавы	Неструктурированные		60	21	90-220	
		Структурированные		100	22	90-220	
	Алюминий - литье, легированный сплав	<=12% Si	Неструктурированные		75	23	90-220
			Структурированные		90	24	90-220
		>12% Si	Жаропрочные сплавы		130	25	80-160
	Сплавы меди	>1% Pb	Легкообрабатываемые		110	26	90-220
			Латунь		90	27	90-220
			Электролитная медь		100	28	90-220
	Неметаллические материалы	Реактопласты, волокниты				29	
		Твердая резина				30	
S	Жаропрочные сплавы	На основе железа	Отожженная		200	31	30-60
			Структурированные		280	32	20-50
		На основе никеля или кобальта	Отожженная		250	33	20-50
			Структурированные		350	34	20-50
			Литье		320	35	20-50
	Титан, титановые сплавы		Rm 400		36	20-50	
Альфа и бета сплавы структурированные		Rm 1050		37	20-50		
H	Закаленная сталь	Закалка		55HRC	38	20-50	
		Закалка		60HRC	39	20-50	
	Отбеленный чугун	Литье		400	40		
	Чугун с шаровидным графитом	Закалка		55HRC	41		

• Подробную информацию по группам материалов см. в Техническом Руководстве, "Таблица соответствия материалов"

■ Сталь
 ■ Нержавеющая сталь
 ■ Чугун
 ■ Цветные металлы
 ■ Жаропрочные сплавы
 ■ Закаленная сталь

Рекомендуемые условия резания



Режимы обработки для SPADE-RUSH

Подача (мм/об) и диаметр сверла			
Ø20 - Ø25.9	Ø26 - Ø29.9	Ø30 - Ø34.9	Ø35 - Ø41
0.30-0.50	0.30-0.50	0.30-0.50	0.35-0.55
0.30-0.50	0.30-0.50	0.30-0.50	0.35-0.55
0.30-0.50	0.30-0.50	0.30-0.50	0.35-0.55
0.30-0.50	0.30-0.50	0.30-0.50	0.35-0.55
0.30-0.50	0.30-0.50	0.30-0.50	0.35-0.55
0.25-0.45	0.25-0.45	0.25-0.45	0.30-0.50
0.25-0.45	0.25-0.45	0.25-0.45	0.30-0.50
0.25-0.45	0.25-0.45	0.25-0.45	0.30-0.50
0.25-0.45	0.25-0.45	0.25-0.45	0.30-0.50
0.25-0.35	0.25-0.35	0.25-0.35	0.30-0.40
0.25-0.35	0.25-0.35	0.25-0.35	0.30-0.40
0.15-0.30	0.15-0.30	0.15-0.30	0.20-0.35
0.15-0.30	0.15-0.30	0.15-0.30	0.20-0.35
0.15-0.30	0.15-0.30	0.15-0.30	0.20-0.35
0.35-0.55	0.35-0.55	0.35-0.55	0.40-0.60
0.35-0.55	0.35-0.55	0.35-0.55	0.40-0.60
0.35-0.55	0.35-0.55	0.35-0.55	0.40-0.60
0.35-0.55	0.35-0.55	0.35-0.55	0.40-0.60
0.35-0.55	0.35-0.55	0.35-0.55	0.40-0.60
0.40-0.60	0.40-0.60	0.40-0.60	0.50-0.70
0.40-0.60	0.40-0.60	0.40-0.60	0.50-0.70
0.40-0.60	0.40-0.60	0.40-0.60	0.50-0.70
0.40-0.60	0.40-0.60	0.40-0.60	0.50-0.70
0.40-0.60	0.40-0.60	0.40-0.60	0.50-0.70
0.40-0.60	0.40-0.60	0.40-0.60	0.50-0.70
0.40-0.60	0.40-0.60	0.40-0.60	0.50-0.70
0.10-0.20	0.10-0.20	0.15-0.25	0.15-0.25
0.10-0.20	0.10-0.20	0.15-0.25	0.15-0.25
0.10-0.20	0.10-0.20	0.15-0.25	0.15-0.25
0.10-0.20	0.10-0.20	0.15-0.25	0.15-0.25
0.10-0.20	0.10-0.20	0.15-0.25	0.15-0.25
0.10-0.20	0.10-0.20	0.15-0.25	0.15-0.25
0.10-0.20	0.10-0.20	0.15-0.25	0.15-0.25
0.10-0.20	0.10-0.20	0.15-0.25	0.15-0.25
0.10-0.20	0.10-0.20	0.15-0.25	0.15-0.25

Рекомендуемые условия резания

Режимы обработки для SOLID-3-DRILL

ISO	Материал	Состояние	Предел прочности (Н/мм ²)	Твердость по Бринеллю	Материал №	Скорость резания V _c (м/мин)	
P	Нелегированная сталь, литье, легкообрабатываемая сталь	<0.25%C	Отожженная	420	125	1	80-140
		>=0.25%C	Отожженная	650	190	2	80-130
		<0.55%C	Закаленная и отпущенная	850	250	3	80-120
		>=0.55%C	Отожженная	750	220	4	70-110
			Закаленная и отпущенная	1000	300	5	50-90
	Низколегированная сталь и литье (менее 5% легирующих добавок)	Закаленная и отпущенная	Отожженная	600	200	6	80-120
				930	275	7	70-110
				1000	300	8	50-90
				1200	350	9	40-70
	Высоколегированная сталь, литье и инструментальная сталь	Отожженная	680	200	10	50-90	
Закаленная и отпущенная		1100	325	11	40-80		
M	Нержавеющая сталь и литье	Ферритная/Мартенситная	680	200	12		
		Мартенситная	820	240	13		
		Аустенитная	600	180	14		
K	Серый чугун (GG)	Ферритный		160	15	80-140	
		Перлитный		250	16	70-120	
	Чугун с шаровидным графитом (GGG)	Ферритный		180	17	80-120	
		Перлитный		260	18	70-110	
	Ковкий чугун	Ферритный		130	19	80-120	
	Перлитный		230	20	70-110		
N	Деформируемые алюминиевые сплавы	Неструктурированные		60	21		
		Структурированные		100	22		
	Алюминий - литье, легированный сплав	<=12% Si	Неструктурированные		75	23	
			Структурированные		90	24	
		>12% Si	Жаропрочные сплавы		130	25	
	Сплавы меди	>1% Pb	Легкообрабатываемые		110	26	
			Латунь		90	27	
	Электродная медь		100	28			
S	Жаропрочные сплавы	На основе железа	Отожженная		200	31	
			Структурированные		280	32	
		На основе никеля или кобальта	Отожженная		250	33	
			Структурированные		350	34	
			Литье		320	35	
	Титан, титановые сплавы			Rm 400		36	
		Альфа и бета сплавы структурированные		Rm 1050		37	
H	Закаленная сталь	Закалка		55HRC	38		
		Закалка		60HRC	39		
	Отбеленный чугун	Литье		400	40		
	Чугун с шаровидным графитом	Закалка		55HRC	41		

• Подробную информацию по группам материалов см. в Техническом Руководстве, "Таблица соответствия материалов"

■ Сталь
 ■ Нержавеющая сталь
 ■ Чугун
 ■ Цветные металлы
 ■ Жаропрочные сплавы
 ■ Закаленная сталь

Рекомендуемые условия резания

Режимы обработки для SOLID-3-DRILL

Подача (мм/об) и диаметр сверла

Ø4 - Ø5	Ø5.1 - Ø6	Ø6.1 - Ø8	Ø8.1 - Ø10	Ø10.1 - Ø12
0.15-0.25	0.20-0.35	0.25-0.45	0.30-0.55	0.35-0.60
0.15-0.25	0.20-0.35	0.25-0.45	0.30-0.55	0.35-0.60
0.15-0.25	0.20-0.35	0.25-0.45	0.30-0.55	0.35-0.60
0.15-0.25	0.20-0.35	0.25-0.45	0.30-0.55	0.35-0.60
0.15-0.25	0.20-0.35	0.25-0.45	0.30-0.55	0.35-0.60
0.15-0.25	0.20-0.35	0.25-0.40	0.30-0.50	0.35-0.55
0.15-0.25	0.20-0.35	0.25-0.40	0.30-0.50	0.35-0.55
0.15-0.25	0.20-0.35	0.25-0.40	0.30-0.50	0.35-0.55
0.15-0.25	0.20-0.35	0.25-0.40	0.30-0.50	0.35-0.55
0.15-0.20	0.20-0.30	0.25-0.35	0.30-0.45	0.35-0.50
0.15-0.20	0.20-0.30	0.25-0.35	0.30-0.45	0.35-0.50
0.20-0.30	0.25-0.45	0.35-0.55	0.40-0.60	0.45-0.65
0.20-0.30	0.25-0.45	0.35-0.55	0.40-0.60	0.45-0.65
0.20-0.30	0.20-0.40	0.30-0.50	0.35-0.55	0.40-0.60
0.20-0.30	0.20-0.40	0.30-0.50	0.35-0.55	0.40-0.60
0.20-0.30	0.20-0.40	0.30-0.50	0.35-0.55	0.40-0.60
0.20-0.30	0.20-0.40	0.30-0.50	0.35-0.55	0.40-0.60

Рекомендуемые условия резания



Режимы обработки для H-DRILL

ISO	Материал	Состояние	Предел прочности (Н/мм ²)	Твердость по Бринеллю	Материал №	Скорость резания Vc (м/мин)		
P	Нелегированная сталь, литье, легкообрабатываемая сталь	<0.25%C	Отожженная	420	125	1	80-120	
		>=0.25%C	Отожженная	650	190	2	80-110	
		<0.55%C	Закаленная и отпущенная	850	250	3	70-100	
		>=0.55%C	Отожженная	750	220	4	70-100	
			Закаленная и отпущенная	1000	300	5	70-100	
	Низколегированная сталь и литье (менее 5% легирующих добавок)	Отожженная		600	200	6	70-90	
				930	275	7	70-90	
		Закаленная и отпущенная		1000	300	8	50-80	
				1200	350	9	40-70	
	Высоколегированная сталь, литье и инструментальная сталь	Отожженная		680	200	10	50-80	
Закаленная и отпущенная			1100	325	11	40-70		
M	Нержавеющая сталь и литье	Ферритная/Мартенситная		680	200	12	30-60	
		Мартенситная		820	240	13	30-60	
		Аустенитная		600	180	14	30-60	
K	Серый чугун (GG)	Ферритный			160	15	65-80	
		Перлитный			250	16	65-80	
	Чугун с шаровидным графитом (GGG)	Ферритный			180	17	85-105	
		Перлитный			260	18	75-90	
	Ковкий чугун	Ферритный			130	19	65-80	
Перлитный				230	20	65-80		
N	Деформируемые алюминиевые сплавы	Неструктурированные			60	21	70-200	
		Структурированные			100	22	70-200	
	Алюминий - литье, легированный сплав	<=12% Si	Неструктурированные			75	23	70-200
			Структурированные			90	24	70-200
		>12% Si	Жаропрочные сплавы			130	25	70-150
	Сплавы меди	>1% Pb	Легкообрабатываемые			110	26	70-200
			Латунь			90	27	70-200
			Электролитная медь			100	28	70-200
	Неметаллические материалы	Реактопласты, волокниты					29	
		Твердая резина						30
S	Жаропрочные сплавы	На основе железа	Отожженная			200	31	15-40
			Структурированные			280	32	15-40
		На основе никеля или кобальта	Отожженная			250	33	15-40
			Структурированные			350	34	15-40
			Литье			320	35	15-40
	Титан, титановые сплавы			Rm 400			36	
Альфа и бета сплавы структурированные				Rm 1050			37	
H	Закаленная сталь	Закалка				55HRC	38	10-40
		Закалка				60HRC	39	10-40
	Отбеленный чугун	Литье				400	40	
Чугун с шаровидным графитом	Закалка					55HRC	41	

• Подробную информацию по группам материалов см. в Техническом Руководстве, "Таблица соответствия материалов"

■ Сталь
 ■ Нержавеющая сталь
 ■ Чугун
 ■ Цветные металлы
 ■ Жаропрочные сплавы
 ■ Закаленная сталь

Рекомендуемые условия резания



Режимы обработки для H-DRILL

Подача (мм/об) и диаметр сверла		
Ø3 - Ø5	Ø5.1 - Ø8	Ø8.1 - Ø12
0.10-0.20	0.15-0.25	0.20-0.30
0.10-0.20	0.15-0.25	0.20-0.30
0.10-0.20	0.15-0.25	0.20-0.30
0.10-0.20	0.15-0.25	0.20-0.30
0.10-0.20	0.15-0.25	0.20-0.30
0.10-0.20	0.15-0.25	0.20-0.30
0.10-0.20	0.15-0.25	0.20-0.30
0.10-0.20	0.15-0.25	0.20-0.30
0.10-0.20	0.15-0.25	0.20-0.30
0.08-0.18	0.10-0.20	0.15-0.25
0.08-0.18	0.10-0.20	0.15-0.25
0.06-0.12	0.10-0.15	0.12-0.18
0.06-0.12	0.10-0.15	0.12-0.18
0.06-0.12	0.10-0.15	0.12-0.18
0.10-0.20	0.15-0.25	0.20-0.30
0.10-0.20	0.15-0.25	0.20-0.30
0.10-0.20	0.15-0.25	0.20-0.30
0.10-0.20	0.15-0.25	0.20-0.30
0.10-0.20	0.15-0.25	0.20-0.30
0.10-0.25	0.15-0.35	0.25-0.45
0.10-0.25	0.15-0.35	0.25-0.45
0.10-0.25	0.15-0.35	0.25-0.45
0.10-0.25	0.15-0.35	0.25-0.45
0.10-0.25	0.15-0.35	0.25-0.45
0.08-0.18	0.15-0.25	0.20-0.35
0.08-0.18	0.15-0.25	0.20-0.35
0.08-0.18	0.15-0.25	0.20-0.35
0.02-0.08	0.04-0.10	0.06-0.12
0.02-0.08	0.04-0.10	0.06-0.12
0.02-0.08	0.04-0.10	0.06-0.12
0.02-0.08	0.04-0.10	0.06-0.12
0.02-0.08	0.04-0.10	0.06-0.12
0.02-0.08	0.04-0.10	0.06-0.12
0.02-0.08	0.04-0.10	0.06-0.12

Режимы обработки для TOP-CAP

ISO	Материал	Состояние	Предел прочности (Н/мм ²)	Твердость по Бринеллю	Материал №	
P	Нелегированная сталь, литье, легкообрабатываемая сталь	<0.25%C	Отожженная	420	125	1
		>=0.25%C	Отожженная	650	190	2
		<0.55%C	Закаленная и отпущенная	850	250	3
		>=0.55%C	Отожженная	750	220	4
			Закаленная и отпущенная	1000	300	5
	Низколегированная сталь и литье (менее 5% легирующих добавок)	Отожженная		600	200	6
				930	275	7
		Закаленная и отпущенная		1000	300	8
				1200	350	9
	Высоколегированная сталь, литье и инструментальная сталь	Отожженная	680	200	10	
		Закаленная и отпущенная	1100	325	11	
M	Нержавеющая сталь и литье	Ферритная/Мартенситная	680	200	12	
		Мартенситная	820	240	13	
		Аустенитная	600	180	14	
K	Серый чугун (GG)	Ферритный		160	15	
		Перлитный		250	16	
	Чугун с шаровидным графитом (GGG)	Ферритный		180	17	
		Перлитный		260	18	
	Ковкий чугун	Ферритный		130	19	
	Перлитный		230	20		
N	Деформируемые алюминиевые сплавы	Неструктурированные		60	21	
		Структурированные		100	22	
	Алюминий - литье, легированный сплав	<=12% Si	Неструктурированные		75	23
			Структурированные		90	24
		>12% Si	Жаропрочные сплавы		130	25
	Сплавы меди	>1% Pb	Легкообрабатываемые		110	26
			Латунь		90	27
			Электролитная медь		100	28
	Неметаллические материалы	Реактопласты, волокниты				29
		Твердая резина				30
S	Жаропрочные сплавы	На основе железа	Отожженная		200	31
			Структурированные		280	32
		На основе никеля или кобальта	Отожженная		250	33
			Структурированные		350	34
	Литье			320	35	
		Титан, титановые сплавы		Rm 400		36
H	Закаленная сталь	Альфа и бета сплавы структурированные		Rm 1050	37	
		Закалка			55HRC	38
	Закалка				60HRC	39
	Отбеленный чугун	Литье			400	40
Чугун с шаровидным графитом	Закалка			55HRC	41	

• Подробную информацию по группам материалов см. в Техническом Руководстве, "Таблица соответствия материалов"

■ Сталь
 ■ Нержавеющая сталь
 ■ Чугун
 ■ Цветные металлы
 ■ Жаропрочные сплавы
 ■ Закаленная сталь

Рекомендуемые условия резания



Режимы обработки для TOP-CAP

Сверление		Точение и расточка		Обработка канавок	
Vc (м/мин)	Подача (мм/об)	Vc (м/мин)	Подача (мм/об)	Vc (м/мин)	Подача (мм/об)
120-260	0.05-0.06	140-280	0.04-0.14	120-250	0.04-0.25
80-190	0.05-0.15	90-200	0.04-0.12	80-180	0.04-0.25
100-280	0.06-0.18	100-200	0.04-0.15	80-180	0.04-0.25
100-280	0.06-0.18	100-200	0.04-0.15	80-180	0.04-0.25
100-280	0.06-0.18	100-200	0.04-0.15	80-180	0.04-0.25
100-280	0.06-0.18	100-200	0.04-0.15	80-180	0.04-0.25
60-180	0.04-0.15	80-180	0.07-0.12	60-160	0.04-0.25
60-180	0.04-0.15	80-180	0.07-0.12	60-160	0.04-0.25
60-180	0.04-0.15	80-180	0.07-0.12	60-160	0.04-0.25
80-190	0.05-0.15	80-200	0.04-0.12	80-160	0.04-0.25
50-150	0.04-0.14	60-150	0.04-0.12	50-120	0.04-0.25
50-210	0.04-0.15	60-230	0.07-0.12	50-200	0.04-0.25
50-210	0.04-0.15	60-230	0.07-0.12	50-200	0.04-0.25
50-210	0.04-0.15	60-230	0.07-0.12	50-200	0.04-0.25
100-300	0.06-0.23	120-230	0.07-0.2	100-200	0.04-0.25
100-300	0.06-0.23	120-230	0.07-0.2	100-200	0.04-0.25
100-300	0.06-0.23	120-230	0.07-0.2	100-200	0.04-0.25
100-300	0.06-0.23	120-230	0.07-0.2	100-200	0.04-0.25
100-200	0.06-0.15	120-230	0.04-0.13	100-200	0.04-0.25
100-200	0.06-0.15	120-230	0.04-0.13	100-200	0.04-0.25
120-500	0.05-0.3	120-700	0.04-0.25	100-700	0.04-0.25
120-500	0.05-0.3	120-700	0.04-0.25	100-700	0.04-0.25
120-500	0.05-0.3	120-700	0.04-0.25	100-700	0.04-0.25
120-500	0.05-0.3	120-700	0.04-0.25	100-700	0.04-0.25
80-380	0.05-0.23	80-500	0.04-0.2	80-350	0.04-0.25
80-380	0.05-0.23	80-500	0.04-0.2	80-350	0.04-0.25
80-380	0.05-0.23	80-500	0.04-0.2	80-350	0.04-0.25
50-140	0.04-0.14	50-160	0.04-0.12	50-140	0.04-0.25
50-140	0.04-0.14	50-160	0.04-0.12	50-140	0.04-0.25
20-50	0.04-0.05	20-80	0.04-0.05	20-50	0.04-0.05
20-50	0.04-0.05	20-80	0.04-0.05	20-50	0.04-0.05
20-50	0.04-0.05	20-80	0.04-0.05	20-50	0.04-0.05
20-50	0.04-0.05	20-80	0.04-0.05	20-50	0.04-0.05
20-50	0.04-0.05	20-80	0.04-0.05	20-50	0.04-0.05
30-60	0.04-0.05	30-100	0.04-0.05	30-80	0.04-0.05
30-60	0.04-0.05	30-100	0.04-0.05	30-80	0.04-0.05
20-40	0.04-0.05	20-70	0.04-0.05	20-50	0.04-0.05
20-40	0.04-0.05	20-70	0.04-0.05	20-50	0.04-0.05
20-40	0.04-0.05	20-70	0.04-0.05	20-50	0.04-0.05
20-40	0.04-0.05	20-70	0.04-0.05	20-50	0.04-0.05

Рекомендуемые условия резания



Режимы обработки для ТВТА 3/5/7/9 и ТВТА-R

ISO	Материал	Состояние	Предел прочности (Н/мм ²)	Твердость по Бринеллю	Материал №	Скорость резания Vc (м/мин)		
P	Нелегированная сталь, литье, легкообрабатываемая сталь	<0.25%C	Отожженная	420	125	1	60-120	
		>=0.25%C	Отожженная	650	190	2	60-120	
		<0.55%C	Закалённая и отпущенная	850	250	3	60-120	
		>=0.55%C	Отожженная	750	220	4	60-120	
			Закалённая и отпущенная	1000	300	5	50-100	
	Низколегированная сталь и литье (менее 5% легирующих добавок)		Отожженная		600	200	6	50-100
					930	275	7	50-100
			Закалённая и отпущенная		1000	300	8	50-100
					1200	350	9	50-100
	Высоколегированная сталь, литье и инструментальная сталь		Отожженная	680	200	10	60-120	
Закалённая и отпущенная			1100	325	11	60-120		
M	Нержавеющая сталь и литье	Ферритная/Мартенситная	680	200	12	60-110		
		Мартенситная	820	240	13	60-110		
		Аустенитная	600	180	14	60-110		
K	Серый чугун (GG)	Ферритный		160	15	60-100		
		Перлитный		250	16	60-100		
	Чугун с шаровидным графитом (GGG)	Ферритный		180	17	60-100		
		Перлитный		260	18	60-100		
	Ковкий чугун	Ферритный		130	19	60-100		
Перлитный			230	20	60-100			
N	Деформируемые алюминиевые сплавы	Неструктурированные		60	21	60-130		
		Структурированные		100	22	60-130		
	Алюминий - литье, легированный сплав	<=12% Si	Неструктурированные		75	23	60-130	
			Структурированные		90	24	60-130	
		>12% Si	Жаропрочные сплавы		130	25	60-130	
	Сплавы меди	>1% Pb	Легкообрабатываемые		110	26	60-130	
			Латунь		90	27	60-130	
			Электролитная медь		100	28	60-130	
	Неметаллические материалы		Реактопласты, волокниты			29		
			Твердая резина			30		
S	Жаропрочные сплавы	На основе железа	Отожженная		200	31	20-65	
			Структурированные		280	32	20-65	
		На основе никеля или кобальта	Отожженная		250	33	20-65	
			Структурированные		350	34	20-65	
			Литье		320	35	20-65	
	Титан, титановые сплавы		Rm 400		36	30-100		
Альфа и бета сплавы структурированные		Rm 1050		37	30-100			
H	Закаленная сталь	Закалка		55HRC	38			
		Закалка		60HRC	39			
	Отбеленный чугун	Литье		400	40			
	Чугун с шаровидным графитом	Закалка		55HRC	41			

• Подробную информацию по группам материалов см. в Техническом Руководстве, "Таблица соответствия материалов"

■ Сталь
 ■ Нержавеющая сталь
 ■ Чугун
 ■ Цветные металлы
 ■ Жаропрочные сплавы
 ■ Закаленная сталь

Рекомендуемые условия резания



Режимы обработки для ТВТА 3/5/7/9 и ТВТА-R

Подача (мм/об) и диаметр сверла

Ø38.00 - Ø39.99	Ø40.00 - Ø51.99	Ø52.00 - Ø63.99	Ø64.00 - Ø84.99	Ø85.00 -
0.08-0.15	0.10-0.20	0.13-0.23	0.15-0.25	0.18-0.30
0.08-0.15	0.10-0.20	0.13-0.23	0.15-0.25	0.18-0.30
0.08-0.15	0.10-0.20	0.13-0.23	0.15-0.25	0.18-0.30
0.08-0.15	0.10-0.20	0.13-0.23	0.15-0.25	0.18-0.30
0.08-0.15	0.10-0.20	0.13-0.23	0.15-0.25	0.18-0.30
0.08-0.15	0.10-0.20	0.13-0.23	0.15-0.25	0.18-0.30
0.08-0.15	0.10-0.20	0.13-0.23	0.15-0.25	0.18-0.30
0.08-0.15	0.10-0.20	0.13-0.23	0.15-0.25	0.18-0.30
0.08-0.15	0.10-0.20	0.13-0.23	0.15-0.25	0.18-0.30
0.08-0.15	0.10-0.20	0.13-0.23	0.15-0.25	0.18-0.30
0.08-0.15	0.10-0.20	0.13-0.23	0.15-0.25	0.18-0.30
0.08-0.15	0.10-0.20	0.13-0.23	0.15-0.25	0.18-0.30
0.08-0.15	0.10-0.20	0.13-0.23	0.15-0.25	0.18-0.30
0.08-0.15	0.10-0.20	0.13-0.23	0.15-0.25	0.18-0.30
0.08-0.13	0.10-0.15	0.13-0.18	0.15-0.20	0.18-0.23
0.08-0.13	0.10-0.15	0.13-0.18	0.15-0.20	0.18-0.23
0.08-0.13	0.10-0.15	0.13-0.18	0.15-0.20	0.18-0.23
0.08-0.13	0.10-0.15	0.13-0.18	0.15-0.20	0.18-0.23
0.08-0.13	0.10-0.15	0.13-0.18	0.15-0.20	0.18-0.23
0.08-0.13	0.10-0.15	0.13-0.18	0.15-0.20	0.18-0.23
0.08-0.20	0.10-0.25	0.13-0.28	0.15-0.30	0.18-0.33
0.08-0.20	0.10-0.25	0.13-0.28	0.15-0.30	0.18-0.33
0.08-0.20	0.10-0.25	0.13-0.28	0.15-0.30	0.18-0.33
0.08-0.20	0.10-0.25	0.13-0.28	0.15-0.30	0.18-0.33
0.08-0.20	0.10-0.25	0.13-0.28	0.15-0.30	0.18-0.33
0.08-0.20	0.10-0.25	0.13-0.28	0.15-0.30	0.18-0.33
0.08-0.20	0.10-0.25	0.13-0.28	0.15-0.30	0.18-0.33
0.08-0.15	0.10-0.20	0.13-0.23	0.15-0.25	0.18-0.30
0.08-0.15	0.10-0.20	0.13-0.23	0.15-0.25	0.18-0.30
0.08-0.15	0.10-0.20	0.13-0.23	0.15-0.25	0.18-0.30
0.08-0.15	0.10-0.20	0.13-0.23	0.15-0.25	0.18-0.30
0.08-0.15	0.10-0.20	0.13-0.23	0.15-0.25	0.18-0.30
0.08-0.15	0.10-0.20	0.13-0.23	0.15-0.25	0.18-0.30

Рекомендуемые условия резания



Режимы обработки для ТВТА-FB

ISO	Материал	Состояние	Предел прочности (Н/мм ²)	Твердость по Бринеллю	Материал №	Скорость резания Vc(м/мин)		
P	Нелегированная сталь, литье, легкообрабатываемая сталь	<0.25%C	Отожженная	420	125	1	70-130	
		>=0.25%C	Отожженная	650	190	2	70-130	
		<0.55%C	Закаленная и отпущенная	850	250	3	70-130	
		>=0.55%C	Отожженная	750	220	4	70-130	
			Закаленная и отпущенная	1000	300	5	70-130	
	Низколегированная сталь и литье (менее 5% легирующих добавок)		Отожженная		600	200	6	70-120
					930	275	7	60-120
			Закаленная и отпущенная		1000	300	8	60-120
					1200	350	9	60-120
	Высоколегированная сталь, литье и инструментальная сталь		Отожженная	680	200	10	70-130	
Закаленная и отпущенная			1100	325	11	70-130		
M	Нержавеющая сталь и литье	Ферритная/Мартенситная	680	200	12	70-130		
		Мартенситная	820	240	13	70-130		
		Аустенитная	600	180	14	70-130		
K	Серый чугун (GG)	Ферритный		160	15	60-110		
		Перлитный		250	16	60-110		
	Чугун с шаровидным графитом (GGG)	Ферритный		180	17	50-110		
		Перлитный		260	18	50-110		
	Ковкий чугун	Ферритный		130	19	70-110		
Перлитный			230	20	70-110			
N	Деформируемые алюминиевые сплавы	Неструктурированные		60	21	65-130		
		Структурированные		100	22	65-130		
	Алюминий - литье, легированный сплав	<=12% Si	Неструктурированные		75	23	65-130	
			Структурированные		90	24	65-130	
		>12% Si	Жаропрочные сплавы		130	25	65-130	
		>1% Pb	Легкообрабатываемые		110	26	65-130	
	Сплавы меди	Латунь			90	27	65-130	
		Электролитная медь			100	28	65-130	
	Неметаллические материалы	Реактопласты, волокниты				29		
		Твердая резина				30		
S	Жаропрочные сплавы	На основе железа	Отожженная		200	31	20-50	
			Структурированные		280	32	20-50	
		На основе никеля или кобальта	Отожженная		250	33	20-50	
			Структурированные		350	34	20-50	
			Литье		320	35	20-50	
	Титан, титановые сплавы		Rm 400			36	30-60	
Альфа и бета сплавы структурированные		Rm 1050			37	30-60		
H	Закаленная сталь	Закалка			55HRC	38		
		Закалка			60HRC	39		
	Отбеленный чугун	Литье			400	40		
	Чугун с шаровидным графитом	Закалка			55HRC	41		

• Подробную информацию по группам материалов см. в Техническом Руководстве, "Таблица соответствия материалов"

■ Сталь
 ■ Нержавеющая сталь
 ■ Чугун
 ■ Цветные металлы
 ■ Жаропрочные сплавы
 ■ Закаленная сталь

Подача (мм/об) и диаметр сверла			
Ø25.00 - Ø43.00	Ø43.01 - Ø65.00		
0.10-0.30	0.12-0.35		
0.10-0.30	0.12-0.35		
0.10-0.30	0.12-0.35		
0.10-0.30	0.12-0.35		
0.10-0.30	0.12-0.35		
0.10-0.30	0.12-0.35		
0.10-0.30	0.12-0.35		
0.10-0.30	0.12-0.35		
0.10-0.30	0.12-0.35		
0.10-0.30	0.12-0.35		
0.10-0.30	0.12-0.35		
0.10-0.30	0.12-0.35		
0.10-0.30	0.12-0.35		
0.10-0.30	0.12-0.35		
0.10-0.30	0.12-0.35		
0.10-0.25	0.12-0.35		
0.10-0.25	0.12-0.35		
0.10-0.25	0.12-0.35		
0.10-0.25	0.12-0.35		
0.10-0.25	0.12-0.35		
0.10-0.25	0.12-0.35		
0.10-0.25	0.12-0.35		
0.08-0.23	0.12-0.27		
0.08-0.23	0.12-0.27		
0.08-0.23	0.12-0.27		
0.08-0.23	0.12-0.27		
0.08-0.23	0.12-0.27		
0.08-0.23	0.12-0.27		
0.08-0.23	0.12-0.27		
0.08-0.23	0.12-0.27		
0.08-0.23	0.12-0.27		
0.08-0.23	0.12-0.27		
0.08-0.23	0.12-0.27		
0.08-0.23	0.12-0.27		
0.08-0.23	0.12-0.27		

Рекомендуемые условия резания



Режимы обработки для ВТА и BTS

ISO	Материал	Состояние	Предел прочности (Н/мм ²)	Твердость по Бринеллю	Материал №	Скорость резания Vc(м/мин)	
P	Нелегированная сталь, литье, легкообрабатываемая сталь	<0.25%C	Отожженная	420	125	1	70-120
		≥0.25%C	Отожженная	650	190	2	70-120
		<0.55%C	Закалённая и отпущенная	850	250	3	40-70
		≥0.55%C	Отожженная	750	220	4	70-120
			Закалённая и отпущенная	1000	300	5	55-100
	Низколегированная сталь и литье (менее 5% легирующих добавок)	Отожженная		600	200	6	70-100
				930	275	7	55-100
		Закалённая и отпущенная		1000	300	8	55-100
				1200	350	9	55-100
	Высоколегированная сталь, литье и инструментальная сталь	Отожженная		680	200	10	50-85
Закалённая и отпущенная			1100	325	11	55-100	
M	Нержавеющая сталь и литье	Ферритная/Мартенситная		680	200	12	60-100
		Мартенситная		820	240	13	60-100
		Аустенитная		600	180	14	60-100
K	Серый чугун (GG)	Ферритный			160	15	60-100
		Перлитный			250	16	60-100
	Чугун с шаровидным графитом (GGG)	Ферритный			180	17	80-100
		Перлитный			260	18	80-100
	Ковкий чугун	Ферритный			130	19	50-100
Перлитный				230	20	50-100	
N	Деформируемые алюминиевые сплавы	Неструктурированные		60	21	65-130	
		Структурированные		100	22	65-100	
	Алюминий - литье, легированный сплав	<=12% Si	Неструктурированные		75	23	65-130
			Структурированные		90	24	65-130
		>12% Si	Жаропрочные сплавы		130	25	65-130
	Сплавы меди	>1% Pb	Легкообрабатываемые		110	26	65-130
			Латунь		90	27	65-130
			Электролитная медь		100	28	65-130
	Неметаллические материалы	Реактопласты, волокниты				29	
		Твердая резина				30	
S	Жаропрочные сплавы	На основе железа	Отожженная		200	31	10-50
			Структурированные		280	32	10-50
		На основе никеля или кобальта	Отожженная		250	33	10-50
			Структурированные		350	34	10-50
	Титан, титановые сплавы	Литье			320	35	10-50
			Rm 400		36	30-50	
H	Закаленная сталь	Закалка			55HRC	38	
		Закалка			60HRC	39	
	Отбеленный чугун	Литье			400	40	
	Чугун с шаровидным графитом	Закалка			55HRC	41	

• Подробную информацию по группам материалов см. в Техническом Руководстве, "Таблица соответствия материалов"

■ Сталь
 ■ Нержавеющая сталь
 ■ Чугун
 ■ Цветные металлы
 ■ Жаропрочные сплавы
 ■ Закаленная сталь

Рекомендуемые условия резания



Режимы обработки для ВТА и ВТС

Подача (мм/об) и диаметр сверла

Ø8.00 - Ø20.00	Ø15.60 - Ø20.00	Ø20.01 - Ø31.00	Ø31.01 - Ø43.00	Ø43.01 - Ø65.00
0.05-0.13	0.08-0.15	0.10-0.17	0.13-0.20	0.16-0.30
0.05-0.13	0.08-0.15	0.10-0.17	0.13-0.20	0.16-0.30
0.05-0.13	0.08-0.15	0.10-0.17	0.13-0.20	0.16-0.30
0.05-0.13	0.08-0.15	0.10-0.17	0.13-0.20	0.16-0.30
0.05-0.10	0.08-0.12	0.10-0.15	0.13-0.17	0.15-0.28
0.05-0.13	0.08-0.15	0.10-0.17	0.13-0.20	0.16-0.30
0.05-0.10	0.08-0.12	0.10-0.15	0.13-0.17	0.15-0.28
0.05-0.10	0.08-0.12	0.10-0.15	0.13-0.17	0.15-0.28
0.05-0.13	0.08-0.15	0.10-0.17	0.13-0.20	0.16-0.30
0.05-0.10	0.08-0.12	0.10-0.15	0.13-0.17	0.15-0.28
0.05-0.13	0.08-0.15	0.10-0.28	0.13-0.30	0.16-0.35
0.05-0.13	0.08-0.15	0.10-0.28	0.13-0.30	0.16-0.35
0.05-0.12	0.05-0.12	0.08-0.25	0.10-0.28	0.15-0.33
0.05-0.13	0.06-0.13	0.08-0.18	0.10-0.20	0.15-0.25
0.05-0.13	0.06-0.13	0.08-0.18	0.10-0.20	0.15-0.25
0.05-0.13	0.08-0.15	0.10-0.17	0.13-0.20	0.16-0.30
0.05-0.13	0.08-0.15	0.10-0.17	0.13-0.20	0.16-0.30
0.05-0.13	0.06-0.13	0.08-0.18	0.10-0.20	0.15-0.25
0.05-0.13	0.06-0.13	0.08-0.18	0.10-0.20	0.15-0.25
0.05-0.13	0.08-0.15	0.10-0.20	0.15-0.25	0.16-0.30
0.05-0.13	0.08-0.15	0.10-0.20	0.15-0.25	0.16-0.30
0.05-0.13	0.08-0.15	0.10-0.20	0.15-0.25	0.16-0.30
0.05-0.13	0.08-0.15	0.10-0.20	0.15-0.25	0.16-0.30
0.05-0.13	0.08-0.15	0.10-0.20	0.15-0.25	0.16-0.30
0.05-0.13	0.08-0.15	0.10-0.20	0.15-0.25	0.16-0.30
0.05-0.13	0.08-0.15	0.10-0.20	0.15-0.25	0.16-0.30
0.05-0.12	0.06-0.12	0.08-0.15	0.12-0.18	0.15-0.25
0.05-0.12	0.06-0.12	0.08-0.15	0.12-0.18	0.15-0.25
0.05-0.12	0.06-0.12	0.08-0.15	0.12-0.18	0.15-0.25
0.05-0.12	0.06-0.12	0.08-0.15	0.12-0.18	0.15-0.25
0.05-0.12	0.06-0.12	0.08-0.15	0.12-0.18	0.15-0.25
0.05-0.10	0.05-0.10	0.08-0.12	0.10-0.15	0.12-0.20
0.05-0.10	0.05-0.10	0.08-0.12	0.10-0.15	0.12-0.20

Рекомендуемые условия резания



Режимы обработки для TRGD / TRGDL / TBTA-TR

ISO	Материал	Состояние	Предел прочности (Н/мм ²)	Твердость по Бринеллю	Материал №	
P	Нелегированная сталь, литье, легкообрабатываемая сталь	<0.25%C	Отожженная	420	125	1
		>=0.25%C	Отожженная	650	190	2
		<0.55%C	Закаленная и отпущенная	850	250	3
		>=0.55%C	Отожженная	750	220	4
			Закаленная и отпущенная	1000	300	5
	Низколегированная сталь и литье (менее 5% легирующих добавок)	Отожженная		600	200	6
				930	275	7
		Закаленная и отпущенная		1000	300	8
				1200	350	9
	Высоколегированная сталь, литье и инструментальная сталь	Отожженная	680	200	10	
		Закаленная и отпущенная	1100	325	11	
M	Нержавеющая сталь и литье	Ферритная/Мартенситная	680	200	12	
		Мартенситная	820	240	13	
		Аустенитная	600	180	14	
K	Серый чугун (GG)	Ферритный		160	15	
		Перлитный		250	16	
	Чугун с шаровидным графитом (GGG)	Ферритный		180	17	
		Перлитный		260	18	
	Ковкий чугун	Ферритный		130	19	
Перлитный			230	20		
N	Деформируемые алюминиевые сплавы	Неструктурированные		60	21	
		Структурированные		100	22	
	Алюминий - литье, легированный сплав	<=12% Si	Неструктурированные		75	23
			Структурированные		90	24
		>12% Si	Жаропрочные сплавы		130	25
	Сплавы меди	>1% Pb	Легкообрабатываемые		110	26
			Латунь		90	27
			Электролитная медь		100	28
	Неметаллические материалы	Реактопласты, волокниты				29
		Твердая резина				30
S	Жаропрочные сплавы	На основе железа	Отожженная		200	31
			Структурированные		280	32
		На основе никеля или кобальта	Отожженная		250	33
			Структурированные		350	34
	Титан, титановые сплавы	Литье			320	35
				Rm 400		36
H	Закаленная сталь	Закалка			55 HRC	38
		Закалка			60 HRC	39
	Отбеленный чугун	Литье			400	40
	Чугун с шаровидным графитом	Закалка			55 HRC	41

• Подробную информацию по группам материалов см. в Техническом Руководстве, "Таблица соответствия материалов"

■ Сталь
 ■ Нержавеющая сталь
 ■ Чугун
 ■ Цветные металлы
 ■ Жаропрочные сплавы
 ■ Закаленная сталь

Рекомендуемые условия резания



Режимы обработки для TRGD / TRGDL / TBTA-TR

Подача (мм/об) и диаметр сверла					
Скорость резания Vc(м/мин)	TRGD / TRGDL			Скорость резания Vc(м/мин)	TBTA-TR
	Ø14.00-Ø15.99	Ø16.00-Ø28.00	Ø28.01-Ø40.00		Ø16.00-Ø28.00
80-140	0.05-0.10	0.05-0.10	0.05-0.15	90-130	0.15-0.20
80-140	0.05-0.10	0.05-0.10	0.05-0.15	90-130	0.15-0.20
80-140	0.05-0.16	0.05-0.20	0.05-0.20	90-130	0.15-0.20
80-140	0.05-0.16	0.05-0.20	0.05-0.20	70-130	0.10-0.25
80-140	0.05-0.16	0.05-0.20	0.05-0.20	70-130	0.10-0.25
80-140	0.05-0.10	0.05-0.10	0.05-0.15	70-120	0.10-0.25
80-120	0.05-0.16	0.05-0.20	0.05-0.20	60-120	0.10-0.25
80-120	0.05-0.16	0.05-0.20	0.05-0.20	60-120	0.10-0.25
80-120	0.05-0.16	0.05-0.20	0.05-0.20	60-120	0.10-0.25
80-140	0.05-0.10	0.05-0.10	0.05-0.15	70-130	0.10-0.25
80-120	0.05-0.16	0.05-0.20	0.05-0.20	70-130	0.10-0.25
60-100	0.05-0.10	0.05-0.10	0.05-0.15	80-130	0.06-0.10
60-100	0.05-0.10	0.05-0.10	0.05-0.15	80-130	0.06-0.10
60-100	0.05-0.10	0.05-0.10	0.05-0.15	80-130	0.06-0.10
80-140	0.05-0.25	0.05-0.30	0.05-0.30	50-110	0.10-0.20
80-140	0.05-0.25	0.05-0.30	0.05-0.30	50-110	0.10-0.20
80-140	0.05-0.25	0.05-0.30	0.05-0.30	60-110	0.10-0.20
80-140	0.05-0.25	0.05-0.30	0.05-0.30	60-110	0.10-0.20
80-140	0.05-0.25	0.05-0.30	0.05-0.30	70-110	0.10-0.20
80-140	0.05-0.25	0.05-0.30	0.05-0.30	70-110	0.10-0.20
100-200	0.05-0.20	0.05-0.20	0.05-0.25	65-130	0.08-0.18
100-200	0.05-0.20	0.05-0.20	0.05-0.25	65-130	0.08-0.18
100-200	0.05-0.20	0.05-0.20	0.05-0.25	65-130	0.08-0.18
				65-130	0.08-0.18
				65-130	0.08-0.18
				65-130	0.08-0.18
				65-130	0.08-0.18
				65-130	0.08-0.18
				65-130	0.08-0.18
20-50	0.04-0.08	0.04-0.10	0.04-0.13	20-50	0.08-0.18
20-50	0.04-0.08	0.04-0.10	0.04-0.13	20-50	0.08-0.18
20-50	0.04-0.08	0.04-0.10	0.04-0.13	20-50	0.08-0.18
20-50	0.04-0.08	0.04-0.10	0.04-0.13	20-50	0.08-0.18
20-50	0.04-0.08	0.04-0.10	0.04-0.13	20-50	0.08-0.18
30-60	0.05-0.13	0.05-0.15	0.05-0.18	30-60	0.08-0.18
30-60	0.05-0.13	0.05-0.15	0.05-0.18	30-60	0.08-0.18
50-100	0.04-0.08	0.04-0.10	0.04-0.13		
50-100	0.04-0.08	0.04-0.10	0.04-0.13		
50-100	0.04-0.08	0.04-0.10	0.04-0.13		
50-100	0.04-0.08	0.04-0.10	0.04-0.13		



Инструмент для развертывания отверстий

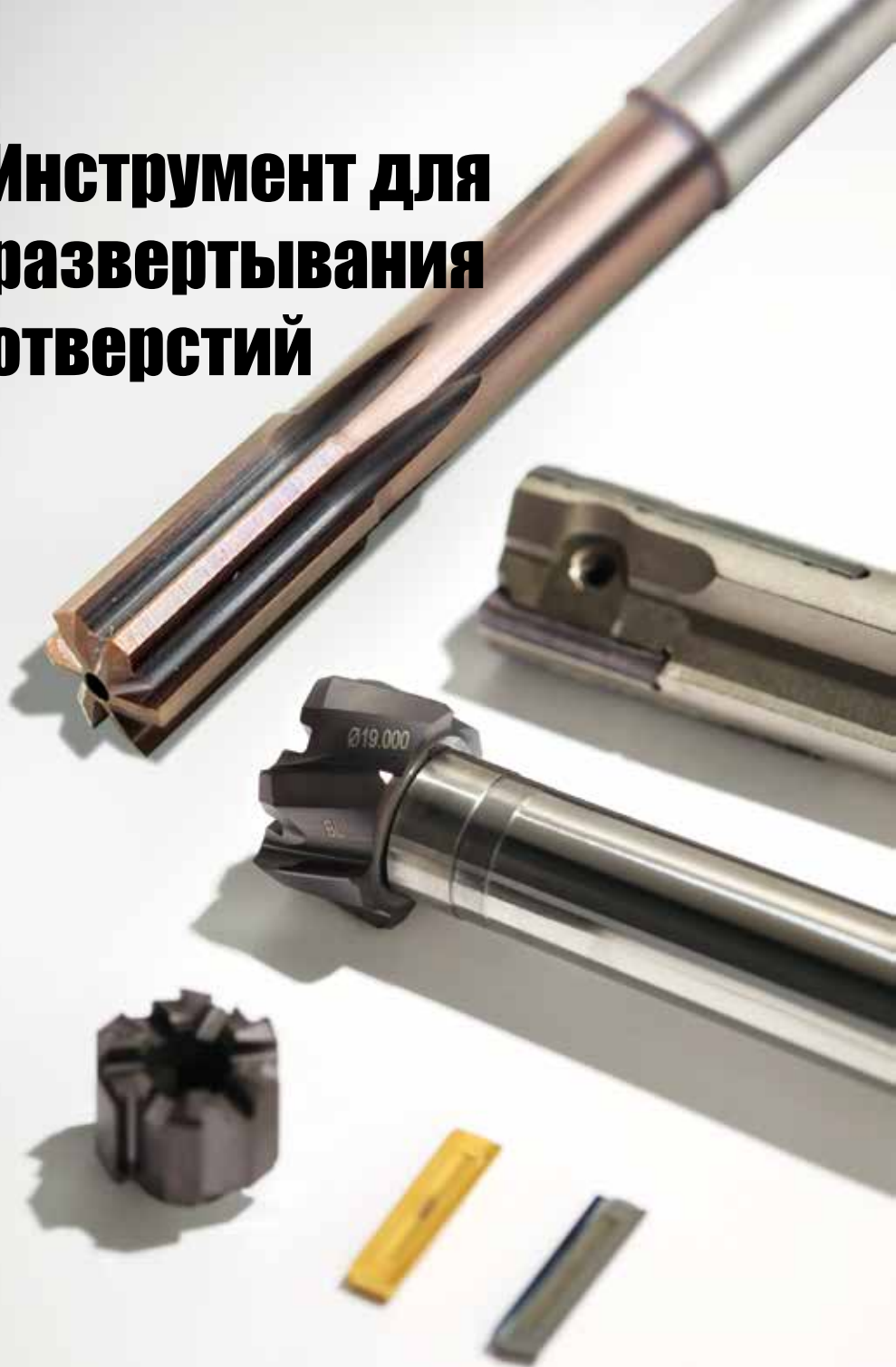

Монолитная развертка для глухих отверстий



• Прямой зуб - DIN1420

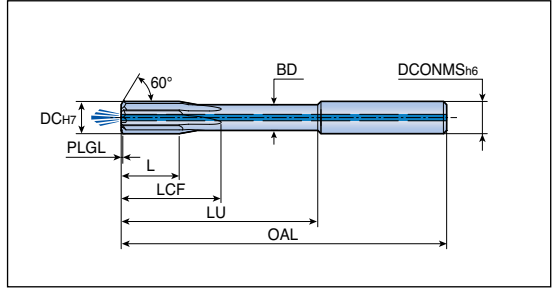

Обозначение	Размеры (мм)								NOF	Сплав ТТ5040
	DC	L	PLGL	LCF	BD	LU	OAL	DCONMS		
TS-S0300-NS	3.0	12	0.25	21	2.4	31	60	4.0	4	●
S0400-NS	4.0	12	0.3	17	3.4	40	68	6.0	6	●
S0500-NS	5.0	12	0.3	17	3.8	40	76	6.0	6	●
S0600-NS	6.0	12	0.3	17	4.5	40	76	6.0	6	●
S0700-NS	7.0	15	0.4	20	5.6	65	101	8.0	6	●
S0800-NS	8.0	15	0.4	20	6.4	65	101	8.0	6	●
S0900-NS	9.0	18	0.4	23	7.2	61	101	10.0	6	●
S1000-NS	10.0	18	0.5	23	8.0	61	101	10.0	6	●
S1050-NS	10.5	18	0.5	23	8.4	85	130	12.0	6	●
S1100-NS	11.0	18	0.5	23	8.8	85	130	12.0	6	●
S1150-NS	11.5	18	0.5	23	9.2	85	130	12.0	6	●
S1200-NS	12.0	18	0.5	23	9.6	85	130	12.0	6	●



• Специальные диаметры доступны по запросу
 • NOF: Число зубьев

• Стандартная позиция

Монолитная развертка для сквозных отверстий



- Левосторонний спиральный зуб - DIN1420

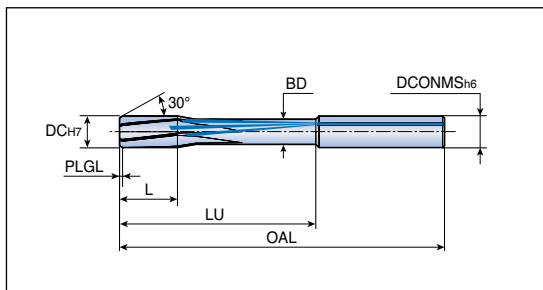

Обозначение	Размеры (мм)							NOF	Сплав ТТ5040
	DC	L	PLGL	BD	LU	OAL	DCONMS		
TS-L0300-NS *	3.0	12	0.7	2.2	31	60	4.0	4	●
L0400-NS	4.0	12	0.7	3.0	40	68	6.0	4	●
L0500-NS	5.0	12	0.9	3.8	40	76	6.0	4	●
L0600-NS	6.0	12	0.9	4.5	40	76	6.0	4	●
L0700-NS	7.0	15	0.9	5.6	65	101	8.0	6	●
L0800-NS	8.0	15	0.9	6.4	65	101	8.0	6	●
L0900-NS	9.0	18	0.95	7.2	61	101	10.0	6	●
L1000-NS	10.0	18	0.95	8.0	61	101	10.0	6	●
L1050-NS	10.5	18	1.05	8.4	85	130	12.0	6	●
L1100-NS	11.0	18	1.05	8.8	85	130	12.0	6	●
L1150-NS	11.5	18	1.05	9.2	85	130	12.0	6	●
L1200-NS	12.0	18	1.05	9.6	85	130	12.0	6	●



- Специальные диаметры доступны по запросу
- NOF: Число зубьев
- *: Развертки диаметром Ø3 мм без каналов СОЖ

●: Стандартная позиция

Прижимной ключ



Обозначение	Прижимной ключ	
	Диапазон диаметров головки (мм)	SSC
TM - B5-KEY	11.501-13.500	B5
B6-KEY	13.501-16.000	B6
B7-KEY	16.001-20.000	B7
B8-KEY	20.001-25.400	B8
B9-KEY	25.401-32.000	B9

• SSC : Размер кармана

TM...SCR

Прижимной винт

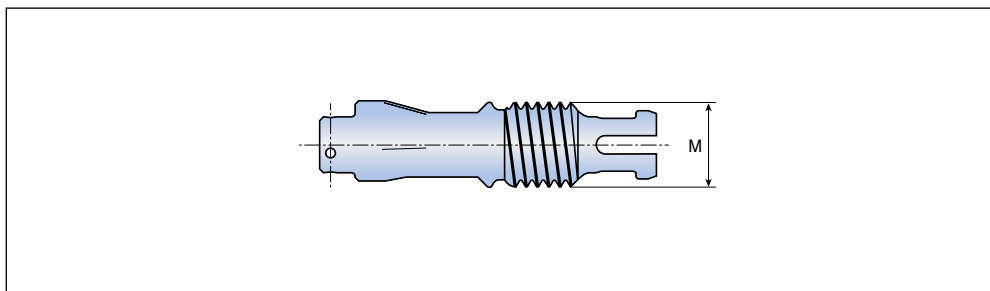

Обозначение	Прижимной винт	
	Диапазон диаметров головки (мм)	M
TM - B5-SCR	11.501-13.500	M5
B6-SCR	13.501-16.000	M6
B7-SCR	16.001-20.000	M7
B8-SCR	20.001-25.400	M8
B9-SCR	25.401-32.000	M9

Развертка со сменными лезвиями



• Для глухих отверстий

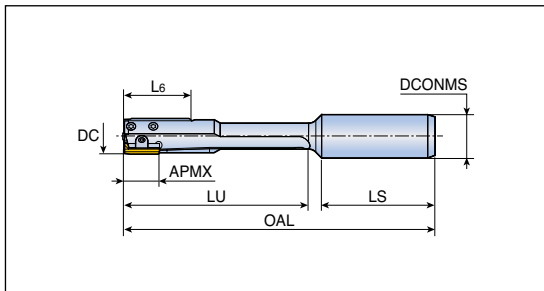

Обозначение	Размеры (мм)							SSC
	DC	APMX	OAL	LU	LS	L6	DCONMS	
TB-B08.000-S-16T0-1B	8	15.5	123.5	75	45	30	16	1
B09.000-S-16T0-1B	9	15.5	123.5	75	45	30	16	1
B10.000-S-16T0-2B	10	15.5	123.5	75	45	30	16	2
B11.000-S-16T0-2B	11	15.5	123.5	75	45	30	16	2
B12.000-S-16T0-3B	12	17.0	135	85	45	30	16	3
B13.000-S-16T0-3B	13	17.0	135	85	45	30	16	3
B14.000-S-16T0-3B	14	17.0	135	85	45	30	16	3
B15.000-S-16T0-3B	15	17.0	135	85	45	30	16	3
B16.000-S-20T0-3B	16	17.0	165	110	50	30	20	3
B17.000-S-20T0-3B	17	17.0	165	110	50	30	20	3
B18.000-S-20T0-3B	18	17.0	165	110	50	30	20	3
B19.000-S-20T0-3B	19	17.0	165	110	50	30	20	3
B20.000-S-25T0-3B	20	17.0	171	110	56	30	25	3
B21.000-S-25T0-3B	21	17.0	171	110	56	30	25	3
B22.000-S-25T0-3B	22	17.0	191	130	56	30	25	3
B23.000-S-25T0-3B	23	17.0	191	130	56	30	25	3
B24.000-S-25T0-3B	24	17.0	191	130	56	30	25	3
B25.000-S-25T0-3B	25	17.0	191	130	56	30	25	3
B26.000-S-25T0-4B	26	22.5	221	160	56	30	25	4
B27.000-S-25T0-4B	27	22.5	221	160	56	30	25	4
B28.000-S-25T0-4B	28	22.5	221	160	56	30	25	4
B29.000-S-25T0-4B	29	22.5	221	160	56	30	25	4
B30.000-S-25T0-4B	30	22.5	221	160	56	30	25	4
B31.000-S-25T0-4B	31	22.5	221	160	56	30	25	4
B32.000-S-25T0-4B	32	22.5	221	160	56	30	25	4

• SSC : Размер кармана

• Доступно по запросу



Сменные головки для развертывания

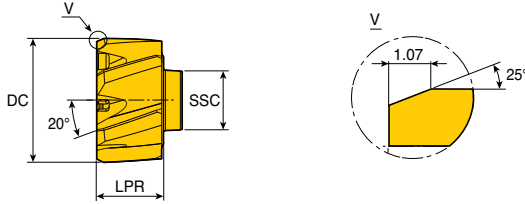

- Левосторонние зубья для сквозных отверстий
- Для допуска отверстия H7

Головка	Обозначение	Размеры (мм)		NOF	SSC	Тип зуба	Тип кромки	Сплав TT9030	
		DC	LPR						
	TM - 11.501-BL-B5	11.501	9.5	6	B5	L	B	●	
	12.000-BL-B5	12.000	9.5	6	B5	L	B	●	
	13.000-BL-B5	13.000	9.5	6	B5	L	B	●	
	13.500-BL-B5	13.500	9.5	6	B5	L	B	●	
	13.501-BL-B6	13.501	9.5	6	B6	L	B	●	
	14.000-BL-B6	14.000	9.5	6	B6	L	B	●	
	15.000-BL-B6	15.000	9.5	6	B6	L	B	●	
	16.000-BL-B6	16.000	9.5	6	B6	L	B	●	
	16.001-BL-B7	16.001	10.7	6	B7	L	B	●	
	17.000-BL-B7	17.000	10.7	6	B7	L	B	●	
	18.000-BL-B7	18.000	10.7	6	B7	L	B	●	
	19.000-BL-B7	19.000	10.7	6	B7	L	B	●	
	20.000-BL-B7	20.000	10.7	6	B7	L	B	●	
	20.001-BL-B8	20.001	12.9	8	B8	L	B	●	
	21.000-BL-B8	21.000	12.9	8	B8	L	B	●	
	22.000-BL-B8	22.000	12.9	8	B8	L	B	●	
	23.000-BL-B8	23.000	12.9	8	B8	L	B	●	
	24.000-BL-B8	24.000	12.9	8	B8	L	B	●	
	25.000-BL-B8	25.000	12.9	8	B8	L	B	●	
	26.000-BL-B9	26.000	12.9	8	B9	L	B	●	
	27.000-BL-B9	27.000	12.9	8	B9	L	B	●	
	28.000-BL-B9	28.000	12.9	8	B9	L	B	●	
	29.000-BL-B9	29.000	12.9	8	B9	L	B	●	
	30.000-BL-B9	30.000	12.9	8	B9	L	B	●	
	31.000-BL-B9	31.000	12.9	8	B9	L	B	●	
	32.000-BL-B9	32.000	12.9	8	B9	L	B	●	



- NOF: Число зубьев
- SSC : Размер кармана

●: Стандартная позиция

Сменные головки для развертывания

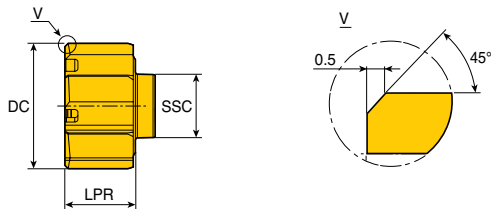

- Прямые зубья для сквозных отверстий
- Для допуска отверстия H7

Головка	Обозначение	Размеры (мм)		NOF	SSC	Тип зуба	Тип кромки	Сплав ТТ9030	
		DC	LPR						
	TM- 11.501-AS-B5	11.501	9.5	6	B5	S	A	●	
	12.000-AS-B5	12.000	9.5	6	B5	S	A	●	
	13.000-AS-B5	13.000	9.5	6	B5	S	A	●	
	13.500-AS-B5	13.500	9.5	6	B5	S	A	●	
	13.501-AS-B6	13.501	9.5	6	B6	S	A	●	
	14.000-AS-B6	14.000	9.5	6	B6	S	A	●	
	15.000-AS-B6	15.000	9.5	6	B6	S	A	●	
	16.000-AS-B6	16.000	9.5	6	B6	S	A	●	
	16.001-AS-B7	16.001	10.7	6	B7	S	A	●	
	17.000-AS-B7	17.000	10.7	6	B7	S	A	●	
	18.000-AS-B7	18.000	10.7	6	B7	S	A	●	
	19.000-AS-B7	19.000	10.7	6	B7	S	A	●	
	20.000-AS-B7	20.000	10.7	6	B7	S	A	●	
	20.001-AS-B8	20.001	12.9	8	B8	S	A	●	
	21.000-AS-B8	21.000	12.9	8	B8	S	A	●	
	22.000-AS-B8	22.000	12.9	8	B8	S	A	●	
	23.000-AS-B8	23.000	12.9	8	B8	S	A	●	
	24.000-AS-B8	24.000	12.9	8	B8	S	A	●	
	25.000-AS-B8	25.000	12.9	8	B8	S	A	●	
	26.000-AS-B9	26.000	12.9	8	B9	S	A	●	
	27.000-AS-B9	27.000	12.9	8	B9	S	A	●	
	28.000-AS-B9	28.000	12.9	8	B9	S	A	●	
	29.000-AS-B9	29.000	12.9	8	B9	S	A	●	
	30.000-AS-B9	30.000	12.9	8	B9	S	A	●	
	31.000-AS-B9	31.000	12.9	8	B9	S	A	●	
	32.000-AS-B9	32.000	12.9	8	B9	S	A	●	



- NOF: Число зубьев
- SSC : Размер кармана

●: Стандартная позиция

Сменные лезвия

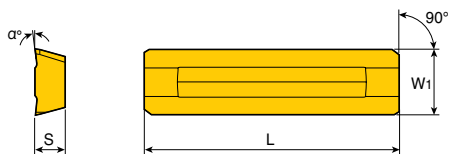

- Для допуска отверстия H6

Лезвие	Обозначение	Размеры (мм)				SSC	Тип лезвия	Сплавы	
		Передний угол (α°)	L	W ₁	S			TT5030	TT5050
	ТВ - 1B06	6	15.5	2.8	1.5	1	В	●	
	1B12	12	15.5	2.8	1.5	1	В	●	
	1A06	6	15.5	2.8	1.5	1	А		●
	1B06	6	15.5	2.8	1.5	1	В		●
	2B06	6	15.5	3.6	1.5	2	В	●	
	2B12	12	15.5	3.6	1.5	2	В	●	
	2A06	6	15.5	3.6	1.5	2	А		●
	2B06	6	15.5	3.6	1.5	2	В		●
	3B06	6	17.0	4.4	2.0	3	В	●	
	3B12	12	17.0	4.4	2.0	3	В	●	
	3A06	6	17.0	4.4	2.0	3	А		●
	3B06	6	17.0	4.4	2.0	3	В		●
	4B06	6	22.5	6.6	3.0	4	В	●	
	4B12	12	22.5	6.6	3.0	4	В	●	
	4A06	6	22.5	6.6	3.0	4	А		●
	4B06	6	22.5	6.6	3.0	4	В		●



- Применяемые сплавы
- TT5030: Покрытие TiAlN для стали (P) и нержавеющей стали (M) - TT5050: Покрытие TiCN + TiN для чугуна (K)
- SSC : Размер кармана

● : Стандартная позиция

Рекомендуемые условия резания

Режимы обработки для TS-REAM

ISO	Материал		Состояние		Предел прочности (Н/мм ²)	Твердость по Бринеллю	Материал №	Скорость резания Vc(м/мин)	Подача (мм/об)	
									Ø3-Ø10	Ø10.1-Ø12
P	Нелегированная сталь, литье, легкообрабатываемая сталь	<0.25%C	Отожженная							
		>=0.25%C	Отожженная	420	125	1	10-20	0.15-0.25	0.20-0.40	
		<0.55%C	Закалённая и отпущенная	650	190	2	6-15	0.12-0.15	0.15-0.30	
		>=0.55%C	Отожженная	850	250	3	6-20	0.15-0.25	0.20-0.35	
	Низколегированная сталь и литье (менее 5% легирующих добавок)	Закалённая и отпущенная	Отожженная	1000	300	5	6-15	0.15-0.25	0.20-0.35	
			Закалённая и отпущенная	600	200	6	6-15	0.12-0.20	0.15-0.30	
		Отожженная	Закалённая и отпущенная	930	275	7	6-20	0.15-0.25	0.20-0.35	
			Отожженная	1000	300	8	6-15	0.15-0.25	0.20-0.35	
		Высоколегированная сталь, литье и инструментальная сталь	Отожженная	1200	350	9	6-15	0.15-0.25	0.20-0.35	
			Закалённая и отпущенная	680	200	10	6-15	0.12-0.20	0.15-0.30	
M	Нержавеющая сталь и литье	Ферритная/Мартенситная	1100	325	11	6-15	0.12-0.20	0.15-0.30		
		Мартенситная	680	200	12					
		Аустенитная	820	240	13					
K	Серый чугун (GG)	Ферритный	600	180	14					
		Перлитный		160	15	10-25	0.20-0.30	0.30-0.45		
	Чугун с шаровидным графитом (GGG)	Ферритный		250	16	10-25	0.20-0.30	0.30-0.45		
		Перлитный		180	17	10-20	0.15-0.25	0.20-0.35		
	Ковкий чугун	Ферритный		260	18	10-20	0.15-0.25	0.20-0.35		
N	Деформируемые алюминиевые сплавы	Неструктурированные		230	20	8-15	0.15-0.25	0.20-0.40		
		Структурированные		60	21	10-30	0.20-0.30	0.30-0.50		
	Алюминий - литье, легированный сплав	<=12% Si	Неструктурированные		100	22	10-30	0.20-0.30	0.30-0.50	
		>12% Si	Структурированные		75	23	10-30	0.20-0.30	0.30-0.50	
		>1% Pb	Жаропрочные сплавы		90	24	10-30	0.20-0.30	0.30-0.50	
	Сплавы меди	Легкообрабатываемые		130	25	30-60	0.20-0.30	0.30-0.50		
		Латунь		110	26	20-60	0.30-0.60	0.40-0.80		
		Электролитная медь		90	27	20-60	0.30-0.60	0.40-0.80		
	Неметаллические материалы	Реактопласты, волокниты		100	28	20-60	0.30-0.60	0.40-0.80		
		Твердая резина			29	15-30	0.30-0.60	0.40-0.80		
S	Жаропрочные сплавы	На основе железа	Отожженная			30	15-30	0.30-0.60	0.40-0.80	
		Структурированные		200	31					
		На основе никеля или кобальта	Отожженная		280	32				
		Структурированные		250	33					
	Литье		350	34						
Титан, титановые сплавы	Альфа и бета сплавы структурированные	Rm 400		36	6-15	0.12-0.20	0.15-0.30			
H	Закаленная сталь	Закалка	Rm 1050		37	6-15	0.12-0.20	0.15-0.30		
		Закалка		55HRC	38					
	Отбеленный чугун	Литье		60HRC	39					
	Чугун с шаровидным графитом	Закалка		400	40					
Cast iron nodular	Hardened			55HRC	41					

• Подробную информацию по группам материалов см. в Техническом Руководстве, "Таблица соответствия материалов"

■ Сталь
 ■ Нержавеющая сталь
 ■ Чугун
 ■ Цветные металлы
 ■ Жаропрочные сплавы
 ■ Закаленная сталь

Рекомендуемые условия резания



Режимы обработки для TM-REAM - Сквозное отверстие

ISO	Материал	Состояние	Материал №	Сквозное отверстие		Сквозное отверстие, прерывистое резание		
P	Нелегированная сталь, литье, легкообрабатываемая сталь	<0.25%C	Отожженная	1	TT9030	BL	TT9030	BL
		>=0.25%C	Отожженная	2	Vc = 80 - 200		Vc = 60 - 120	
		<0.55%C	Закалённая и отпущенная	3	B4 - B6	fz = 0.08 - 0.21	B4 - B6	fz = 0.08 - 0.21
		>=0.55%C	Отожженная	4	B7 - B9	fz = 0.12 - 0.27	B7 - B9	fz = 0.09 - 0.21
		Закалённая и отпущенная	5	B7 - B9		fz = 0.12 - 0.27	B7 - B9	fz = 0.09 - 0.21
	Низколегированная сталь и литье (менее 5% легирующих добавок)		Отожженная	6	TT9030	BL	TT9030	BL
			Закалённая и отпущенная	7	Vc = 80 - 200		Vc = 60 - 120	
				8	B4 - B6	fz = 0.08 - 0.21	B4 - B6	fz = 0.08 - 0.21
	Высоколегированная сталь, литье и инструментальная сталь		Отожженная	9	B7 - B9	fz = 0.12 - 0.27	B7 - B9	fz = 0.09 - 0.21
				10	TT9030	BL	TT9030	BL
			Закалённая и отпущенная		Vc = 20 - 60		Vc = 20 - 60	
		11		B4 - B6	fz = 0.05 - 0.13	B4 - B6	fz = 0.04 - 0.11	
M	Нержавеющая сталь и литье	Ферритная/Мартенситная	12	TT9030	BL	TT9030	BL	
				Vc = 20 - 40		Vc = 20 - 40		
		Мартенситная	13	B4 - B6	fz = 0.05 - 0.13	B4 - B6	fz = 0.04 - 0.11	
	Аустенитная	14	B7 - B9	fz = 0.07 - 0.17	B7 - B9	fz = 0.05 - 0.14		
K	Серый чугун (GG)	Ферритный	15	TT9030	BL	TT9030	BL	
				Vc = 120 - 220		Vc = 80 - 200		
	Перлитный	16	B4 - B6	fz = 0.08 - 0.18	B4 - B6	fz = 0.05 - 0.13		
			B7 - B9	fz = 0.10 - 0.24	B7 - B9	fz = 0.07 - 0.17		
	Чугун с шаровидным графитом (GGG)	Ферритный	17	TT9030	AS or BL	TT9030	BL	
				Vc = 160 - 280		Vc = 150 - 250		
	Перлитный	18	B4 - B6	fz = 0.11 - 0.20	B4 - B6	fz = 0.06 - 0.15		
			B7 - B9	fz = 0.11 - 0.24	B7 - B9	fz = 0.08 - 0.19		
Ковкий чугун	Ферритный	19	TT9030	AS or BL	TT9030	BL		
				Vc = 100 - 220		Vc = 100 - 220		
	Перлитный	20	B4 - B6	fz = 0.11 - 0.20	B4 - B6	fz = 0.06 - 0.15		
		B7 - B9	fz = 0.11 - 0.24	B7 - B9	fz = 0.08 - 0.20			

• Подробную информацию по группам материалов см. в Техническом Руководстве, "Таблица соответствия материалов"

■ Сталь
 ■ Нержавеющая сталь
 ■ Чугун
 ■ Цветные металлы
 ■ Жаропрочные сплавы
 ■ Закаленная сталь

Рекомендуемые условия резания



Режимы обработки для TM-REAM - Сквозное отверстие

ISO	Материал	Состояние	Материал №	Сквозное отверстие		Сквозное отверстие, прерывистое резание		
N	Деформируемые алюминиевые сплавы	Неструктурированные	21	B7 - B9	BL or GS	TTAL10	BL	
		Структурированные	22	Vc = 150 - 400		Vc = 150 - 400		
	Алюминий - литье, легированный сплав	<=12% Si	Неструктурированные	23	B4 - B6	fz = 0.08 - 0.16	B4 - B6	fz = 0.08 - 0.16
		Структурированные	24					
	Сплавы меди	>12% Si	Жаропрочные сплавы	25	B7 - B9	fz = 0.10 - 0.20	B7 - B9	fz = 0.10 - 0.20
			Легкообрабатываемые	26	TT9030	BL	TT9030	BL
		Латунь	27	B4 - B6	fz = 0.08 - 0.18	B4 - B6	fz = 0.05 - 0.13	
	Неметаллические материалы	Электродлитная медь	Реактопласты, волокниты	29	TT9030	AS	TT9030	AS
				Vc = 25 - 80		Vc = 25 - 80		
		Твердая резина	30	B4 - B6	fz = 0.05 - 0.10	B4 - B6	fz = 0.05 - 0.10	
B7 - B9				fz = 0.10 - 0.20	B7 - B9	fz = 0.10 - 0.20		
S	Жаропрочные сплавы	На основе железа	Отожженная	31	TT9030	L *	TT9030	L *
		На основе никеля или кобальта	Структурированные	32	Vc = 15 - 50		Vc = 15 - 50	
			Отожженная	33	B4 - B6	fz = 0.04 - 0.10	B4 - B6	fz = 0.03 - 0.08
			Структурированные	34				
	Литье	35						
	Титан, титановые сплавы	Альфа и бета сплавы структурированные	36	B7 - B9	fz = 0.05 - 0.13	B4 - B6	fz = 0.04 - 0.11	
37								
H	Закаленная сталь	Закалка	38	TT9030	BL	TT9030	BL	
		Закалка	39	Vc = 25 - 50		Vc = 25 - 50		
	Отбеленный чугун	Литье	40	B4 - B6	fz = 0.06 - 0.15	B4 - B6	fz = 0.06 - 0.15	
	Чугун с шаровидным графитом	Закалка	41	B7 - B9	fz = 0.10 - 0.20	B7 - B9	fz = 0.10 - 0.20	

* Стандартная геометрия режущей кромки не подходит для обработки титана и жаропрочных сплавов.

Для того, чтобы выбрать необходимую геометрию, пожалуйста, обратитесь за нашими рекомендациями

- Данные рекомендуемые режимы резания относятся к коротким державкам (с вылетом 3xD) Для державок с большим вылетом скорость резания должна быть уменьшена пропорционально.
- Для относительно больших углов в плане (геометрия цековки) подачу необходимо уменьшить до 30%.
- Все данные режимы резания относятся к станкам с подачей СОЖ через шпиндель.

Обозначения:

Сплав	→	TT9030	BL	←	Геометрия головки
Скорость резания (м/мм)	→	Vc = 10 - 20		←	Подача (мм/зуб)
Размер головки TM-REAM	→	B4-B6	fz = 0.04 - 0.15	←	
	→	B7-B9	fz = 0.05 - 0.20	←	

Рекомендуемые условия резания



Режимы обработки для TM-REAM - Глухое отверстие

ISO	Материал	Состояние	Материал №	Глухое отверстие		Глухое отверстие прерывистое резание		
P	Нелегированная сталь, литье, легкообрабатываемая сталь	<0.25%C	Отожженная	1	TT9030	AS	TT9030	AS
		>=0.25%C	Отожженная	2	Vc = 60-160		Vc = 60 - 120	
		<0.55%C	Закалённая и отпущенная	3	B4 - B6	fz = 0.06 - 0.18	B4 - B6	fz = 0.05 - 0.15
		>=0.55%C	Отожженная	4				
	Низколегированная сталь и литье (менее 5% легирующих добавок)	Закалённая и отпущенная	Отожженная	6	TT9030	AS	TT9030	AS
			Закалённая и отпущенная	7	Vc = 60-160		Vc = 60 - 120	
				8	B4 - B6	fz = 0.06 - 0.18	B4 - B6	fz = 0.05 - 0.15
	Высоколегированная сталь, литье и инструментальная сталь	Закалённая и отпущенная	Закалённая и отпущенная	9	B7 - B9	fz = 0.08 - 0.20	B7 - B9	fz = 0.07 - 0.16
				10	TT9030	AS	TT9030	AS
			11	Vc = 20 - 60		Vc = 20 - 60		
	M	Нержавеющая сталь и литье	Ферритная/Мартенситная	12	TT9030	AS	TT9030	AS
Мартенситная			13	Vc = 20 - 40		Vc = 20 - 40		
			14	B4 - B6	fz = 0.04 - 0.10	B4 - B6	fz = 0.03 - 0.08	
K	Серый чугун (GG)	Ферритный	15	B7 - B9	fz = 0.05 - 0.13	B7 - B9	fz = 0.05 - 0.10	
		Перлитный	16	TT9030	AS	TT9030	AS	
	Чугун с шаровидным графитом (GGG)	Ферритный	17	Vc = 80 - 200		Vc = 60 - 120		
		Перлитный	18	B4 - B6	fz = 0.06 - 0.18	B4 - B6	fz = 0.05 - 0.13	
	Ковкий чугун	Ферритный	19	B7 - B9	fz = 0.08 - 0.23	B7 - B9	fz = 0.08 - 0.18	
			20	TT9030	AS	TT9030	AS	
		Перлитный	20	Vc = 100 - 220		Vc = 100 - 220		
			Перлитный	20	B4 - B6	fz = 0.06 - 0.18	B4 - B6	fz = 0.06 - 0.16
		Перлитный	20	B7 - B9	fz = 0.08 - 0.23	B7 - B9	fz = 0.08 - 0.18	
		Перлитный	20	B4 - B6	fz = 0.06 - 0.18	B4 - B6	fz = 0.05 - 0.15	
		Перлитный	20	B7 - B9	fz = 0.08 - 0.23	B7 - B9	fz = 0.08 - 0.20	

• Подробную информацию по группам материалов см. в Техническом Руководстве, "Таблица соответствия материалов"

■ Сталь
 ■ Нержавеющая сталь
 ■ Чугун
 ■ Цветные металлы
 ■ Жаропрочные сплавы
 ■ Закаленная сталь

Рекомендуемые условия резания



Режимы обработки для TM-REAM - Глухое отверстие

ISO	Материал	Состояние	Материал №	Глухое отверстие		Глухое отверстие прерывистое резание		
N	Деформируемые алюминиевые сплавы	Неструктурированные	21	TTAL10	GS or AS	TTAL10	GS or AS	
		Структурированные	22	Vc = 150 - 400		Vc = 150 - 300		
	Алюминий - литье, легированный сплав	<=12% Si	Неструктурированные	23	B4 - B6	fz = 0.08 - 0.16	B4 - B6	fz = 0.07 - 0.15
		Структурированные	24					
	Сплавы меди	>12% Si	Жаропрочные сплавы	25	B7 - B9	fz = 0.11 - 0.20	B7 - B9	fz = 0.11 - 0.20
		>1% Pb	Легкообрабатываемые	26	TT9030	AS	TT9030	AS
	Неметаллические материалы	Латунь	Электродлитная медь	27	B4 - B6	fz = 0.08 - 0.16	B4 - B6	fz = 0.08 - 0.16
					B7 - B9	fz = 0.10 - 0.20	B7 - B9	fz = 0.10 - 0.20
		Реактопласты, волокниты	Твердая резина	29	TT9030	AS	TT9030	AS
					Vc = 25 - 80		Vc = 25 - 80	
S	Жаропрочные сплавы	На основе железа	Отожженная	31	TT9030	L *	TT9030	L *
		На основе никеля или кобальта	Структурированные	32	Vc = 15 - 50		Vc = 15 - 50	
			Отожженная	33	B4 - B6	fz = 0.03 - 0.08	B4 - B6	fz = 0.03 - 0.08
			Структурированные	34				
	Литье	35						
Титан, титановые сплавы	Альфа и бета сплавы структурированные	36	B7 - B9	fz = 0.04 - 0.11	B7 - B9	fz = 0.04 - 0.11		
		37						
H	Закаленная сталь	Закалка	38	TT9030	AS	TT9030	AS	
		Закалка	39	Vc = 25 - 50		Vc = 25 - 50		
	Отбеленный чугун	Литье	40	B4 - B6	fz = 0.05 - 0.13	B4 - B6	fz = 0.05 - 0.13	
	Чугун с шаровидным графитом	Закалка	41	B7 - B9	fz = 0.10 - 0.20	B7 - B9	fz = 0.10 - 0.20	

* Стандартная геометрия режущей кромки не подходит для обработки титана и жаропрочных сплавов.

Для того, чтобы выбрать необходимую геометрию, пожалуйста, обратитесь за нашими рекомендациями.

- Данные рекомендуемые режимы резания относятся к коротким державкам (с вылетом 3xD) Для державок с большим вылетом скорость резания должна быть уменьшена пропорционально.
- Для относительно больших углов в плане (геометрия цековки) подачу необходимо уменьшить до 30%.
- Все данные режимы резания относятся к станкам с подачей СОЖ через шпиндель.

Обозначения:

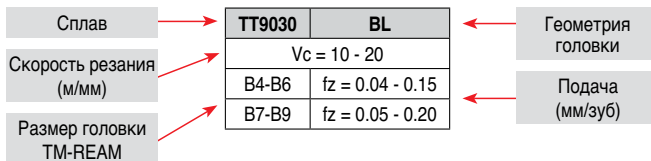

Рекомендуемые условия резания



Режимы обработки для TB-REAM

			Угол в плане A (15°/3°) (Допуск развертки: 0.1 ~ 0.3)						
			Подача (мм/об)	Передний угол (°)	Скорость резания Vc (м/мин)				
ISO	Материал	Материал №			Твердый сплав	Твердый сплав с покрытием	Кермет	PCD	CBN
P	Нелегированная сталь, литье, легкообрабатываемая сталь	1 - 5	0.1-0.4	6	40-60	60-80	110-160		
	Низколегированная сталь и литье (менее 5% легирующих добавок)	6 - 9	0.1-0.4	6	20-40	40-60	110-160		
	Высоколегированная сталь, литье и инструментальная сталь	10 - 11	0.1-0.4	6	20-40	20-60	20-60		
M	Нержавеющая сталь и литье	12 - 14	0.1-0.3	12	20-40	40-60	20-60		
K	Серый чугун (GG)	15 - 16	0.1-0.3	0 / 6	40-60	60-100			По запросу
	Чугун с шаровидным графитом (GGG)	17 - 18	0.1-0.3	0 / 6	40-60	60-100			
	Ковкий чугун	19 - 20	0.1-0.3	0 / 6	40-60	60-100			
N	Деформируемые алюминиевые сплавы	21 - 22						По запросу	
	Алюминий - литье, легированный сплав	23 - 25							
	Сплавы меди	26 - 28							
	Неметаллические материалы	29 - 30							

			Угол в плане C (75°) (Допуск развертки: 0.2~ 0.4)						
			Подача (мм/об)	Передний угол (°)	Скорость резания Vc (м/мин)				
ISO	Материал	Материал №			Твердый сплав	Твердый сплав с покрытием	Кермет	PCD	CBN
P	Нелегированная сталь, литье, легкообрабатываемая сталь	1 - 5							
	Низколегированная сталь и литье (менее 5% легирующих добавок)	6 - 9							
	Высоколегированная сталь, литье и инструментальная сталь	10 - 11							
M	Нержавеющая сталь и литье	12 - 14							
K	Серый чугун (GG)	15 - 16							По запросу
	Чугун с шаровидным графитом (GGG)	17 - 18							
	Ковкий чугун	19 - 20							
N	Деформируемые алюминиевые сплавы	21 - 22	0.15-0.3	12	150-250			По запросу	
	Алюминий - литье, легированный сплав	23 - 25	0.15-0.3	12	150-250				
	Сплавы меди	26 - 28							
	Неметаллические материалы	29 - 30							

• Режимы резания, приведенные ниже в таблице, должны применяться в случае первого использования инструмента. Оптимальные режимы для специфических операций должны выбираться после проверки результатов и соответствующего изменения условий обработки.

• Подробную информацию по группам материалов см. в Техническом Руководстве, "Таблица соответствия материалов"

■ Сталь
 ■ Нержавеющая сталь
 ■ Чугун
 ■ Цветные металлы

Рекомендуемые условия резания



Режимы обработки для TB-REAM

			Угол в плане В (30°/3°) (Допуск развертки: 0.1 ~ 0.3)						
			Подача (мм/об)	Передний угол (°)	Скорость резания V _c (м/мин)				
ISO	Материал	Материал №			Твердый сплав	Твердый сплав с покрытием	Кермет		
P	Нелегированная сталь, литье, легкообрабатываемая сталь	1 - 5	0.1-0.4	6	60-80	80-120	110-160		
	Низколегированная сталь и литье (менее 5% легирующих добавок)	6 - 9	0.1-0.4	6	60-80	80-120	110-160		
	Высоколегированная сталь, литье и инструментальная сталь	10 - 11	0.1-0.4	6	40-60	40-80	40-80		
M	Нержавеющая сталь и литье	12 - 14	0.1-0.3	12	40-60	60-80	60-80		
K	Серый чугун (GG)	15 - 16	0.1-0.3	0 / 6	60-80	80-120			По запросу
	Чугун с шаровидным графитом (GGG)	17 - 18	0.1-0.3	0 / 6	60-80	80-120			
	Ковкий чугун	19 - 20	0.1-0.3	0 / 6	60-80	80-120			
N	Деформируемые алюминиевые сплавы	21 - 22		12	160-200			По запросу	
	Алюминий - литье, легированный сплав	23 - 25		12	160-200				
	Сплавы меди	26 - 28		0	80-100				
	Неметаллические материалы	29 - 30		0	10-70				

			Угол в плане D (30°/3°) (Допуск развертки: 0.1 ~ 0.2)						
			Подача (мм/об)	Передний угол (°)	Скорость резания V _c (м/мин)				
ISO	Материал	Материал №			Твердый сплав	Твердый сплав с покрытием	Кермет		
P	Нелегированная сталь, литье, легкообрабатываемая сталь	1 - 5	0.1-0.4	6	60-80	80-120	110-160		
	Низколегированная сталь и литье (менее 5% легирующих добавок)	6 - 9	0.1-0.4	6	60-80	80-120	110-160		
	Высоколегированная сталь, литье и инструментальная сталь	10 - 11	0.1-0.4	6	40-60	40-80	40-80		
M	Нержавеющая сталь и литье	12 - 14	0.1-0.3	12	40-60	60-80	60-80		
K	Серый чугун (GG)	15 - 16	0.1-0.3	0 / 6	60-80	80-120			По запросу
	Чугун с шаровидным графитом (GGG)	17 - 18	0.1-0.3	0 / 6	60-80	80-120			
	Ковкий чугун	19 - 20	0.1-0.3	0 / 6	60-80	80-120			
N	Деформируемые алюминиевые сплавы	21 - 22		12	110-200			По запросу	
	Алюминий - литье, легированный сплав	23 - 25		12	160-200				
	Сплавы меди	26 - 28		0	80-100				
	Неметаллические материалы	29 - 30							

• Режимы резания, приведенные ниже в таблице, должны применяться в случае первого использования инструмента. Оптимальные режимы для специфических операций должны выбираться после проверки результатов и соответствующего изменения условий обработки.

• Подробную информацию по группам материалов см. в Техническом Руководстве, "Таблица соответствия материалов"

■ Сталь
 ■ Нержавеющая сталь
 ■ Чугун
 ■ Цветные металлы

▶ Насадки для обработки фаски - DRILL-RUSH

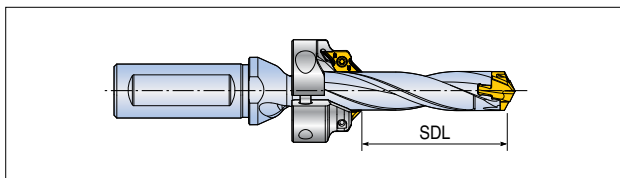

	Обозначение	CFR Обозначение	SDL	
			min	max
3D	TCD 130-134-16T3/S0-3D	CFR D130-A45	19	19
	135-139-16T3/S0-3D	CFR D135-A45	19	20
	140-144-16T3/S0-3D	CFR D140-A45	21	22
	145-149-16T3/S0-3D	CFR D145-A45	22	23
	150-159-20T3/S0-3D	CFR D150-A45	23	23
	160-169-20T3/S0-3D	CFR D160-A45	24	25
	170-179-20T3/S0-3D	CFR D170-A45	26	28
	180-189-25T2/S0-3D	CFR D180-A45	27	30
	190-199-25T2/S0-3D	CFR D190-A45	29	33
	200-209-25T2/S0-3D	CFR D200-A45	30	36
	210-219-25T2/S0-3D	CFR D210-A45	32	39
	220-229-25T2/S0-3D	CFR D220-A45	33	42
	230-239-32T2/S0-3D	CFR D230-A45	35	45
240-249-32T2/S0-3D	CFR D240-A45	36	48	
250-259-32T2/S0-3D	CFR D250-A45	38	51	
5D	TCD 100-104-16T3/S0-5D	CFR D100-A45	28	28
	105-109-16T3/S0-5D	CFR D105-A45	29	30
	110-114-16T3/S0-5D	CFR D110-A45	31	33
	115-119-16T3/S0-5D	CFR D115-A45	32	35
	120-124-16T3/S0-5D	CFR D120-A45	33	45
	125-129-16T3/S0-5D	CFR D125-A45	34	40
	130-134-16T3/S0-5D	CFR D130-A45	36	43
	135-139-16T3/S0-5D	CFR D135-A45	37	43
	140-144-16T3/S0-5D	CFR D140-A45	38	48
	145-149-16T3/S0-5D	CFR D145-A45	39	48
	150-159-20T3/S0-5D	CFR D150-A45	41	53
	160-169-20T3/S0-5D	CFR D160-A45	43	58
	170-179-20T3/S0-5D	CFR D170-A45	46	63
	180-189-25T2/S0-5D	CFR D180-A45	48	68
	190-199-25T2/S0-5D	CFR D190-A45	51	73
	200-209-25T2/S0-5D	CFR D200-A45	53	78
	210-219-25T2/S0-5D	CFR D210-A45	56	79
	220-229-25T2/S0-5D	CFR D220-A45	58	84
230-239-32T2/S0-5D	CFR D230-A45	61	89	
240-249-32T2/S0-5D	CFR D240-A45	63	94	
250-259-32T2/S0-5D	CFR D250-A45	66	99	

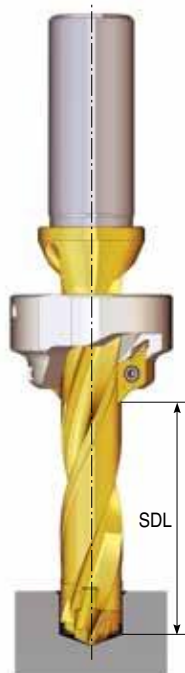

▶ Насадки для обработки фаски - DRILL-RUSH

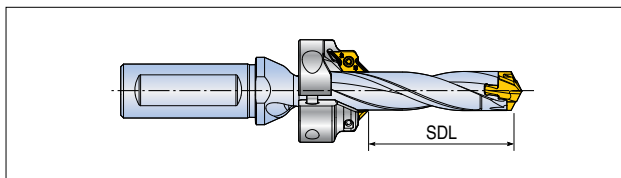

	Обозначение	CFR Обозначение	SDL	
			min	max
8D	TCD 100-104-16T3/S0-8D	CFR D100-A45	45	58
	105-109-16T3/S0-8D	CFR D105-A45	49	62
	110-114-16T3/S0-8D	CFR D110-A45	49	66
	115-119-16T3/S0-8D	CFR D115-A45	53	70
	120-124-16T3/S0-8D	CFR D120-A45	53	74
	125-129-16T3/S0-8D	CFR D125-A45	57	78
	130-134-16T3/S0-8D	CFR D130-A45	57	82
	135-139-16T3/S0-8D	CFR D135-A45	61	84
	140-144-16T3/S0-8D	CFR D140-A45	61	88
	145-149-16T3/S0-8D	CFR D145-A45	65	92
	150-159-20T3/S0-8D	CFR D150-A45	65	96
	160-169-20T3/S0-8D	CFR D160-A45	69	103
	170-179-20T3/S0-8D	CFR D170-A45	73	111
	180-189-25T2/S0-8D	CFR D180-A45	77	118
	190-199-25T2/S0-8D	CFR D190-A45	81	126
	200-209-25T2/S0-8D	CFR D200-A45	85	134
	210-219-25T2/S0-8D	CFR D210-A45	89	142
220-229-25T2/S0-8D	CFR D220-A45	93	150	
230-239-32T2/S0-8D	CFR D230-A45	97	158	
240-249-32T2/S0-8D	CFR D240-A45	101	166	
250-259-32T2/S0-8D	CFR D250-A45	105	174	
12D	TCD 120-124-16S0-12D	CFR D120-A45	87	121
	125-129-16S0-12D	CFR D125-A45	90	127
	130-134-16S0-12D	CFR D130-A45	93	133
	135-139-16S0-12D	CFR D135-A45	96	137
	140-144-16S0-12D	CFR D140-A45	99	143
	145-149-16S0-12D	CFR D145-A45	102	149
	150-159-20S0-12D	CFR D150-A45	105	155
	160-169-20S0-12D	CFR D160-A45	111	166
	170-179-20S0-12D	CFR D170-A45	117	178
	180-189-25S0-12D	CFR D180-A45	123	189
	190-199-25S0-12D	CFR D190-A45	129	201
	200-209-25S0-12D	CFR D200-A45	135	213
	210-219-25S0-12D	CFR D210-A45	141	225
220-229-25S0-12D	CFR D220-A45	147	237	

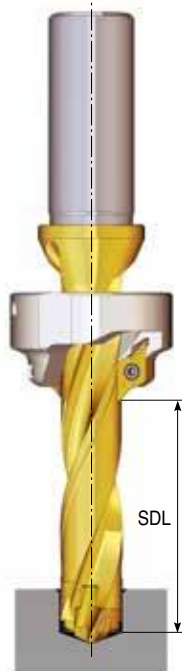

▶ Насадки для обработки фасок - TOP-DRILL и T-DRILL

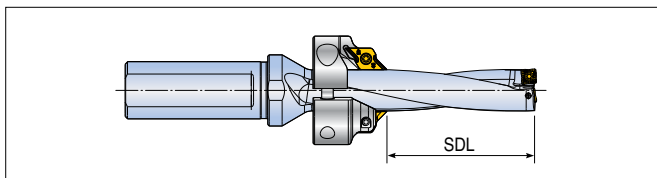

	TOP-DRILL	T-DRILL	CFR Обозначение	SDL	
				min	max
3D	TOP -	TDR 3125-20T2-05	CFR D125-A45	16	16
	-	3130-20T2-05	CFR D130-A45	16	16
	-	3135-20T2-05	CFR D135-A45	17	18
	3140-20T2-05	3140-20T2-05	CFR D140-A45	17	18
	3145-20T2-05	3145-20T2-05	CFR D145-A45	18	19
	3150-20T2-05	3150-20T2-05	CFR D150-A45	18	19
	3155-20T2-05	3155-25T2-06	CFR D160-A45	19	21
	3160-20T2-05	3160-25T2-06	CFR D160-A45	19	21
	3165-25T2-06	3165-25T2-06	CFR D170-A45	21	24
	3170-25T2-06	3170-25T2-06	CFR D170-A45	22	24
	3175-25T2-06	3175-25T2-06	CFR D180-A45	23	27
	3180-25T2-06	3180-25T2-06	CFR D180-A45	23	26
	3185-25T2-06	3185-25T2-06	CFR D180-A45	24	29
	3190-25T2-06	3190-25T2-06	CFR D190-A45	25	29
	3195-25T2-07	3195-25T2-06	CFR D190-A45	25	32
	3200-25T2-07	3200-25T2-06	CFR D200-A45	26	32
	3205-25T2-07	3205-25T2-06	CFR D200-A45	27	35
	3210-25T2-07	3210-25T2-06	CFR D210-A45	27	35
	3215-25T2-07	3215-25T2-07	CFR D210-A45	28	38
	3220-25T2-07	3220-25T2-07	CFR D220-A45	29	38
	3225-25T2-08	3225-25T2-07	CFR D220-A45	29	41
	3230-25T2-08	3230-25T2-07	CFR D230-A45	30	41
	3235-25T2-08	3235-25T2-07	CFR D230-A45	31	44
	3240-25T2-08	3240-25T2-07	CFR D240-A45	31	44
	3245-25T2-08	3245-25T2-07	CFR D240-A45	32	47
	3250-25T2-08	3250-25T2-07	CFR D250-A45	33	47



▶ Насадки для обработки фасок - TOP-DRILL и T-DRILL

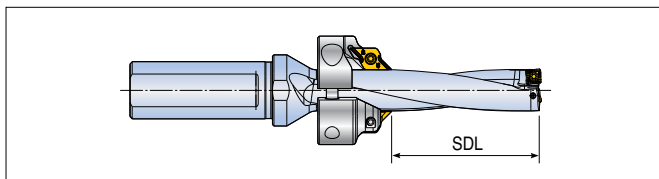

	TOP-DRILL	T-DRILL	CFR Обозначение	SDL	
				min	max
4D	TOP -	TDR 4125-20T2-05	CFR D125-A45	25	26
	-	4130-20T2-05	CFR D130-A45	25	26
	-	4135-20T2-05	CFR D135-A45	27	30
	4140-20T2-05	4140-20T2-05	CFR D140-A45	28	30
	4145-20T2-05	4145-20T2-05	CFR D145-A45	29	34
	4150-20T2-05	4150-20T2-05	CFR D150-A45	30	34
	4155-20T2-05	4155-25T2-06	CFR D160-A45	31	37
	4160-20T2-05	4160-25T2-06	CFR D160-A45	32	37
	4165-25T2-06	4165-25T2-06	CFR D170-A45	33	41
	4170-25T2-06	4170-25T2-06	CFR D170-A45	34	41
	4175-25T2-06	4175-25T2-06	CFR D180-A45	35	45
	4180-25T2-06	4180-25T2-06	CFR D180-A45	36	44
	4185-25T2-06	4185-25T2-06	CFR D180-A45	37	48
	4190-25T2-06	4190-25T2-06	CFR D190-A45	38	48
	4195-25T2-07	4195-25T2-06	CFR D190-A45	39	52
	4200-25T2-07	4200-25T2-06	CFR D200-A45	40	52
	4205-25T2-07	4205-25T2-06	CFR D200-A45	41	56
	4210-25T2-07	4210-25T2-06	CFR D210-A45	42	56
	4215-25T2-07	4215-25T2-07	CFR D210-A45	43	60
	4220-25T2-07	4220-25T2-07	CFR D220-A45	44	60
	4225-25T2-08	4225-25T2-07	CFR D220-A45	45	64
	4230-25T2-08	4230-25T2-07	CFR D230-A45	46	64
	4235-25T2-08	4235-25T2-07	CFR D230-A45	47	68
	4240-25T2-08	4240-25T2-07	CFR D240-A45	48	68
	4245-25T2-08	4245-25T2-07	CFR D240-A45	49	72
4250-25T2-08	4250-25T2-07	CFR D250-A45	50	72	



► Руководство по замене модульной головки

1. Снимите обе наружные пластины, затем снимите центральную сверлильную головку. (При сборке действуйте в обратном порядке)



2. Используйте ключ, чтобы повернуть винт против часовой стрелки, чтобы снять модульную головку.

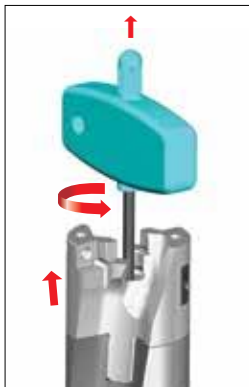

3. Установите калибровочный шаблон на нижнюю часть отсоединенной модульной головки.



4. Проверьте винт, чтобы отрегулировать такую же высоту с помощью калибровочного шаблона.

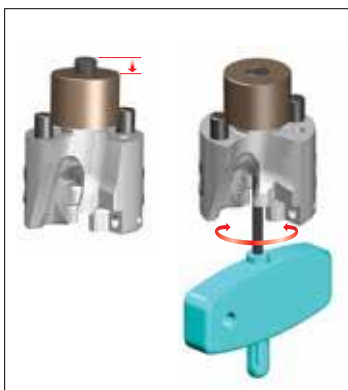

Калибровочный шаблон

Диаметр сверла	Обозначение
D26-D29	SG TNDH D26-29-TP
D30-D35	SG TNDH D30-35-TP
D36-D39	SG TNDH D36-39-TP
D40-D43	SG TNDH D40-43-TP
D44-D50	SG TNDH D44-50-TP

5. Снимите модульную головку, настроенную по высоте с калибровочного шаблона и установите ее на корпус инструмента.

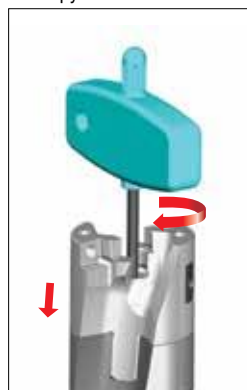

► Разбор модульной головки в случае повреждения центрального сверла

Если крепление модульной головки невозможно разжать из-за повреждения центрального сверла, вставьте ключ в заднюю часть хвостовика. Поверните ключ по часовой стрелке, чтобы разобрать модульную головку.

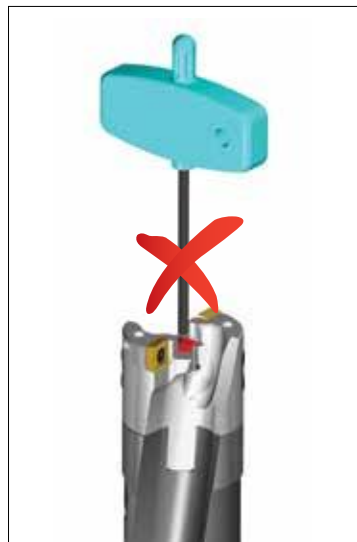

Поврежденное
центральное сверло



- Разбор модульной головки в случае повреждения центрального сверла (MDB Dxx/xx...)

Технические данные

► Допуск отверстия

Диаметр D(мм)		Допуск (μm)															
>D	≤D	B10	C9	C10	D8	D9	D10	E7	E8	E9	F6	F7	F8	G6	G7	H6	H7
-	3	+180 +140	+85 +60	+100 +60	+34 +20	+45 +20	+60 +20	+24 +14	+28 +14	+39 +14	+12 +6	+16 +6	+20 +6	+8 +2	+12 +2	+6 0	+10 0
3	6	+180 +140	+100 +70	+118 +70	+48 +30	+60 +30	+78 +30	+32 +20	+38 +20	+50 +20	+18 +10	+22 +10	+28 +10	+12 +4	+16 +4	+8 0	+12 0
6	10	+208 +150	+116 +80	+138 +80	+62 +40	+76 +40	+98 +40	+40 +25	+47 +25	+61 +25	+22 +13	+28 +13	+35 +13	+14 +5	+20 +5	+9 0	+15 0
10	14	+220 +150	+138 +95	+165 +95	+77 +50	+93 +50	+120 +50	+50 +32	+59 +32	+75 +32	+27 +16	+34 +16	+43 +16	+17 +6	+24 +6	+11 0	+18 0
14	18																
18	24	+244 +160	+162 +110	+194 +110	+98 +65	+117 +65	+149 +65	+61 +40	+73 +40	+92 +40	+33 +20	+41 +20	+53 +20	+20 +7	+28 +7	+13 0	+21 0
24	30																
30	40	+270 +170	+182 +120	+220 +120	+119 +80	+142 +80	+180 +80	+75 +50	+89 +50	+112 +50	+41 +25	+50 +25	+64 +25	+25 +9	+34 +9	+16 0	+25 0
40	50	+280 +180	+192 +130	+230 +130													
50	65	+310 +190	+214 +140	+260 +140	+146 +100	+174 +100	+220 +146	+90 +60	+106 +60	+134 +60	+49 +30	+60 +30	+76 +30	+29 +10	+40 +10	+19 0	+30 0
65	80	+320 +200	+224 +150	+270 +150													

Технические данные

▶ Допуск отверстия

Допуск (μm)																	
H8	H9	H10	JS6	JS7	K6	K7	M6	M7	N6	N7	P6	P7	R7	S7	T7	U7	X7
+14 0	+25 0	+40 0	±3	±5	0 -6	0 -10	-2 -8	-2 -12	-4 -10	-4 -14	-6 -12	-6 -16	-10 -20	-14 -24	-	-18 -28	-20 -30
+18 0	+30 0	+48 0	±4	±6	+2 -6	+3 -9	-1 -9	0 -12	-5 -13	-4 -16	-9 -17	-8 -20	-11 -23	-15 -27	-	-19 -31	-24 -36
+22 0	+36 0	+58 0	±4.5	±7.5	+2 -7	+5 -10	-3 -12	0 -15	-7 -16	-4 -19	-12 -21	-9 -24	-13 -28	-17 -32	-	-22 -37	-28 -43
+27 0	+43 0	+70 0	±5.5	±9	+2 -9	+6 -12	-4 -15	0 -18	-9 -20	-5 -23	-15 -26	-11 -29	-16 -34	-21 -39	-	-26 -44	-33 -51 -38 -56
+33 0	+52 0	+84 0	±6.5	±10.5	+2 -11	+6 -15	-4 -17	0 -21	-11 -24	-7 -28	-18 -31	-14 -35	-20 -41	-27 -48	-	-33 -54	-46 -67 -56 -77
+39 0	+62 0	+100 0	±8	±12.5	+3 -13	+7 -18	-4 -20	0 -25	-12 -28	-8 -33	-21 -37	-17 -42	-25 -50	-34 -59	-	-39 -64 -45 -70	-51 -76 -61 -86
+46 0	+74 0	+120 0	±9.5	±15	+4 -15	+9 -21	-5 -24	0 -30	-14 -33	-9 -39	-26 -45	-21 -51	-30 -60 -32 -62	-42 -72 -48 -78	-55 -85 -64 -94	-76 -106 -91 -121	-

► Специальные размеры

	Сквозное <input type="checkbox"/> Глухое <input type="checkbox"/> ØD1 _____ L1 _____ α1 _____ S _____ • Допуск отверстия _____	

	Сквозное <input type="checkbox"/> Глухое <input type="checkbox"/> ØD1 _____ L1 _____ α1 _____ L2 _____ • Допуск отверстия _____	

	Сквозное <input type="checkbox"/> Глухое <input type="checkbox"/> ØD1 _____ L1 _____ α1 _____ L2 _____ S _____ α2 _____ • Допуск отверстия _____	

Комментарии

Тип сверла

- TOPDRILL _____
- T-DRILL _____

Технические данные

- Тип станка
 Обрабатывающий центр Токарный
 Вертикальный Горизонтальный
 Давление СОЖ _____
 Мощность _____ кВт

- Подача СОЖ
 Внутренняя Наружная
 Давление СОЖ _____ бар
 Тип СОЖ _____

Заготовка

- Деталь _____
- Материал _____
- Твердость _____

Тип хвостовика

- Цилиндрический (ISO 9766)
- Хвостовик с лыской
- Цилиндрический с лыской
- Хвостовик Weldon

► Специальные размеры

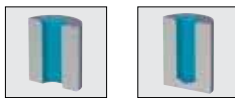
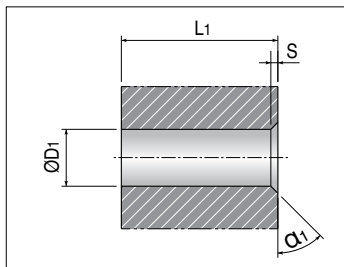

Сквозное Глухое
 ØD1 _____ L1 _____
 α1 _____ S _____
 • Допуск отверстия _____

Технические данные

• Тип станка
 Обрабатываемый центр Токарный
 Вертикальный Горизонтальный
 Давление СОЖ _____
 Мощность _____ кВт

• Подача СОЖ
 Внутренняя Наружная
 Давление СОЖ _____ бар
 Тип СОЖ _____

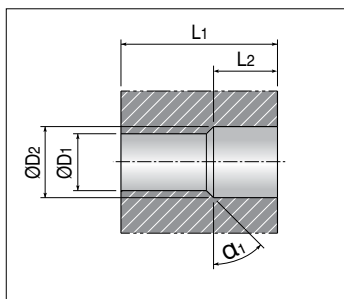

Сквозное Глухое
 ØD1 _____ ØD2 _____
 L1 _____ L2 _____
 α1 _____
 • Допуск отверстия _____

Заготовка

• Деталь _____
 • Материал _____
 • Твердость _____

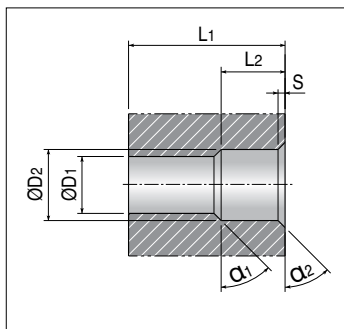

Сквозное Глухое
 ØD1 _____ ØD2 _____
 L1 _____ L2 _____
 α1 _____ α2 _____
 S _____
 • Допуск отверстия _____

Тип хвостовика

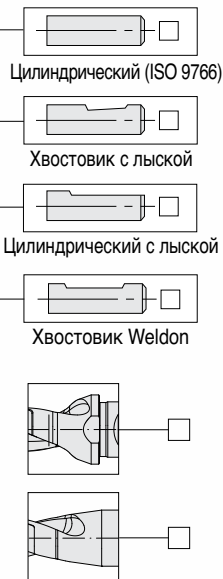

• Диаметр хвостовика: _____
 • Длина хвостовика: _____

Комментарии

► Специальные размеры

• DC, DC_2 диаметры отверстий. Необходимо указать допуск отверстия.

Технические данные

- Тип станка
 - Обработывающий центр Токарный
 - Вертикальный Горизонтальный
- Давление СОЖ _____
- Мощность _____ кВт
- Подача СОЖ
 - Внутренняя Наружная
- Давление СОЖ _____ бар
- Тип СОЖ _____

Заготовка

- Деталь _____
- Материал _____
- Твердость _____

Тип отверстия

- Глухое отверстие
- Сквозное отверстие

Покрытие

- TiAlN
- Без покрытия

Тип хвостовика

- Цилиндрический
- Хвостовик с лыской
- Цилиндрический с лыской
- Хвостовик Weldon

Комментарии

► Бланк заказа инструмента для глубокого сверления

★ : Поля обязательные для заполнения

Название компании :	Номер запроса :
Адрес :	Дата запроса :
Контактное лицо :	Номер клиента :

Заготовка (желательно приложить чертеж)	
Название изделия	
Диаметр отверстия (ø)	(мм)
Глубина отверстия (длина сверления)	(мм)
Количество отверстий	
Допуск отверстия	
Шероховатость поверхности (Rz, Ra...)	
Отклонение (мм/100)	
Прямолинейность (мм/100)	
Материал	
Материал (DIN, AISI, JIS...)	
Твердость (HB, HS, HRC...)	
Состояние ★	<input type="checkbox"/> Отожженный <input type="checkbox"/> Закаленный <input type="checkbox"/> Отпущенный <input type="checkbox"/> Литье <input type="checkbox"/> <input type="checkbox"/> Другое <input type="checkbox"/>

Станок	
Производитель	
Тип/модель станка	
Жесткость	<input type="checkbox"/> Хорошая <input type="checkbox"/> Удовлетворительная <input type="checkbox"/> Плохая
Дата производства	
Модернизация	<input type="checkbox"/> Инструмент и заготовка <input type="checkbox"/> М/ОЦ <input type="checkbox"/> Другое
Двойное вращение (инструмента и заготовки)	<input type="checkbox"/> Инструмент и заготовка
Вращение заготовки (WR)	<input type="checkbox"/>
Вращение заготовки (TR)	<input type="checkbox"/>
Защитное устройство	
Мощность двигателя	(кВт)

Тип СОЖ	
Производитель СОЖ	
На водной основе	<input type="checkbox"/> Растворимая <input type="checkbox"/> Эмульсия %
На масляной основе	<input type="checkbox"/>
Давление СОЖ	(бар)
Расход СОЖ	(л/мин)

► Бланк заказа инструмента для глубокого сверления

*: Поля обязательные для заполнения

Сверлильная головка			
Сверлильная головка(ø)	(мм)		
Резьба	<input type="checkbox"/> Внутренняя	<input type="checkbox"/> Наружная	
Напайная	<input type="checkbox"/>		
Со сменными пластинами	<input type="checkbox"/> Настраиваемая	<input type="checkbox"/> Нерегулируемая	<input type="checkbox"/>
Покрытие	<input type="checkbox"/> С покрытием	<input type="checkbox"/> Без покрытия	
Тип покрытия	<input type="checkbox"/> TiN	<input type="checkbox"/> TiAlN	<input type="checkbox"/> Другое
• Сверление	<input type="checkbox"/>		
• Растачивание	<input type="checkbox"/>		
Угол резания*	<input type="checkbox"/> 20°	<input type="checkbox"/> 45°	
Напайные, с пластинами	<input type="checkbox"/> Нормальный угол	<input type="checkbox"/> Острый угол	
Предварительный размер (на сторону)	(мм)		
Форма дна*	<input type="checkbox"/> С полным радиусом	<input type="checkbox"/> Плоское дно	<input type="checkbox"/> С углом при вершине
	<input type="checkbox"/> Сложный профиль		
• Кольцевое сверление	<input type="checkbox"/>		
Диаметр стержня(ø)	(мм)		<input type="checkbox"/>
Внутренний диаметр трубы(ø)	(мм)		
Наружный диаметр трубы(ø)	(мм)		
Труба			
Наружный диаметр(ø)	(мм)		
Общая длина(L)	(мм)		
Внутренняя резьба	<input type="checkbox"/>		
Наружная резьба	<input type="checkbox"/> 4-заходная	<input type="checkbox"/> 2-заходная	<input type="checkbox"/> 1-заходная
Резьба на трубе	<input type="checkbox"/> С одной стороны	<input type="checkbox"/> С двух сторон	
Длина втнутренней трубы	(мм)		
Паз на внутренней трубе	<input type="checkbox"/> с одной стороны	<input type="checkbox"/> С двух сторон	
Система сверления			
Однотрубная	<input type="checkbox"/>	STS	
Двухтрубная	<input type="checkbox"/>	DTS	
Условия обработки			
Сверление сквозных отверстий	<input type="checkbox"/>		
Сверление глухих отверстий	<input type="checkbox"/>		
Сверление пересеченных отверстий*	<input type="checkbox"/>		

* Эскиз схемы сверления

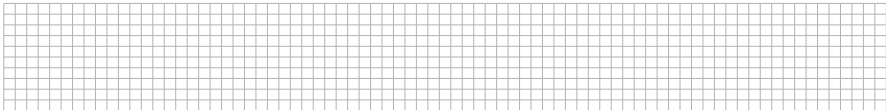

Общая информация	Производство		
Количество в год:			
Состояние в настоящее время:			
Сплав, стойкость и т.д.:			
Режимы резания:	Vc=	м/мин,	N= об/мин
	f=	мм/об,	F= мм/мин

► Бланк заказа инструмента для глубокого сверления

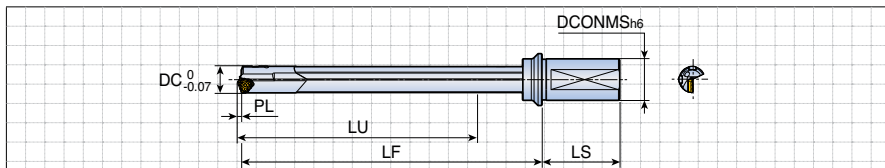

Эскиз схемы сверления

• Примечание: возможно потребуется изменить некоторые параметры на основании нашего опыта в данной операции

Инструмент	
Количество	
Номинальный диаметр и допуск	
- Укажите размеры на эскизе	
Хвостовик	
Код хвостовика	

- Для стандартных хвостовиков используйте коды на стр. 244-245, для специальных - приложите эскиз и параметры хвостовика

Заготовка (Приложите чертеж, если возможно)	
Обозначение материала (Обозначение по DIN или другому стандарту)	
Твердость и свойства	<input type="checkbox"/> Глухое отверстие <input type="checkbox"/> Сквозное отверстие <input type="checkbox"/> Рассверливание
Тип отверстия	<input type="checkbox"/> Врезание в наклонную поверхность <input type="checkbox"/> Сверление в сплошном металле <input type="checkbox"/> Растачивание <input type="checkbox"/> Вывод сверла из наклонной поверхности
Глубина сверления	мм
Допуск отверстия	
Применение	Заготовка <input type="checkbox"/> Неподвижна <input type="checkbox"/> Вращается
	Инструмент <input type="checkbox"/> Неподвижна <input type="checkbox"/> Вращается

Станок					
Тип станка					
Мощность		кВт			
Режимы резания	Скорость резания (Vc)	м/мин			
	Обороты	Nmin :	RPM	Nmax :	RPM
	Подача	Fmin :	мм/об	Fmin :	мм/об
	Скорость подачи (VF)	мм/мин			
СОЖ	Тип СОЖ	<input type="checkbox"/> Масло	<input type="checkbox"/> Эмульсия	<input type="checkbox"/> Другое	
	Давление СОЖ	бар			
	Расход СОЖ	л/мин			

► Стандартные хвостовики ружейных сверл для обрабатывающих центров и токарных станков

Хвостовики

Хвостовики применимы на станках с ЧПУ и специальном оборудовании, а также доступны в различных диаметрах и длинах. Коды хвостовиков и технические характеристики указаны в таблице ниже

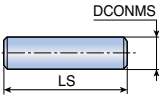
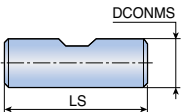
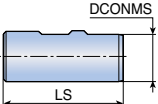
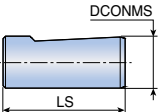
Тип хвостовика	Эскиз	DCONMS x LS	Код хвостовика
Цилиндрический DIN1835A DIN6535HA		20x50	10
		25x56	11
		32x60	12
		40x70	13
		.75x2.03"	95
		1.00x2.28"	96
		1.25x2.28"	97
Велдон DIN1835B DIN6535HB	 	20x50	22
		25x56	23
		32x60	24
		40x70	25
		.75x2.03"	99
Хвостовик с лыской DIN1835E		20x50	34
		25x56	35
		32x60	36
		40x70	37

► Стандартные хвостовики для станков для глубокого сверления

Тип хвостовика	Эскиз	DCONMS x LS	Код хвостовика
DIN228AK		CM2	46
		CM3	47
		CM4	48
DIN228BK		CM2	50
		CM3	51
		CM4	52
Центральный зажим под углом 15°		.750x2.75"	56
		25x70	57
		1.00x2.75"	58
		1.25x2.75"	59
		1.50x2.75"	60
Передний зажим под углом 15°		16x50	61
Цилиндрический с резьбой		25x100 M16x1.5	66
		36x120 M24x1.5	67
Тип VDI		25x112 M16x1.5	70
		36x135 M24x1.5	71
Центральный зажим шестиугольный		25x70	72
		32x70	73
Центральный зажим конический		.75x2.75"	76
		20x70	77
Передний зажим под углом 2°		1.00x2.75"	80
		1.00x3.94"	81
		1.25x2.75"	82
		1.25x3.94"	83
		1.50x2.75"	84
		1.50x3.94"	85
С трапецидальной резьбой		28x126 Tr 28x2	88
		36x162 Tr 36x2	89
Хвостовик-распылитель		25x50	91
		35x60	92

► Бланк заказа развертки

*: Поля обязательные для заполнения

Дата : _____ Дистрибьютор: _____

Компания * : _____ Крайний срок исполнения: _____







Контактное лицо: _____

Адрес: _____

Причина запроса	
Новый инструмент <input type="checkbox"/>	Проблема <input type="checkbox"/>
Качество	
Время цикла	
Конкурент	
Другое	

Существующий инструмент	
Производитель	
Тип	
Скорость и подача	
Стойкость	
Количество зубьев	
СОЖ	

Станок	
Модель	
Тип *	Вертикальный <input type="checkbox"/>
	Горизонтальный <input type="checkbox"/>
	Многошпиндельный <input type="checkbox"/>
Оснастка *	
Максимальные обороты	
Мощность	
Точность шпинделя	
СОЖ	

Заготовка	
Обозначение *	
Твердость *	
Диаметр предварительного отверстия *	(Допуск : _____)
Глубина *	
Тип отверстия	
<input type="checkbox"/>  <input type="checkbox"/>  <input type="checkbox"/>  <input type="checkbox"/>  <input type="checkbox"/> 	
<input type="checkbox"/>  <input type="checkbox"/>  <input type="checkbox"/>  <input type="checkbox"/> 	
Способ закрепления	

СОЖ	
Масло	<input type="checkbox"/>
Минимальное количество СОЖ	<input type="checkbox"/>
Эмульсия	<input type="checkbox"/>
Состав смеси	
Давление СОЖ	

Требования к отверстию	
Допуск *	
Шероховатость поверхности (Ra) *	
Округленность	
Прямолинейность	
Цилиндричность	
Соосность	

Инструмент	
Тип *	ТМ(со сменной головкой) <input type="checkbox"/> ТВ(с лезвием) <input type="checkbox"/> ТS(монолитная) <input type="checkbox"/> Другое <input type="checkbox"/> (_____)
Диаметр *	
Диаметр резания *	
Подача СОЖ *	Внутренняя <input type="checkbox"/> Наружная <input type="checkbox"/>
Тип хвостовика *	
Патрон	Цанговый <input type="checkbox"/> Гидравлический <input type="checkbox"/> Другое <input type="checkbox"/>
Регулируемый адаптер	Да <input type="checkbox"/> Нет <input type="checkbox"/>