

0
1155 -2

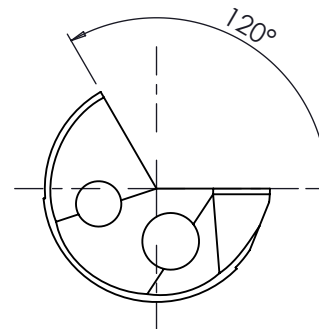
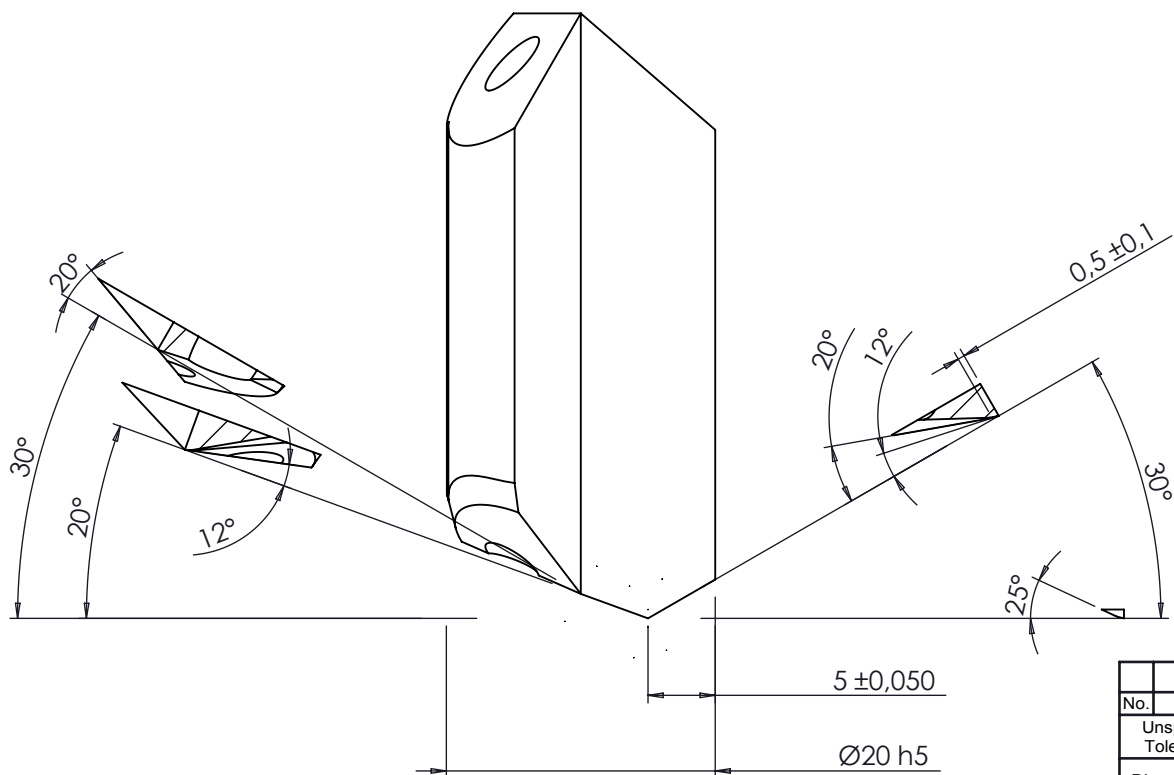
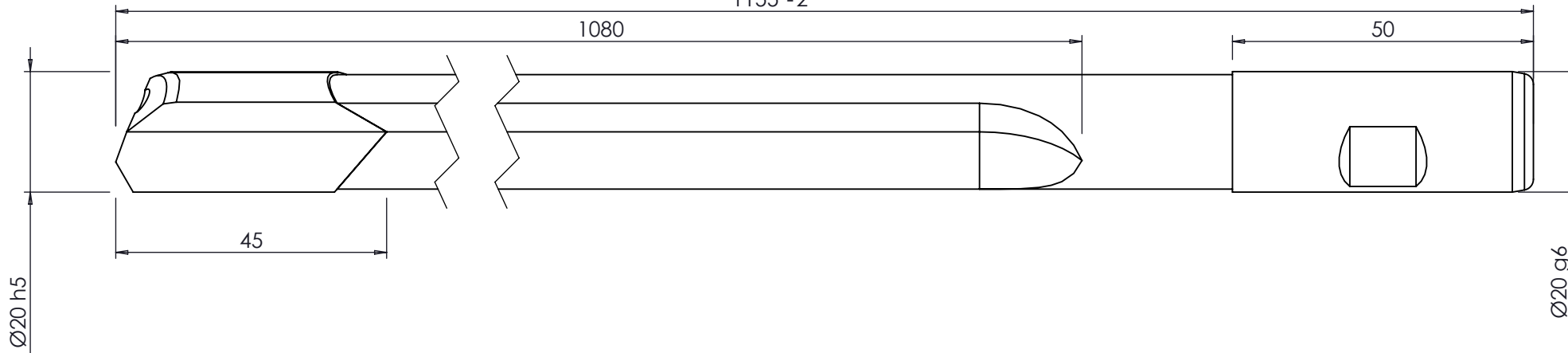

Pad Form : G
Coating : Uncoated
Back Taper : Standard
Carbide Grade : K15-K20

No.	Item / Designation	Qty	Dwg / Cat. no.	Material	Dimensions	Notes
Unspecified Tolerances	Name	Date	Customer : TAEGUTEK RUSSIA			
Draw	J.WALT	03/02/2010	Designation : STGD-20000-1155-22-IC08			
Design	J.WALT	03/02/2010	Description : Standard Gundrill			
Check	B.DEBETHUNE	03/02/2010	Gundrill Ø20X1155			
Appr.	B.DEBETHUNE	03/02/2010				
Angles : ± 30'			Scale : SCALE		Item No :	
Copyright © this Drawing & Design is Confidential Property of OUTILTEC Soufflenheim No part of it may be reproduced or conveyed otherwise without documented consent of OUTILTEC Soufflenheim						Drawing No. 14302920-F3 Sheet No : 1/1 Rev. No. 0 P.O. No :

Rev. No.	Alteration	Date	Name